

SMB Storage Platform with FalconStor Software

Overview

Storage is a key requirement in today's small-to-medium business (SMB) and small office/home office (SOHO) markets, as the need to backup and recover critical data has become increasingly important. Smaller businesses also require many of the features that are common in the enterprise segment, such as RAID protection and recovery operations available through networked attached storage (NAS) devices.

The SMB storage platform allows original design manufacturers (ODMs) and original equipment manufacturers (OEMs) to develop cost-effective NAS storage solutions with minimal time to market. This platform is based on the MPC8349E PowerQUICC™ II Pro processor and FalconStor® Software's IPStor® Express software.

The MPC8349E is a highly integrated processing solution that enables next-generation storage solutions. The MPC8349E processor integrates the enhanced e300 core, built on Power Architecture™ technology, and advanced features such as DDR memory, dual PCI, Gigabit Ethernet and high-speed USB controllers. The processor supports dual 10/100/1000 Mbps Ethernet controllers, dual 32-bit/single 64-bit PCI controllers, integrated security engines, USB 2.0 host and device controllers, 4-channel DMA, DUART, serial peripherals, general purpose I/O and system timers. The high level of integration in the MPC8349E helps to lower system costs, improve performance and simplify board design.

SMB Storage Network

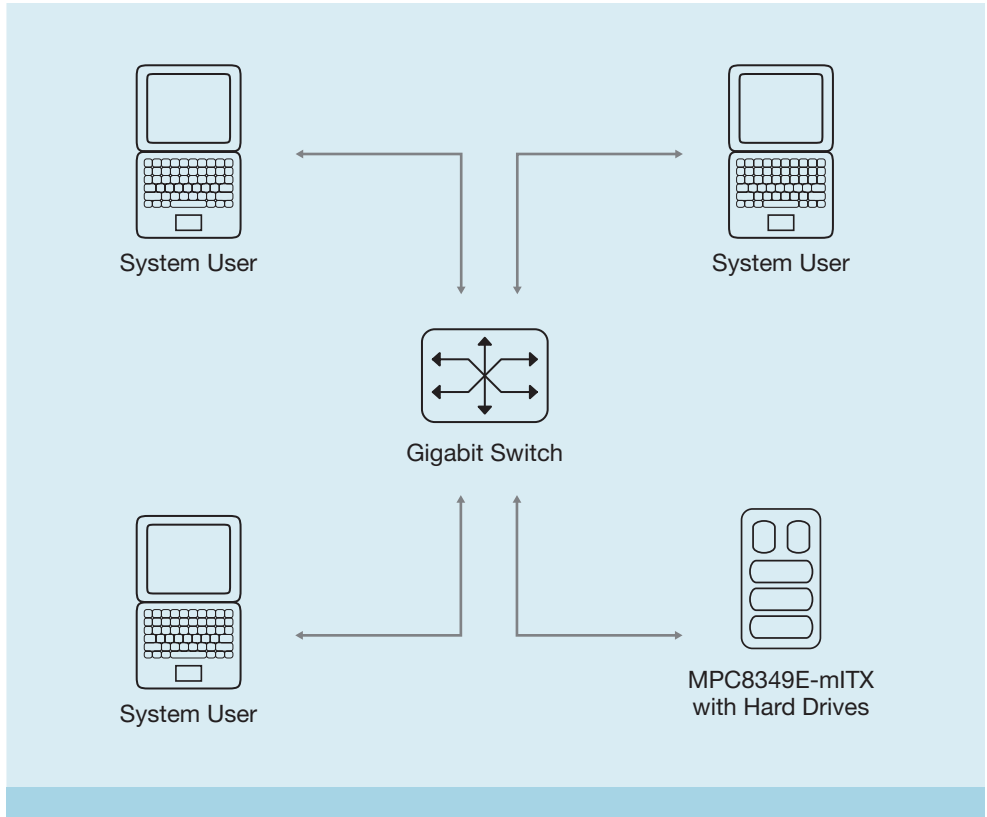

In addition to the highly integrated MPC8349E processor, the reference platform supports the storage market with these additional features:

- Four Serial ATA ports
- Four high-speed USB ports
- Five-port Gigabit Ethernet switch for LAN, plus one Ethernet WAN port
- PCI slot, MiniPCI slot and compact flash memory slot

FalconStor's IPStor Express Software

The SMB Storage platform allows businesses to store, backup and recover critical data using the MPC8349E-mITX reference platform with software from FalconStor, a leader in enterprise software solutions. FalconStor's IPStor Express software, designed specifically for the SMB and SOHO market, enables users to easily protect and manage their information with a powerful software storage solution.

IPStor Express Key Features

- Embedded RAID functions
- Bare metal recovery
- File and print sharing
- Block-level data protection (DiskSafe™ Agent)
- File-level data protection (FileSafe™ Agent)
- Disk-based snap shot agents (expandable)
- Easy to use Web-based interface
- Linux® based
- Supports NAS (CIFS/NFS) and SAN (iSCSI)

For more information, visit www.falconstor.com.

MPC8349E-mITX Block Diagram

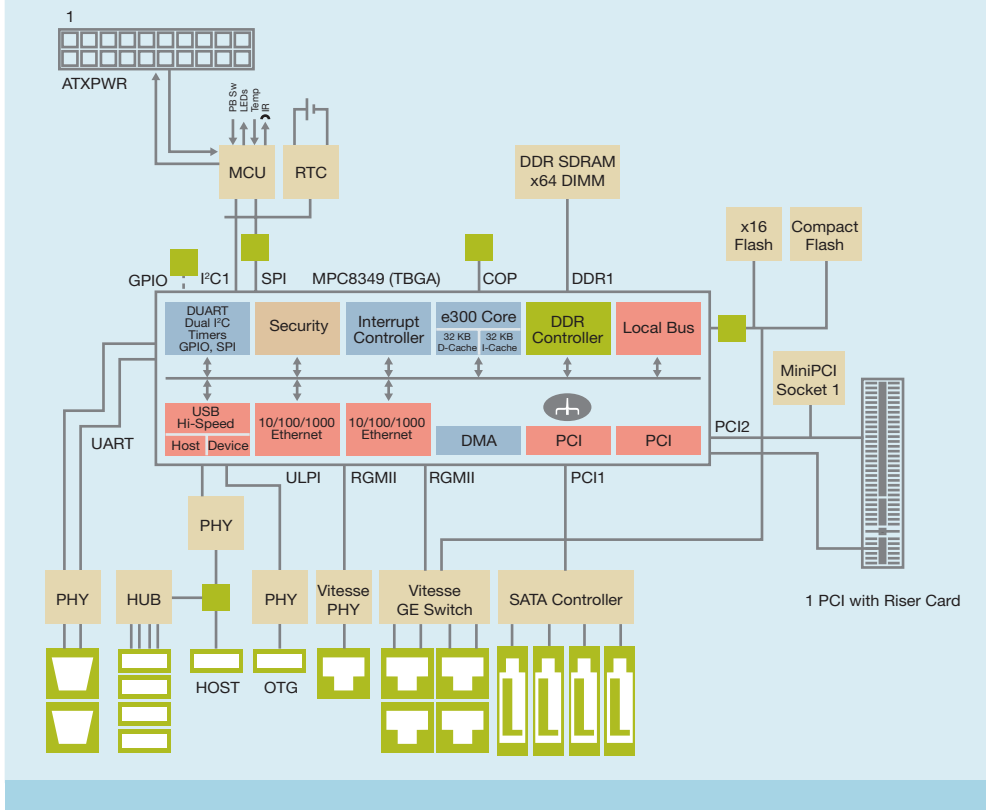

Learn More: For current information about Freescale products and documentation, please visit www.freescale.com.



Freescale™ and the Freescale logo are trademarks of Freescale Semiconductor, Inc. All other product or service names are the property of their respective owners. The Power Architecture and Power.org word marks and the Power and Power.org logos and related marks are trademarks and service marks licensed by Power.org.
© Freescale Semiconductor, Inc. 2007

Document Number: FALCONSTORFS
REV 1

