



# Galvanically-Isolated High-Speed CAN Transceiver

## TJA1052IT

Last Updated: Apr 20, 2023

The TJA1052i is a high-speed CAN transceiver that provides a galvanically isolated interface between a Controller Area Network (CAN) protocol controller and the physical two-wire CAN bus. The TJA1052i is specifically targeted at Electric Vehicles (EV) and Hybrid Electric Vehicles (HEV), where galvanic isolation barriers are needed between the high- and low-voltage parts.

**Safety:** Isolation is required for safety reasons, eg. to protect humans from electric shock or to prevent the electronics being damaged by high voltages.

**Signal integrity:** The isolator uses proprietary capacitive isolation technology to transmit and receive CAN signals. This technology enables more reliable data communications in noisy environments, such as high-voltage battery management systems or the drive and regeneration systems in EVs and HEVs.

**Performance:** The transceiver is designed for high-speed CAN applications in the automotive industry, supplying the differential transmit and receive capability to a CAN protocol controller in a microcontroller. Integrating the galvanic isolation along with the transceiver in the TJA1052i removes the need for stand-alone isolation. It also improves reliability and system performance parameters such as loop delay.

The TJA1052i belongs to the third generation of high-speed CAN transceivers from NXP Semiconductors, offering significant improvements over first- and second-generation devices. It offers improved ElectroMagnetic Compatibility (EMC) and ElectroStatic Discharge (ESD) performance, and also features ideal passive behavior to the CAN bus when the transceiver supply voltage is off.

The TJA1052i implements the CAN physical layer as defined in the current ISO11898 standard (ISO11898-2:2003). Pending the release of ISO11898-2:2016 including CAN FD and SAE

J2284-4/5, additional timing parameters defining loop delay symmetry are specified. This implementation enables reliable communication in the CAN FD fast phase at data rates up to 5 Mbit/s.

The TJA1052i is an excellent choice for all types of automotive and industrial CAN networks where isolation is required for safety reasons or to enhance signal integrity in noisy environments.

### TJA1052IT Block Diagram Block Diagram

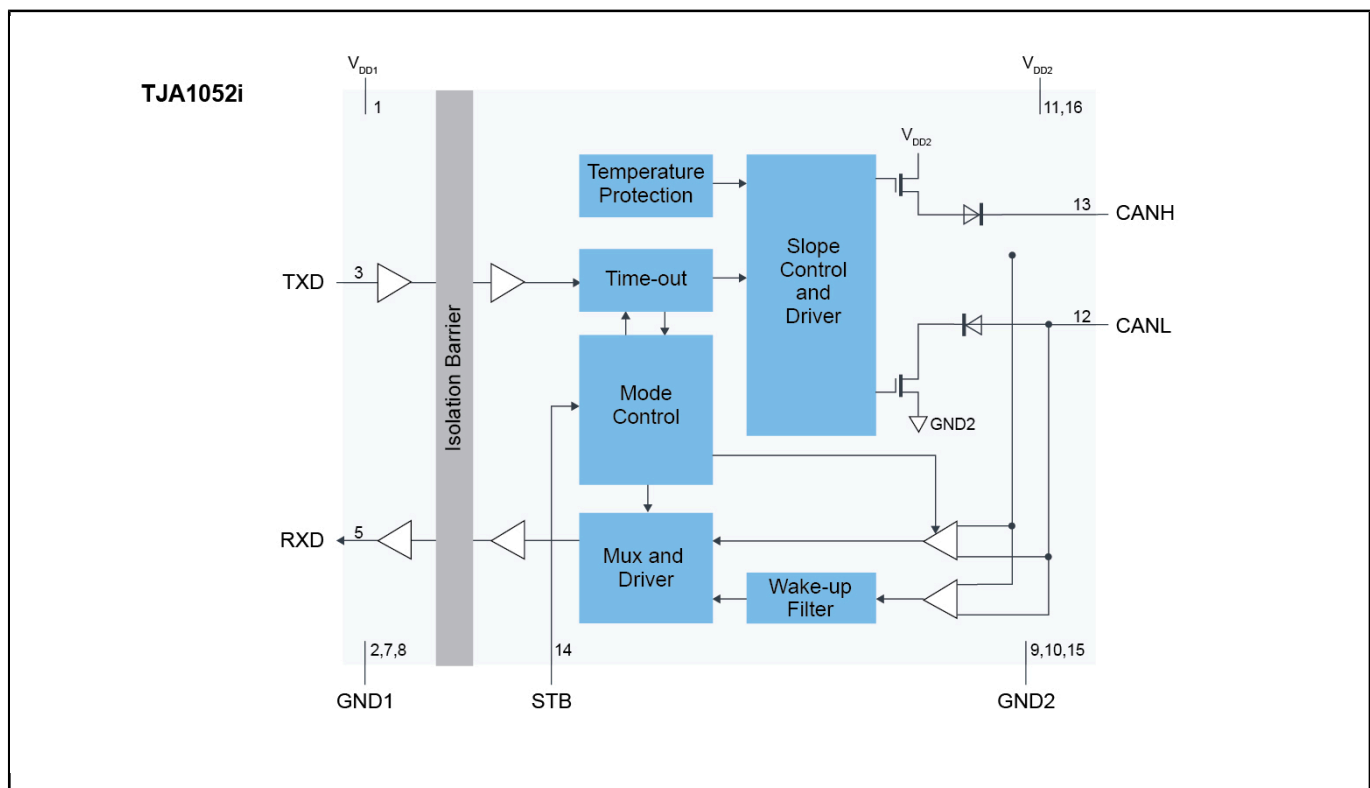

View additional information for [Galvanically-Isolated High-Speed CAN Transceiver](#).

**Note:** The information on this document is subject to change without notice.

**www.nxp.com**

NXP and the NXP logo are trademarks of NXP B.V. All other product or service names are the property of their respective owners. The related technology may be protected by any or all of patents, copyrights, designs and trade secrets. All rights reserved. © 2024 NXP B.V.