



# Permanent Magnet Synchronous Motor (PMSM)

Last Updated: Jul 13, 2023

Permanent magnet synchronous motors (PMSM) are typically used for high-performance and high-efficiency motor drives. High-performance motor control is characterized by smooth and accurate rotation over the entire speed range of the motor. NXP provides a comprehensive development ecosystem to support a rapid design of motor control devices that integrates PMSM.

## 3 Phase PMSM Block Diagram

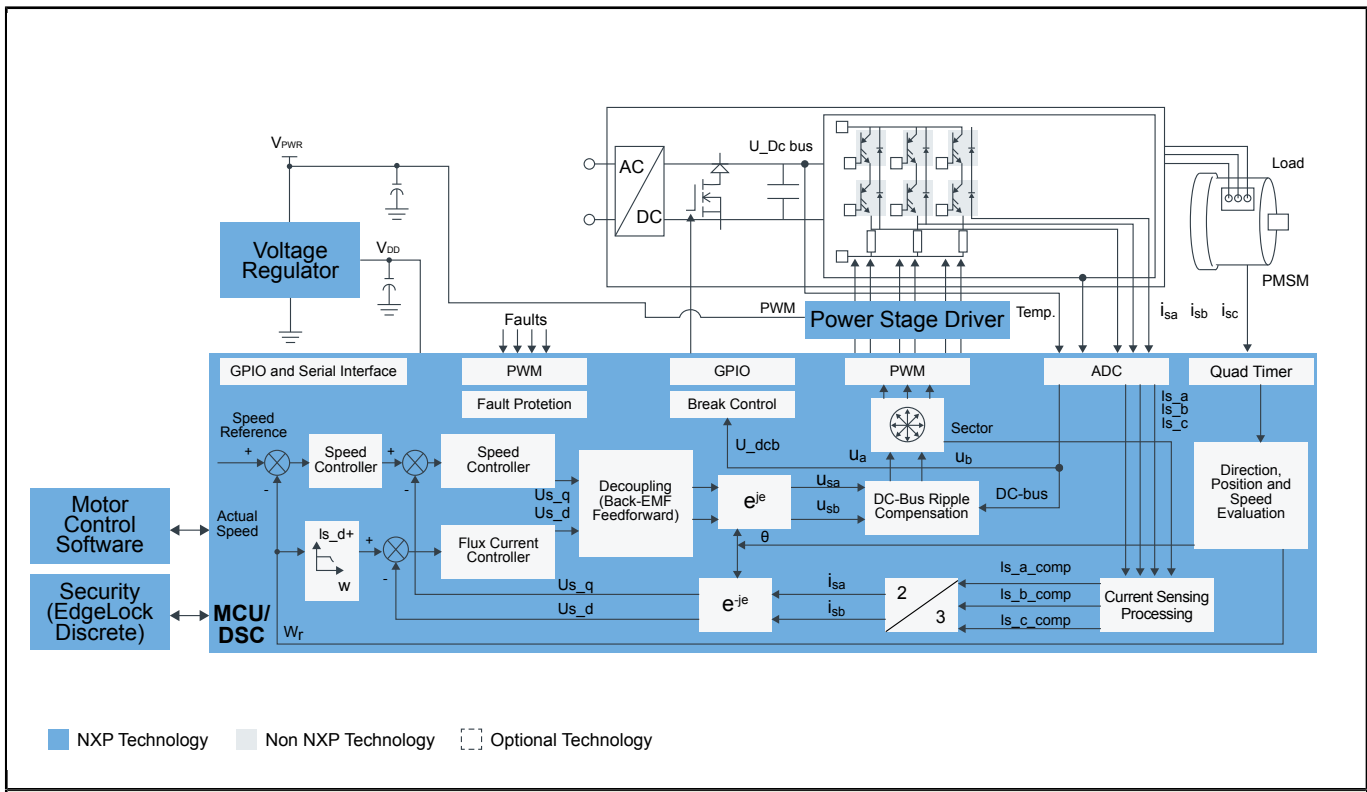

### Recommended Products for 3 Phase PMSM

MCU	<ul style="list-style-type: none"> <li>• <b>MCX-A14X-A15X:</b> MCX A14x/15x MCUs with Arm® Cortex® M33, Scalable Device Options, Low Power and Intelligent Peripherals</li> </ul>
-----	---

	<ul style="list-style-type: none"> <li>• <a href="#">MCX-N94X-N54X</a>: MCX N94x/54x Highly Integrated Multicore MCUs with On-Chip Accelerators, Intelligent Peripherals and Advanced Security</li> <li>• <a href="#">S32M2</a>: S32M2 Integrated Solution for 12V Motor Control</li> <li>• <a href="#">S32K3</a>: S32K3 Microcontrollers for Automotive General Purpose</li> <li>• <a href="#">KV Series Arm Cortex-M4/M0+/M7</a>: KV Series: Real-Time Motor Control and Power Conversion MCUs Based on Arm® Cortex®-M0+/M4/M7</li> <li>• <a href="#">KE Series Arm Cortex-M4/M0+</a>: Kinetis® E Series: 5V, Robust Microcontrollers (MCUs) Based on Arm® Cortex®-M0+/M4 Core</li> <li>• <a href="#">S32K1</a>: S32K1 Microcontrollers for Automotive General Purpose</li> </ul>
Power stage driver	<ul style="list-style-type: none"> <li>• <a href="#">MC33937</a>: 3-Phase Field Effect Transistor Pre-Driver</li> <li>• <a href="#">GD3100</a>: Advanced High Voltage Isolated Gate Driver for IGBT and SiC MOSFETs</li> </ul>
Motor Control Software	<ul style="list-style-type: none"> <li>• <a href="#">FreeMASTER Run-Time Debugging Tool</a></li> <li>• <a href="#">RTCESL</a>: Real Time Control Embedded Software Motor Control and Power Conversion Libraries</li> <li>• <a href="#">Model-Based Design Toolbox (MBDT)</a></li> <li>• <a href="#">Motor Control Application Tuning (MCAT) Tool</a></li> </ul>
Voltage regulator	<ul style="list-style-type: none"> <li>• <a href="#">PCA9410_9410A</a>: 3.0 MHz, 500 MA, DC-to-DC Boost Converter</li> <li>• <a href="#">MC33903</a>: SBC Gen2 with High-Speed CAN and LIN</li> <li>• <a href="#">MC33904</a>: System Basis Chip Gen2 with High Speed CAN</li> <li>• <a href="#">MC33905</a>: SBC Gen2 with High-Speed CAN and LIN</li> </ul>
Security (EdgeLock Discrete)	<ul style="list-style-type: none"> <li>• <a href="#">SE050</a>: EdgeLock® SE050: Plug and Trust Secure Element Family – Enhanced IoT security with high flexibility</li> </ul>
Security (EdgeLock Discrete)	<ul style="list-style-type: none"> <li>• <a href="#">SE050</a>: EdgeLock® SE050: Plug and Trust Secure Element Family – Enhanced IoT security with high flexibility</li> </ul>

View our complete solution for [Permanent Magnet Synchronous Motor \(PMSM\)](#).

**Note:** The information on this document is subject to change without notice.

**[www.nxp.com](http://www.nxp.com)**

NXP and the NXP logo are trademarks of NXP B.V. All other product or service names are the property of their respective owners. The related technology may be protected by any or all of patents, copyrights, designs and trade secrets. All rights reserved. © 2024 NXP B.V.