



Two-Channel I²C-Bus Multiplexer

PCA9540B

Last Updated: Oct 25, 2023

The PCA9540B is a 1-of-2 bidirectional translating multiplexer, controlled via the I²C-bus. The SCL/SDA upstream pair fans out to two SCx/SDx downstream pairs, or channels. Only one SCx/SDx channel is selected at a time, determined by the contents of the programmable control register.

A power-on reset function puts the registers in their default state and initializes the I²C-bus state machine with no channels selected.

The pass gates of the multiplexer are constructed such that the VDD pin can be used to limit the maximum high voltage that is passed by the PCA9540B. This allows the use of different bus voltages on each SCx/SDx pair, so that 1.8 V, 2.5 V or 3.3 V parts can communicate with 5 V parts without any additional protection. External pull-up resistors can pull the bus up to the desired voltage level for this channel. All I/O pins are 5 V tolerant.

PCA9540B Block Diagram

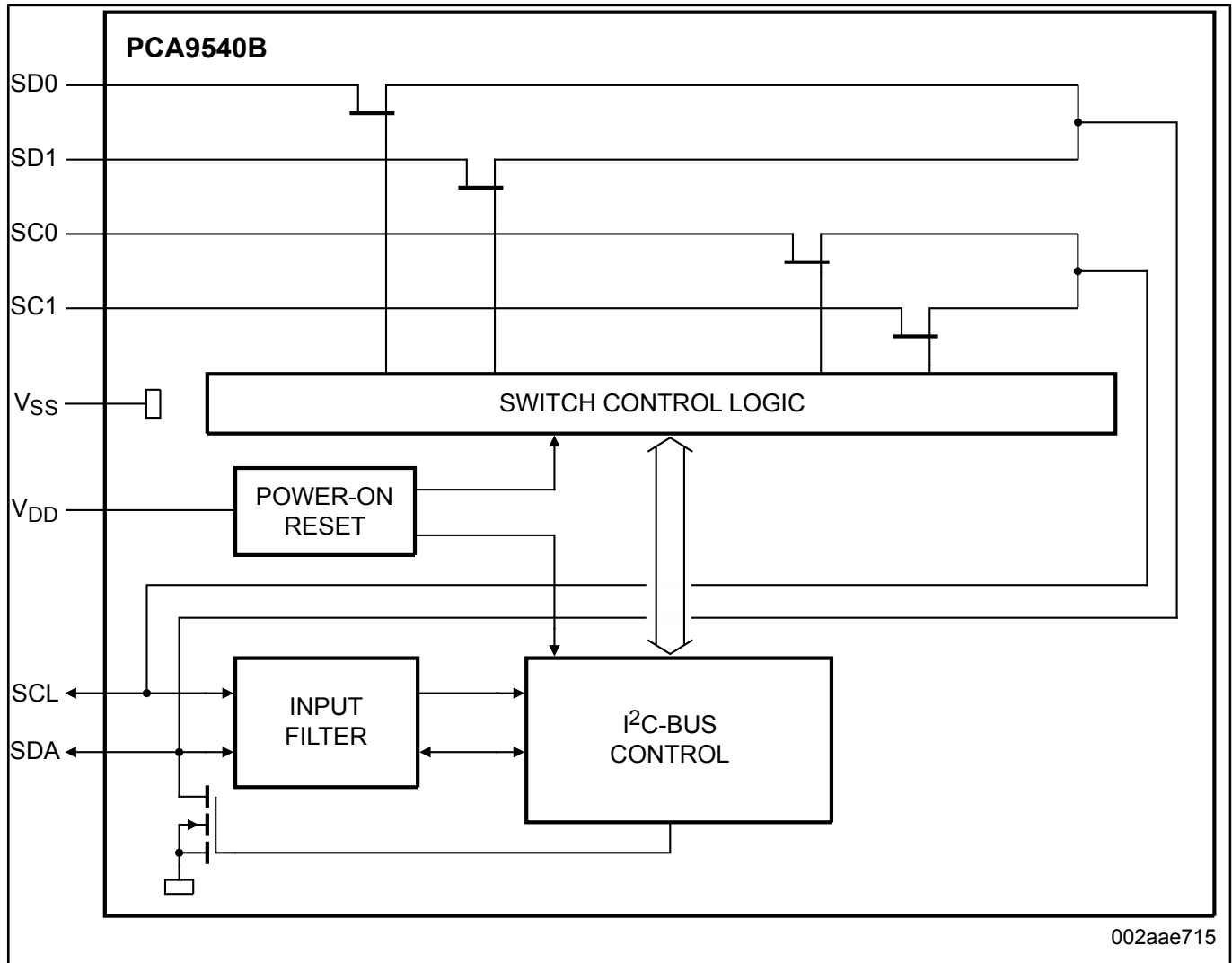

View additional information for [Two-Channel I²C-Bus Multiplexer](#).

Note: The information on this document is subject to change without notice.

www.nxp.com

NXP and the NXP logo are trademarks of NXP B.V. All other product or service names are the property of their respective owners. The related technology may be protected by any or all of patents, copyrights, designs and trade secrets. All rights reserved. © 2024 NXP B.V.