



Bidirectional High-Side Power Switch for Charger and USB#OTG Combined Applications

NX5P3001UK

Last Updated: Mar 18, 2024

The NX5P3001 is an advanced bidirectional power switch and ESD-protection device for combined USB#OTG and charger port applications. It includes undervoltage lockout, overvoltage lockout and overtemperature protection circuits designed to automatically isolate the power switch terminals when a fault condition occurs.

The device features two power switch input/output terminals (VBUSI and VBUSO), an open-drain acknowledge output (ACK), an enable input which includes logic level translation (EN) and low capacitance Transient Voltage Suppression (TVS) type ESD#clamps for USB data and ID pins.

When EN is set HIGH the device enters a low-power mode, disabling all protection circuits. When used in combined charger and USB#OTG applications the 30 V tolerant VBUSI switch terminal is used as the supply and switch input when charging, for USB#OTG the VBUSO switch terminal is used as the supply and switch input.

Designed for operation from 3.2 V to 6.35 V, it is used in battery charging and power domain isolation applications to reduce power dissipation and extend battery life.

NX5P3001UK Block Diagram Block Diagram

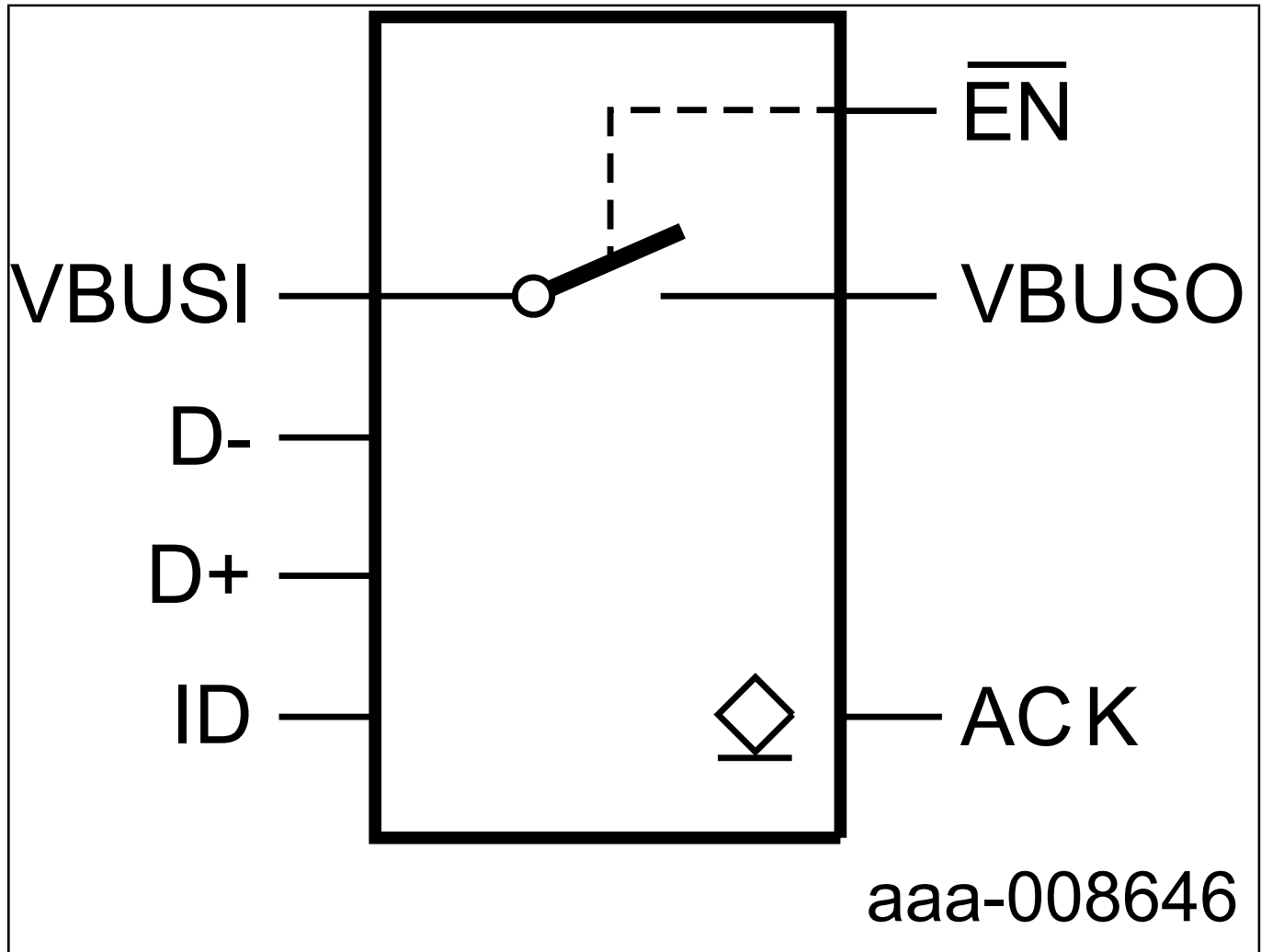

View additional information for [Bidirectional High-Side Power Switch for Charger and USB#OTG Combined Applications](#).

Note: The information on this document is subject to change without notice.

www.nxp.com

NXP and the NXP logo are trademarks of NXP B.V. All other product or service names are the property of their respective owners. The related technology may be protected by any or all of patents, copyrights, designs and trade secrets. All rights reserved. © 2024 NXP B.V.