



Layerscape LS1012A Reference Design Board

LS1012A-RDB

Last Updated: Sep 20, 2023

The LS1012A reference design board (LS1012A-RDB) is a compact form-factor tool for evaluating and developing LS1012A-based application solutions. The Layerscape [LS1012A](#) processor delivers enterprise-class performance and security capabilities to consumer and networking applications in a package size normally associated with microcontrollers. Combining a 64-bit Arm®v8-based processor with network packet acceleration and Layerscape trust architecture security capabilities, the [LS1012A](#) features line-rate networking performance at 1W typical power in a 9.6mm x 9.6mm package.

The LS1012A-RDB provides an Arduino® shield expansion connector for easy prototyping of additional components such as an NXP NFC Reader module. The LS1012A-RDB comes in a compact 5.59 in x 5.59 in a form factor that allows mounting in an enclosure. An SDIO Wi-Fi® module is mounted on the board to facilitate evaluation and development of Wi-Fi connectivity solutions.

Layerscape LS1012A Block Diagram

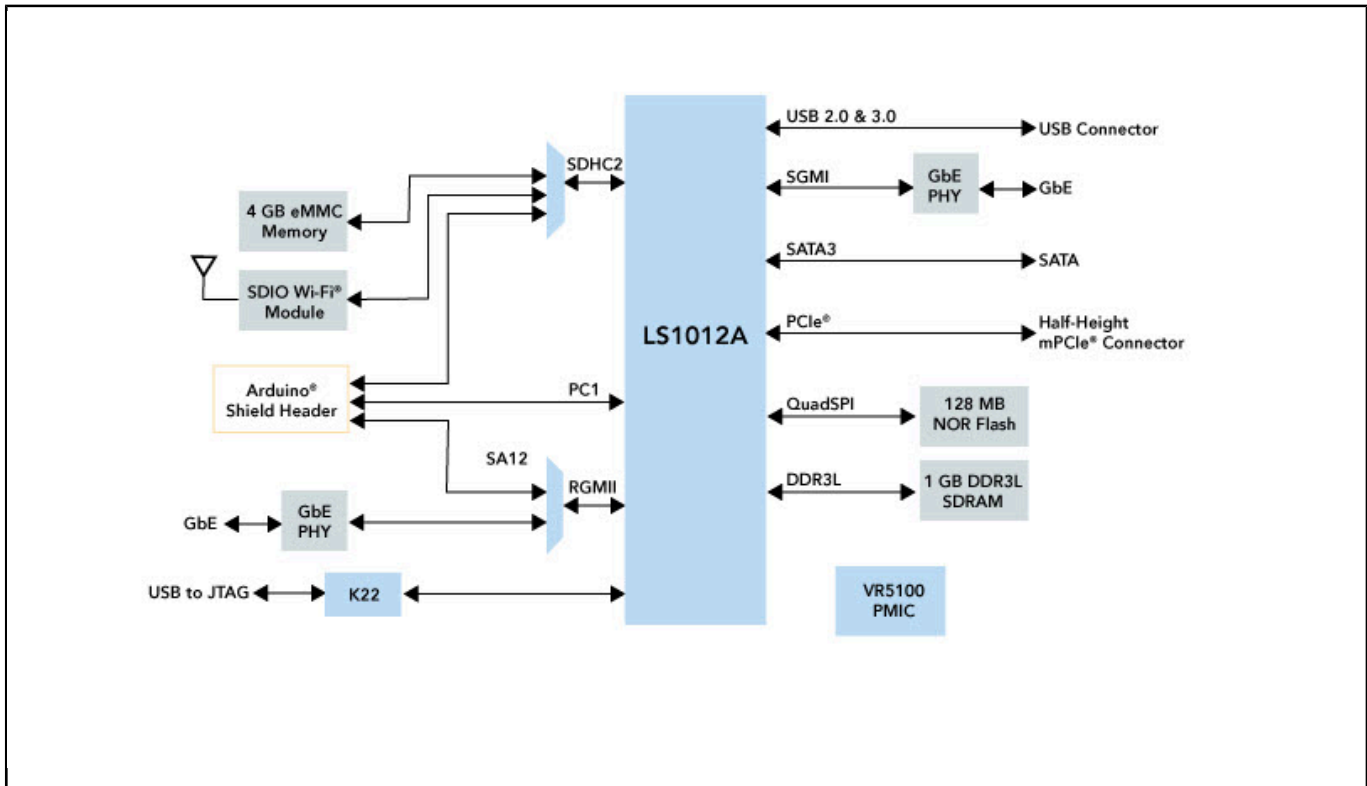

View additional information for [Layerscape LS1012A Reference Design Board](#).

Note: The information on this document is subject to change without notice.

www.nxp.com

NXP and the NXP logo are trademarks of NXP B.V. All other product or service names are the property of their respective owners. The related technology may be protected by any or all of patents, copyrights, designs and trade secrets. All rights reserved. © 2024 NXP B.V.