



Automotive Zone Controller

Last Updated: May 13, 2024

Zonal architectures enable efficient power and data distribution around the vehicle, while improving wire cost, weight, and manufacturing. A key component in this architecture is the zone controller, it is responsible for connecting the high number of actuators and sensors to a central compute ECU and, depending on application distribution, can have a significant role in strategy within a zone.

OEMs are looking for more scalable and cost-efficient solutions to evolve the E/E architecture and meet future requirements for connected, electric, self-driving vehicles, as the number of services/ECUs within the vehicle grows. This evolution can come via logical distribution of functions onto less diverse software/hardware platforms, and through physical changes to a zonal-based network.

Zonal Architecture Block Diagram

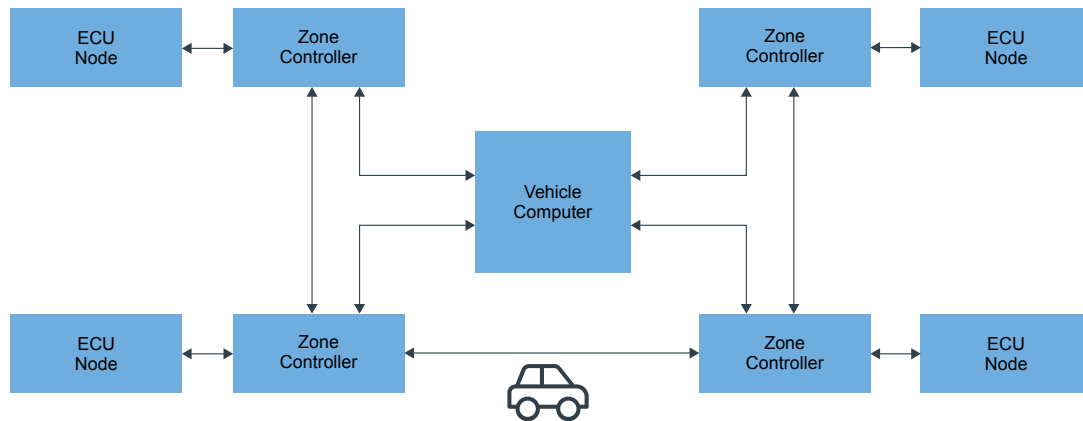

NXP Technology
 Non NXP Technology
 Optional Technology

Recommended Products for Zonal Architecture

Vehicle Computer	<ul style="list-style-type: none"> • S32G3 Vehicle Networking Reference Design • S32G3: S32G3 Processors for Vehicle Networking • SJA1110: Multi-Gig Safe and Secure TSN Ethernet Switch with Integrated 100BASE-T1 PHYs • TJA1120: TJA1120, ASIL B Compliant Automotive Ethernet 1000BASE-T1 PHY Transceiver • TJA1104: TJA1104, MACsec Enabled ASIL B Compliant Automotive Ethernet 100BASE-T1 PHY Transceiver • VR5510: Multi-Channel (9) PMIC for S32G Processor – 8 High Power, 1 Low Power, Fit for ASIL D Safety Level • PF53: 12 A / 8 A / 15 A Core Supply Regulator with AVP and Watchdog
Microcontrollers (MCU)	<ul style="list-style-type: none"> • S32K3: S32K3 Microcontrollers for Automotive General Purpose
Zone Controller	<ul style="list-style-type: none"> • S32K3: S32K3 Microcontrollers for Automotive General Purpose • S32Z2: S32Z2 Safe and Secure High-Performance Real-Time Processors • S32E2: S32E2 Safe and Secure High-Performance Real-Time Processors with Actuation Support

	<ul style="list-style-type: none"> • S32G3: S32G3 Processors for Vehicle Networking • S32G2: S32G2 Processors for Vehicle Networking • SJA1110: Multi-Gig Safe and Secure TSN Ethernet Switch with Integrated 100BASE-T1 PHYs • TJA1120: TJA1120, ASIL B Compliant Automotive Ethernet 1000BASE-T1 PHY Transceiver • TJA1104: TJA1104, MACsec Enabled ASIL B Compliant Automotive Ethernet 100BASE-T1 PHY Transceiver • SJA1124: Quad LIN Commander Transceiver with LIN Commander Controller • TJA1463: CAN Signal Improvement Capability Transceiver with Sleep Mode • VR5510: Multi-Channel (9) PMIC for S32G Processor – 8 High Power, 1 Low Power, Fit for ASIL D Safety Level • PF53: 12 A / 8 A / 15 A Core Supply Regulator with AVP and Watchdog • FS26: Safety System Basis Chip with Low Power, for ASIL D Systems • PF5030: Multi-Channel PMIC for Automotive Applications • FS86: Safety System Basis Chip For Domain Controller, Fit For ASIL B and D
ECU Node	<ul style="list-style-type: none"> • S32M2: S32M2 Integrated Solution for 12V Motor Control • S32K3: S32K3 Microcontrollers for Automotive General Purpose • S32K1: S32K1 Microcontrollers for Automotive General Purpose • S32K39-37: S32K39/37/36 Microcontrollers for Electrification Applications • TJA1463: CAN Signal Improvement Capability Transceiver with Sleep Mode • TJA1103: TJA1103, ASIL B Compliant Automotive Ethernet 100BASE-T1 PHY Transceiver • TJA1104: TJA1104, MACsec Enabled ASIL B Compliant Automotive Ethernet 100BASE-T1 PHY Transceiver • FS24: Safety Mini CAN FD SBC for Automotive Applications Fit for ASIL-B • FS23: Safety System Basis Chip (SBC) Family with Power Management, CAN and LIN • FS26: Safety System Basis Chip with Low Power, for ASIL D Systems

Zone Controller Reference Design Block Diagram

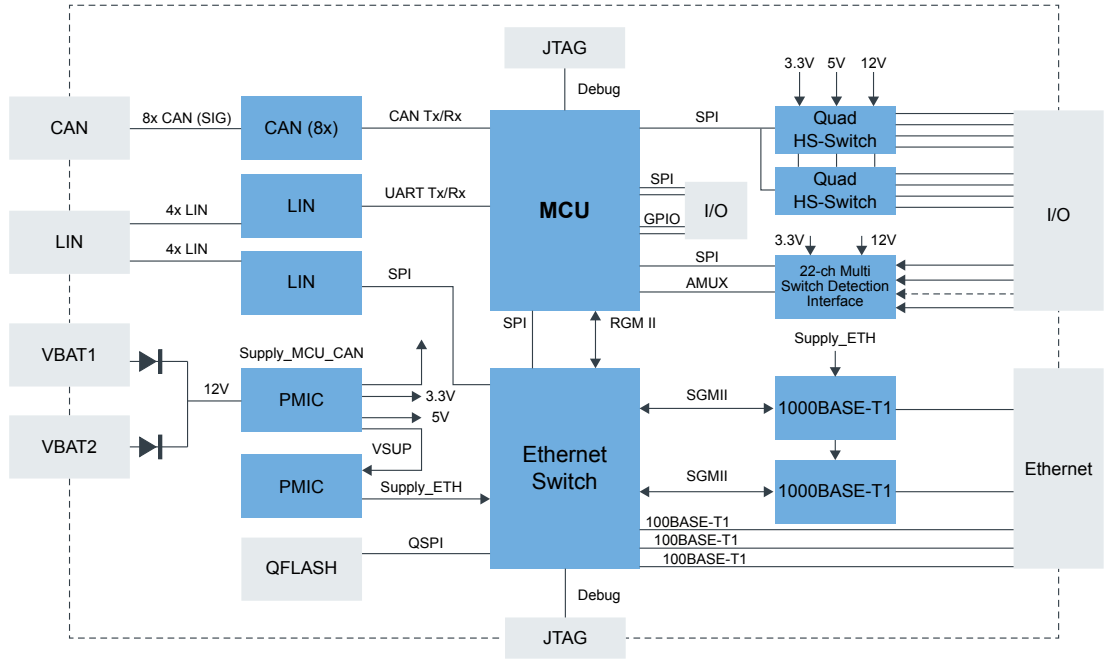

■ NXP Technology ■ Non NXP Technology □ Optional Technology

Recommended Products for Zone Controller Reference Design

CAN	<ul style="list-style-type: none"> • TJA1463: CAN Signal Improvement Capability Transceiver with Sleep Mode
LIN	<ul style="list-style-type: none"> • TJA1124: Quad LIN Commander Transceiver for In-Vehicle Subnetworks
Second LIN	<ul style="list-style-type: none"> • SJA1124: Quad LIN Commander Transceiver with LIN Commander Controller
PMIC	<ul style="list-style-type: none"> • FS26: Safety System Basis Chip with Low Power, for ASIL D Systems

MCU	<ul style="list-style-type: none"> • S32K3: S32K3 Microcontrollers for Automotive General Purpose
Quad HS-Switch	<ul style="list-style-type: none"> • XS2410: Quad 100 mΩ / Dual 50 mΩ, 3.0 V to 60 V High-Side Switch
22Ch MSDI	<ul style="list-style-type: none"> • MC33978: 22 I/O MSDI Programmable Current Analog Mux
1Giga Ethernet Phy	<ul style="list-style-type: none"> • TJA1121: TJA1121, MACsec Enabled ASIL B Compliant Automotive Ethernet 1000BASE-T1 PHY Transceiver
Ethernet Switch	<ul style="list-style-type: none"> • SJA1110: Multi-Gig Safe and Secure TSN Ethernet Switch with Integrated 100BASE-T1 PHYs

Zone Control POC Block Diagram

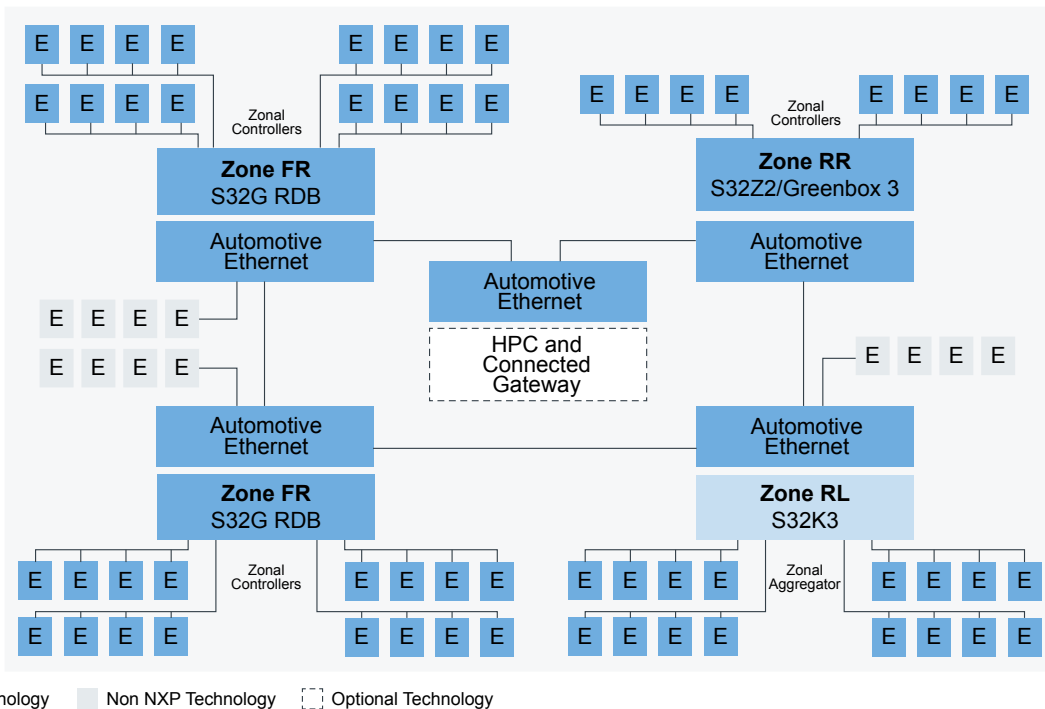

Recommended Products for Zone Control POC

Zone FR	<ul style="list-style-type: none"> • S32G2: S32G2 Processors for Vehicle Networking • S32G3: S32G3 Processors for Vehicle Networking • VR5510: Multi-Channel (9) PMIC for S32G Processor – 8 High Power, 1 Low Power, Fit for ASIL D Safety Level • PF53: 12 A / 8 A / 15 A Core Supply Regulator with AVP and Watchdog
Zone RR	<ul style="list-style-type: none"> • S32Z2: S32Z2 Safe and Secure High-Performance Real-Time Processors • FS86: Safety System Basis Chip For Domain Controller, Fit For ASIL B and D • PF5030: Multi-Channel PMIC for Automotive Applications
Zone RL	<ul style="list-style-type: none"> • S32K3: S32K3 Microcontrollers for Automotive General Purpose • FS26: Safety System Basis Chip with Low Power, for ASIL D Systems
Automotive Ethernet	<ul style="list-style-type: none"> • TJA1121: TJA1121, MACsec Enabled ASIL B Compliant Automotive Ethernet 1000BASE-T1 PHY Transceiver • TJA1120: TJA1120, ASIL B Compliant Automotive Ethernet 1000BASE-T1 PHY Transceiver

- | | |
|--|---|
| | <ul style="list-style-type: none">• TJA1104: TJA1104, MACsec Enabled ASIL B Compliant Automotive Ethernet 100BASE-T1 PHY Transceiver• SJA1110: Multi-Gig Safe and Secure TSN Ethernet Switch with Integrated 100BASE-T1 PHYs |
|--|---|

View our complete solution for [Automotive Zone Controller](#).

Note: The information on this document is subject to change without notice.

www.nxp.com

NXP and the NXP logo are trademarks of NXP B.V. All other product or service names are the property of their respective owners. The related technology may be protected by any or all of patents, copyrights, designs and trade secrets. All rights reserved. © 2024 NXP B.V.