

# IMXLUG

## i.MX Linux User's Guide

Rev. LF6.6.3\_1.0.0 — 29 March 2024

User guide

### Document information

Information	Content
Keywords	i.MX, Linux, LF6.6.3_1.0.0
Abstract	This document describes how to build and install the i.MX Linux OS BSP, where BSP stands for Board Support Package, on the i.MX platform. It also covers special i.MX features and how to use them.



## 1 Overview

---

This document describes how to build and install the i.MX Linux OS BSP, where BSP stands for Board Support Package, on the i.MX platform. It also covers special i.MX features and how to use them.

The document also provides the steps to run the i.MX platform, including board DIP switch settings, and instructions on configuring and using the U-Boot bootloader.

The later chapters describe how to use some i.MX special features when running the Linux OS kernel.

Features covered in this guide may be specific to particular boards or SoCs. For the capabilities of a particular board or SoC, see the *i.MX Linux Release Notes* (IMXLXRN).

### 1.1 Audience

This document is intended for software, hardware, and system engineers who are planning to use the product, and for anyone who wants to know more about the product.

### 1.2 Conventions

This document uses the following conventions:

- `Courier New` font: This font is used to identify commands, explicit command parameters, code examples, expressions, data types, and directives.

### 1.3 Supported hardware SoCs and boards

These are the systems covered in this guide:

- i.MX 6Quad SABRE-SD board and platform
- i.MX 6DualLite SABRE-SD platform
- i.MX 6SoloX SABRE-SD platform
- i.MX 7Dual SABRE-SD platform
- i.MX 6QuadPlus SABRE-SD platform
- i.MX 6UltraLite EVK platform
- i.MX 6ULL EVK platform
- i.MX 6ULZ EVK platform
- i.MX 7ULP EVK platform
- i.MX 8QuadMax MEK board
- i.MX 8QuadXPlus MEK platform
- i.MX 8DualXLite EVK Platform
- i.MX 8M Quad EVK platform
- i.MX 8M Mini EVK Board
- i.MX 8M Nano EVK Board
- i.MX 8M Plus EVK board
- i.MX 8DualX MEK Board
- i.MX 8ULP EVK Board
- i.MX 93 EVK board
- i.MX 93 QSB board
- i.MX 95 EVK board

Some abbreviations are used in places in this document.

- SABRE-SD refers to the i.MX 6Quad SABRE-SD, i.MX 6DualLite SABRE-SD, i.MX 6QuadPlus SABRE-SD, and i.MX 7Dual SABRE-SD boards.
- SoloX or SX refers to the i.MX 6SoloX SABRE-SD boards.
- 6UL refers to the i.MX 6UltraLite board.
- 6ULL refers to the i.MX 6ULL board.
- 6ULZ refers to the i.MX 6ULZ board.
- 7ULP refers to the i.MX 7Ultra Low Power platform.
- 8QXP refers to the 8QuadXPlus platform.
- 8QM refers to the 8QuadMax platform.
- 8MQ refers to the 8M Quad platform.
- 8MM refers to the 8M Mini platform.
- 8MN refers to the 8M Nano platform.
- 8MP refers to the 8M Plus platform.
- 8DXL refers to the 8DualXLite platform.
- 8DX refers to the 8DualX platform.
- 8ULP refers to the i.MX 8Ultra Low Power platform.
- i.MX 93 refers to the i.MX 93 EVK board.

## 1.4 References

i.MX has multiple families supported in software. The following are the listed families and SoCs per family. The i.MX Linux Release Notes describes which SoC is supported in the current release. Some previously released SoCs might be buildable in the current release but not validated if they are at the previous validated level.

- i.MX 6 Family: 6QuadPlus, 6Quad, 6DualLite, 6SoloX, 6SLL, 6UltraLite, 6ULL, 6ULZ
- i.MX 7 Family: 7Dual, 7ULP
- i.MX 8 Family: 8QuadMax, 8QuadPlus, 8ULP
- i.MX 8M Family: 8M Plus, 8M Quad, 8M Mini, 8M Nano
- i.MX 8X Family: 8QuadXPlus, 8DXL
- i.MX 9 Family: i.MX 93, i.MX 95

This release includes the following references and additional information.

- *i.MX Linux Release Notes* (IMXLXRN) - Provides the release information.
- *i.MX Linux User's Guide* (IMXLUG) - Provides the information on installing U-Boot and Linux OS and using i.MX-specific features.
- *i.MX Yocto Project User's Guide* (IMXLXYOCTOUG) - Describes the board support package for NXP development systems using Yocto Project to set up host, install tool chain, and build source code to create images.
- *i.MX Machine Learning User's Guide* (IMXMLUG) - Provides the machine learning information.
- *i.MX Linux Reference Manual* (IMXLXRM) - Provides the information on Linux drivers for i.MX.
- *i.MX Graphics User's Guide* (IMXGRAPHICUG) - Describes the graphics features.
- *i.MX Porting Guide* (IMXXBSPPG) - Provides the instructions on porting the BSP to a new board.
- *i.MX VPU Application Programming Interface Linux Reference Manual* (IMXVPUAPI) - Provides the reference information on the VPU API on i.MX 6 VPU.
- *Harpoon User's Guide* (IMXHPUG) - Presents the Harpoon release for i.MX 8M device family.
- *i.MX Digital Cockpit Hardware Partitioning Enablement for i.MX 8QuadMax* (IMXDCHPE) - Provides the i.MX Digital Cockpit hardware solution for i.MX 8QuadMax.
- *i.MX DSP User's Guide* (IMXDSPUG) - Provides the information on the DSP for i.MX 8.
- *i.MX 8M Plus Camera and Display Guide* (IMX8MPCDUG) - Provides the information on the ISP Independent Sensor Interface API for the i.MX 8M Plus.

- *EdgeLock Enclave Hardware Security Module API (RM00284)* - This document is a software reference description of the API provided by the i.MX 8ULP, i.MX 93, and i.MX 95 Hardware Security Module (HSM) solutions for the EdgeLock Enclave (ELE) Platform.

The quick start guides contain basic information on the board and setting it up. They are on the NXP website.

- [SABRE Platform Quick Start Guide \(IMX6QSDPQSG\)](#)
- [SABRE Board Quick Start Guide \(IMX6QSDBQSG\)](#)
- [i.MX 6UltraLite EVK Quick Start Guide \(IMX6ULTRALITEQSG\)](#)
- [i.MX 6ULL EVK Quick Start Guide \(IMX6ULLQSG\)](#)
- [SABRE Automotive Infotainment Quick Start Guide \(IMX6SABREINFOQSG\)](#)
- [i.MX 7Dual SABRE-SD Quick Start Guide \(SABRESDBIMX7DUALQSG\)](#)
- [i.MX 8M Quad Evaluation Kit Quick Start Guide \(IMX8MQUADEVKQSG\)](#)
- [i.MX 8M Mini Evaluation Kit Quick Start Guide \(8MMINIEVKQSG\)](#)
- [i.MX 8M Nano Evaluation Kit Quick Start Guide \(8MNANOEVKQSG\)](#)
- [i.MX 8QuadXPlus Multisensory Enablement Kit Quick Start Guide \(IMX8QUADXPLUSQSG\)](#)
- [i.MX 8QuadMax Multisensory Enablement Kit Quick Start Guide \(IMX8QUADMAXQSG\)](#)
- [i.MX 8M Plus Evaluation Kit Quick Start Guide \(IMX8MPLUSQSG\)](#)
- [i.MX 8ULP EVK Quick Start Guide \(IMX8ULPQSG\)](#)
- [i.MX 8ULP EVK9 Quick Start Guide \(IMX8ULPEVK9QSG\)](#)
- [i.MX 93 EVK Quick Start Guide \(IMX93EVKQSG\)](#)
- [i.MX 93 9x9 QSB Quick Start Guide \(93QSBQSG\)](#)

Documentation is available online at [nxp.com](http://nxp.com).

- i.MX 6 information is at [nxp.com/IMX6series](http://nxp.com/IMX6series)
- i.MX SABRE information is at [nxp.com/imxSABRE](http://nxp.com/imxSABRE)
- i.MX 6UltraLite information is at [nxp.com/iMX6UL](http://nxp.com/iMX6UL)
- i.MX 6ULL information is at [nxp.com/iMX6ULL](http://nxp.com/iMX6ULL)
- i.MX 7Dual information is at [nxp.com/iMX7D](http://nxp.com/iMX7D)
- i.MX 7ULP information is at [nxp.com/imx7ulp](http://nxp.com/imx7ulp)
- i.MX 8 information is at [nxp.com/imx8](http://nxp.com/imx8)
- i.MX 6ULZ information is at [nxp.com/imx6ulz](http://nxp.com/imx6ulz)
- i.MX 93 information is at [nxp.com/imx93](http://nxp.com/imx93)
- i.MX 95 information is at [nxp.com/imx95](http://nxp.com/imx95)

The latest DDR configuration and test tools are available online at [nxp.com](http://nxp.com) and at NXP Community:

- i.MX 6/7:  
[i.MX 6/7 Series DDR Tool Release](#)
- i.MX 8:  
[i.MX 8M Family DDR Tool Release](#)  
[i.MX 8/8X Family DDR Tools Release](#)
- i.MX 9 series:  
[Config Tools for i.MX Applications Processors](#)

## 2 Introduction

The i.MX Linux BSP is a collection of binary files, source code, and support files that can be used to create a U-Boot bootloader, a Linux kernel image, and a root file system for i.MX development systems. The Yocto Project is the framework of choice to build the images described in this document, although other methods can be used.

All the information on how to set up the Linux OS host, how to run and configure a Yocto Project, generate an image, and generate a rootfs, are covered in the *i.MX Yocto Project User's Guide* (IMXLXYOCTOUG).

When Linux OS is running, this guide provides information on how to use some special features that i.MX SoCs provide. The release notes provide the features that are supported on a particular board.

### 3 Basic Terminal Setup

The i.MX boards can communicate with a host server (Windows OS or Linux OS) using a serial cable. Common serial communication programs such as HyperTerminal, Tera Term, or PuTTY can be used. The example below describes the serial terminal setup using HyperTerminal on a host running Windows OS.

The i.MX 6Quad/QuadPlus/DualLite SABRE-AI boards connect to the host server using a serial cable.

The other i.MX boards connect the host driver using the micro-B USB connector.

1. Connect the target and the PC running Windows OS using a cable mentioned above.
2. Open HyperTerminal on the PC running Windows OS and select the settings as shown in the following figure.

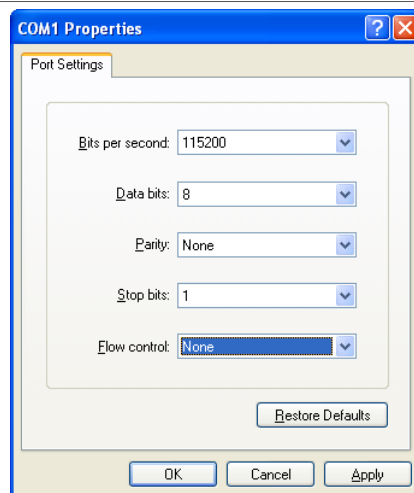

Figure 1. Teraterm settings for terminal setup

The i.MX 8 board connects the host driver using the micro USB connector. The USB to serial driver can be found under [www.ftdichip.com/Drivers/VCP.htm](http://www.ftdichip.com/Drivers/VCP.htm). The FT4232 USB to serial converter provides four serial ports. The i.MX 8 board uses the first port for the Arm Cortex-A cores console and the second port for SCU's console. Users need to select the first port (COM) in the terminal setup. The i.MX 8DXL board uses the third and fourth ports respectively for Arm Cortex-A cores console and SCU console.

## 4 Booting Linux OS

Before booting the Linux OS kernel on an i.MX board, copy the images (U-Boot, Linux kernel, device tree, and rootfs) to a boot device and set the boot switches to boot that device. There are various ways to boot the Linux OS for different boards, boot devices, and results desired. This section describes how to prepare a boot device, where files need to be in the memory map, how to set switches for booting, and how to boot Linux OS from U-Boot.

### 4.1 Software overview

This section describes the software needed for the board to be able to boot and run Linux OS.

To boot a Linux image on i.MX 6 and i.MX 7, the following elements are needed:

- Bootloader (U-Boot)
- Linux kernel image (zImage)
- A device tree file (.dtb) for the board being used
- A root file system (rootfs) for the particular Linux image
- Arm Cortex-M4 image for i.MX 7ULP

To boot a Linux image on i.MX 8QuadMax, i.MX 8QuadXPlus, and i.MX 8DXL, multiple elements are needed:

- Bootloader (imx-boot built by imx-mkimage, which is a tool that combines firmware and U-Boot to create a bootloader for i.MX 8), which includes U-Boot, Arm Trusted Firmware, DCD file, System controller firmware, and the SECO firmware since i.MX 8QuadMax/i.MX 8QuadXPlus B0 and i.MX 8DXL A1.
- (Optional) Arm Cortex-M4 image
- Linux kernel image (Image built by linux-imx)
- A device tree file (.dtb) for the board being used
- A root file system (rootfs) for the particular Linux image

On i.MX 8M Quad, i.MX 8M Mini, i.MX 8M Nano, and i.MX 8M Plus, multiple elements are needed:

- imx-boot (built by imx-mkimage), which includes SPL, U-Boot, Arm Trusted Firmware, DDR firmware
- HDMI firmware (only supported by i.MX 8M Quad)
- Linux kernel image
- A device tree file (.dtb) for the board being used.
- A root file system (rootfs) for the particular Linux image

On i.MX 8ULP, four elements are needed:

- imx-boot (built by imx-mkimage), which includes SPL, U-Boot, Arm Trusted Firmware, OP-TEE, uPower Firmware, Sentinel Firmware, and Arm Cortex-M33 image
- Linux kernel image
- A device tree file (.dtb) for the board being used
- A root file system (rootfs) for the particular Linux image

On i.MX 93, multiple elements are needed:

- imx-boot (built by imx-mkimage), which includes SPL, U-Boot, Arm Trusted Firmware, OP-TEE, Sentinel Firmware, DDR PHY Firmware
- Linux kernel image
- (Optional) Arm Cortex-M33 image
- A device tree file (.dtb) for the board being used
- A root file system (rootfs) for the particular Linux image

The system can be configured for a specific graphical backend. For i.MX 8, the graphical backend is XWayland. For i.MX 7ULP, the default backend is XWayland.

#### 4.1.1 Bootloader

U-Boot is the tool recommended as the bootloader for i.MX 6 and i.MX 7. i.MX 8 and i.MX 9 require a bootloader that includes U-Boot as well as other components described below. U-Boot must be loaded onto a device to be able to boot from it. U-Boot images are board-specific and can be configured to support booting from different sources.

The pre-built or Yocto project default bootloader names start with the name of the bootloader followed by the name of the platform and board and followed by the name of the device that this image is configured to boot

from: `u-boot-[platform][board]_[machine_configuration].bin`. If no boot device is specified, it boots from SD/MMC.

The manufacturing tool can be used to load U-Boot onto all devices with i.MX 6 and i.MX 7. U-Boot can be loaded directly onto an SD card using the Linux `dd` command. U-Boot can be used to load a U-Boot image onto some other devices.

On i.MX 8, the U-Boot cannot boot the device by itself. The i.MX 8 pre-built images or Yocto Project default bootloader is `imx-boot` for the SD card, which is created by the `imx-mkimage`. The `imx-boot` binary includes the U-Boot, Arm trusted firmware, DCD file (8QuadMax/8QuadXPlus/8DXL), system controller firmware (8QuadMax/8QuadXPlus/8DXL), SPL (8M SoC), DDR firmware (8M), HDMI firmware (8M Quad), and SECO firmware (8QuadMax/8QuadXPlus/8DXL).

On i.MX 8M SoC, the second program loader (SPL) is enabled in U-Boot. SPL is implemented as the first-level bootloader running on TCML (For i.MX 8M Nano and i.MX 8M Plus, the first-level bootloader runs in OCRAM). It is used to initialize DDR and load U-Boot, U-Boot DTB, Arm trusted firmware, and TEE OS (optional) from the boot device into the memory. After SPL completes loading the images, it jumps to the Arm trusted firmware BL31 directly. The BL31 starts the optional BL32 (TEE OS) and BL33 (U-Boot) for continue booting kernel.

In `imx-boot`, the SPL is packed with DDR Firmware together, so that ROM can load them into Arm Cortex-M4 TCML or OCRAM (only for i.MX 8M Nano and i.MX 8M Plus). The U-Boot, U-Boot DTB, Arm Trusted firmware, and TEE OS (optional) are packed into a FIT image, which is finally built into `imx-boot`.

#### 4.1.2 Linux kernel image and device tree

This i.MX BSP contains a pre-built kernel image based on the 6.6.3 version of the Linux kernel and the device tree files associated with each platform.

The same kernel image is used for all the i.MX 6 and i.MX 7 with name `zImage`. Device trees are tree data structures, which describe the hardware configuration allowing a common kernel to be booted with different pin settings for different boards or configurations. Device tree files use the `.dtb` extension. The configuration for a device tree can be found in the Linux source code under `arch/arm/boot/dts` in the `*.dts` files.

The i.MX Linux delivery package contains pre-built device tree files for the i.MX boards in various configurations. Filenames for the prebuilt images are named `Image-[platform]-[board]-[configuration].dtb`. For example, the device tree file of the i.MX 8QuadMax MEK board is `Image-imx8qm-mek.dtb`.

For i.MX 6 and i.MX 7, the `*ldo.dtb` device trees are used for LDO-enabled feature support. By default, the LDO bypass is enabled. If your board has the CPU set to 1.2 GHz, you should use the `*ldo.dtb` device tree instead of the default, because LDO bypass mode is not supported on the CPU at 1.2 GHz. The device tree `*hdcp.dtb` is used to enable the HDCP feature because of a pin conflict, which requires this to be configured at build time.

On i.MX 8, i.MX 8M, i.MX 8ULP, and i.MX 93, and i.MX 91P, the kernel is 64 bit and device trees are located in the `arch/arm64/boot/dts/freescale` folder and use the `dts` extension. The kernel is built using `linux-imx` software provided in the release package and the filename starting with `Image`.

#### 4.1.3 Root file system

The root file system package (or `rootfs`) provides `busybox`, common libraries, and other fundamental elements.

The i.MX BSP package contains several root file systems. They are named with the following convention: `[image name]-[backend]-[platform][board].[ext4|wic]`. The `ext4` extension indicates a standard file system. It can be mounted as NFS, or its contents can be stored on a boot media such as an SD/MMC card.

The graphical backend to be used is also defined by the `rootfs`.

## 4.2 Universal update utility

The Universal Update Utility (UUU) runs on a Windows or Linux OS host and is used to download images to different devices on an i.MX board.

### 4.2.1 Downloading UUU

Download UUU version 1.5.125 or higher from <https://github.com/NXPmicro/mfgtools/releases>.

### 4.2.2 Using UUU

To use the UUU for i.MX 6, i.MX 7, i.MX 8, and i.MX 9, follow the instructions below:

1. Connect a USB cable from a computer to the USB OTG/TYPED C (or Micro-B, depending on board) port on the board for download link.
2. Connect a USB cable from the OTG-to-UART port to the computer for console output.
3. Open a Terminal emulator program. See Section "Section 3" in this document.
4. Set the boot pin to serial download mode mode. See Section "Section 4.5.11" in this document.

To use the UUU for i.MX 8ULP EVK, follow the instructions below:

- To burn single-boot image and rootfs to eMMC, run the following command:

```
uuu -b emmc_all imx-boot-imx8ulpevk-sd.bin-flash_singleboot_m33
<rootfs.wic.zst>
```

- To burn single-boot image to FlexSPI2 NOR flash, run the following command:

```
uuu -b qspi imx-boot-imx8ulpevk-fspi.bin-flash_singleboot_m33_flexspi
```

- To burn dual-boot image and rootfs to eMMC and FlexSPI0 NOR flash, perform the following steps:

1. Prepare `imx-boot-imx8ulpevk-sd.bin-flash_singleboot_m33`, `imx-boot-imx8ulpevk-sd.bin-flash_dualboot`, `imx-boot-imx8ulpevk-sd.bin-flash_dualboot_m33`, and `<rootfs.wic>`.
2. Update the UUU script file `uuu_8ulp_dual.auto` with the file path and name of the images above.
3. Run `uuu mfgtools/scripts/samples/uuu_8ulp_dual.auto`.

For detailed usage of UUU, see [github.com/NXPmicro/mfgtools/wiki](https://github.com/NXPmicro/mfgtools/wiki).

For example, the following command writes `rootfs.wic` into eMMC.

```
uuu -b emmc_all <bootloader> <rootfs.wic>
```

The following command decompresses `zst` file and writes into eMMC:

```
uuu -b emmc_all <bootloader> <rootfs.wic.zst/*>
```

The following command executes downloading and bootloader (SPL and U-Boot) by USB:

```
uuu -b spl <bootloader>
```

The following command burns boot image into FlexSPI NAND:

```
uuu -b spi_nand <nand_uuu_fw> <bootloader>
```



The following command burns into eMMC (If only one board is supported in such a release package and the board supports eMMC chip):

```
uuu <release package>.zip
```

**Note:**

*For i.MX 8QuadXPlus B0, UUU flashes the eMMC image to boot partition with 32 KB offset. It may not be compatible with all eMMC devices. It is recommended to enable eMMC fastboot mode and use the UUU kernel version script to flash the eMMC image to boot partition with 0 offset.*

### 4.3 Preparing an SD/MMC card to boot

This section describes the steps to prepare an SD/MMC card to boot up an i.MX board using a Linux host machine. These instructions apply to SD and MMC cards although for brevity, and usually only the SD card is listed.

For a Linux image to be able to run, four separate pieces are needed:

- Linux OS kernel image (zImage/Image)
- Device tree file (\*.dtb)
- Bootloader image
- Root file system (for example, EXT4)

The Yocto Project build creates an SD card image that can be flashed directly. This is the simplest way to load everything needed onto the card with one command.

A .wic image contains all four images properly configured for an SD card. The release contains a pre-built .wic image that is built specifically for the one board configuration. It runs the Wayland graphical backend. It does not run on other boards unless U-Boot, the device tree, and rootfs are changed.

When more flexibility is desired, the individual components can be loaded separately, and those instructions are included here as well. An SD card can be loaded with the individual components one-by-one or the .wic image can be loaded and the individual parts can be overwritten with the specific components.

The rootfs on the default .wic image is limited to a bit less than 4 GB, but re-partitioning and re-loading the rootfs can increase that to the size of the card. The rootfs can also be changed to specify the graphical backend that is used.

The device tree file (.dtb) contains board and configuration-specific changes to the kernel. Change the device tree file to change the kernel for a different i.MX board or configuration.

By default, the release uses the following layout for the images on the SD card. The kernel image and DTB move to use the FAT partition without a fixed raw address on the SD card. The users have to change the U-Boot boot environment if the fixed raw address is required.

**Table 1. Image layout**

Start address (sectors)	Size (sectors)	Format	Description
0x400 bytes (2)	0x9FFC00 bytes (20478)	RAW	i.MX 6 and i.MX 7 U-Boot and reserved area
0x8400 (66)	0x9F7C00 (20414)	RAW	i.MX 8M Quad and i.MX 8M Mini imx-boot reserved area
0x8000 (64)	0x9F8000 (20416)	RAW	i.MX 8QuadMax/8QuadXPlus/8M Nano/8M Plus/8DXL/8DualX/8ULP, i.MX 93, and i.MX 95
0xa00000 bytes (20480)	500 MB (1024000)	FAT	Kernel Image and DTBs

Table 1. Image layout...continued

Start address (sectors)	Size (sectors)	Format	Description
0x25800000 bytes (1228800)	Remaining space	Ext3/Ext4	Rootfs

### 4.3.1 Preparing the card

An SD/MMC card reader, such as a USB card reader, is required. It is used to transfer the bootloader and kernel images to initialize the partition table and copy the root file system. To simplify the instructions, it is assumed that a 4 GB SD/MMC card is used.

Any Linux distribution can be used for the following procedure.

The Linux kernel running on the Linux host assigns a device node to the SD/MMC card reader. The kernel might decide the device node name or udev rules might be used. In the following instructions, it is assumed that udev is not used.

To identify the device node assigned to the SD/MMC card, carry out the following command:

```
$ cat /proc/partitions
major minor #blocks name
 8      0   78125000 sda
 8      1   75095811 sda1
 8      2           1 sda2
 8      5    3028221 sda5
 8     32  488386584 sdc
 8     33  488386552 sdc1
 8     16    3921920 sdb
 8     18    3905535 sdb1
```

In this example, the device node assigned is /dev/sdb (a block is 1024 Bytes).

**Note:** Make sure that the device node is correct for the SD/MMC card. Otherwise, it may damage your operating system or data on your computer.

### 4.3.2 Copying the full SD card image

The SD card image (with the extension .wic) contains U-Boot, the Linux image and device trees, and the rootfs for a 4 GB SD card. The image can be installed on the SD card with one command if flexibility is not required.

Carry out the following command to copy the SD card image to the SD/MMC card. Change sdx below to match the one used by the SD card.

```
$ sudo dd if=<image name>.wic of=/dev/sdx bs=1M && sync
```

The entire contents of the SD card are replaced. If the SD card is larger than 4 GB, the additional space is not accessible.

### 4.3.3 Partitioning the SD/MMC card

The full SD card image already contains partitions. This section describes how to set up the partitions manually. This needs to be done to individually load the bootloader, kernel, and rootfs.

There are various ways to partition an SD card. Essentially, the bootloader image needs to be at the beginning of the card, followed by the Linux image and the device tree file. These can either be in separate partitions or not. The root file system needs to be in a partition that starts after the Linux section. Make sure that each section has enough space. The example below creates two partitions.

On most Linux host operating systems, the SD card is mounted automatically upon insertion. Therefore, before running `fdisk`, make sure that the SD card is unmounted if it was previously mounted (through `sudo umount /dev/sdx`).

Start by running `fdisk` with root permissions. Use the instructions above to determine the card ID. We are using `sdx` here as an example.

```
$ sudo fdisk /dev/sdx
```

Type the following parameters (each followed by <ENTER>):

```
p          [lists the current partitions]
d          [to delete existing partitions. Repeat this until no unnecessary
partitions
           are reported by the 'p' command to start fresh.]
n          [create a new partition]
p          [create a primary partition - use for both partitions]
1          [the first partition]
20480     [starting at offset sector]
1024000   [ending position of the first partition to be used for the boot
images]
p          [to check the partitions]
n
p
2
1228800   [starting at offset sector, which leaves enough space for the kernel,
           the bootloader and its configuration data]
<enter>   [using the default value will create a partition that extends to
           the last sector of the media]
p          [to check the partitions]
w          [this writes the partition table to the media and fdisk exits]
```

#### 4.3.4 Copying a bootloader image

This section describes how to load only the bootloader image when the full SD card image is not used. Execute the following command to copy the U-Boot image to the SD/MMC card.

```
$ sudo dd if=<U-Boot image> of=/dev/sdx bs=1k seek=<offset> conv=fsync
```

Where `offset` is:

- 1 - for i.MX 6 or i.MX 7
- 33 - for i.MX 8QuadMax A0, i.MX 8QuadXPlus A0, and i.MX 8M Quad, and i.MX 8M Mini
- 32 - for i.MX 8QuadXPlus B0, i.MX 8QuadMax B0, i.MX 8DualX, i.MX 8DXL, i.MX 8M Nano, i.MX 8M Plus, i.MX 8ULP, and i.MX 9

The sectors of SD/eMMC before the “offset” KB are reserved. It may include the partition table.

#### 4.3.5 Copying the kernel image and DTB file

This section describes how to load the kernel image and DTB when the full SD card image is not used. The pre-built SD card image uses the VFAT partition for storing kernel image and DTB, which requires a VFAT partition that is mounted as a Linux drive and the files are copied into it. This is the preferred method.

Another method that can be used is for users to put the kernel image and DTB to the fixed raw address of the SD card by using the `dd` command. The later method needs to modify the U-Boot default environment variables for loading the kernel image and DTB.

**Default: VFAT partition**

1. Format partition 1 on the card as VFAT with this command:

```
$ sudo mkfs.vfat /dev/sdx1
```

2. Mount the formatted partition with this command:

```
$ mkdir mountpoint
$ sudo mount /dev/sdx1 mountpoint
```

3. Copy the zImage and \*.dtb files to the mountpoint by using cp. The device tree names should match the one used by the variable specified by U-Boot. Unmount the partition with this command:

```
$ sudo umount mountpoint
```

**Alternative: Pre-defined raw address**

The following command can be used to copy the kernel image to the SD/MMC card:

For i.MX 6 and i.MX7, use this command:

```
$ sudo dd if=zImage_imx_v7_defconfig of=/dev/sdx bs=512 seek=2048 conv=fsync
```

For i.MX 8, use this command:

```
sudo dd if=Image-imx8qmsabreauto.bin of=/dev/sdx bs=512 seek=2048 conv=fsync
```

Each of them copies the kernel to the media at offset 1 MB (bs x seek = 512 x 2048 = 1 MB). The file `zImage_imx_v7_defconfig` refers to the `zImage` file created when using the `imx_v7_defconfig` configuration file, which supports both i.MX 6 and i.MX 7 SoCs.

The i.MX DTB image can be copied by using the copy command and copying the file to the 2nd partition or the following commands copy an i.MX DTB image to the SD/MMC card by using `dd` command.

Choose a command for your board:

```
$ sudo dd if=zImage-imx6qp-sabreauto.dtb of=/dev/sdx bs=512 seek=20480
conv=fsync
$ sudo dd if=zImage-imx6qp-sabresd.dtb of=/dev/sdx bs=512 seek=20480 conv=fsync
$ sudo dd if=zImage-imx6q-sabreauto.dtb of=/dev/sdx bs=512 seek=20480 conv=fsync
$ sudo dd if=zImage-imx6q-sabresd.dtb of=/dev/sdx bs=512 seek=20480 conv=fsync
$ sudo dd if=zImage-imx6sl-evk.dtb of=/dev/sdx bs=512 seek=20480 conv=fsync
$ sudo dd if=zImage-imx7d-sdb.dtb of=/dev/sdx bs=512 seek=20480 conv=fsync
```

For i.MX 6 and i.MX 7, the following command can be used to copy the kernel image to the boards, such as the i.MX 6UltraLite EVK board and i.MX 6ULL EVK board:

```
$ sudo dd if=zImage-imx6ul-14x14-evk.dtb of=/dev/sdx bs=512 seek=20480
conv=fsync
$ sudo dd if=zImage-imx6ull-14x14-evk.dtb of=/dev/sdx bs=512 seek=20480
conv=fsync
```

For i.MX 6 and i.MX 7, this copies the board-specific `.dtb` file to the media at offset 10 MB (bs x seek = 512 x 20480 = 10 MB).

**4.3.6 Copying the root file system (rootfs)**

This section describes how to load the rootfs image when the full SD card image is not used.

Copy the target file system to a partition that only contains the rootfs. This example uses partition 2 for the rootfs. First format the partition. The file system format `ext3` or `ext4` is a good option for the removable media due to the built-in journaling. Replace `sdX` with the partition in use in your configuration.

```
$ sudo mkfs.ext3 /dev/sdx2
Or
$ sudo mkfs.ext4 /dev/sdx2
```

Copy the target file system to the partition:

```
$ mkdir /home/user/mountpoint
$ sudo mount /dev/sdx2 /home/user/mountpoint
```

Extract a rootfs package to a directory: for example, extract `imx-image-multimedia-imx7ulpevk.tar.zst` to `/home/user/rootfs`:

```
$ cd /home/user/rootfs
$ tar -jxvf imx-image-multimedia-imx7ulpevk.tar.zst
```

The rootfs directory needs to be created manually.

Assume that the root file system files are located in `/home/user/rootfs` as in the previous step:

```
$ cd /home/user/rootfs
$ sudo cp -a * /home/user/mountpoint
$ sudo umount /home/user/mountpoint
$ sync
```

The file system content is now on the media.

**Note:** Copying the file system takes several minutes depending on the size of your rootfs.

## 4.4 Downloading images

Images can be downloaded to a device using a U-Boot image that is already loaded on the boot device or by using the Manufacturing Tool UUU. Use a terminal program to communicate with the i.MX boards.

### 4.4.1 Downloading images using U-Boot

The following sections describe how to download images using the U-Boot bootloader.

The commands described below are generally useful when using U-Boot. Additional commands and information can be found by typing `help` at the U-Boot prompt.

The U-Boot `print` command can be used to check environment variable values.

The `setenv` command can be used to set environment variable values.

#### 4.4.1.1 Flashing an Arm Cortex-M4 image on QuadSPI

i.MX 6SoloX SABRE-SD, i.MX 7ULP EVK, and i.MX 7Dual SABRE-SD boards have the Arm Cortex-M4 processor and QuadSPI memory that can be used to flash an image to it.

**Note:**

To enable the full features for i.MX 7ULP, burn the Arm Cortex-M4 image to QuadSPI. It is recommended to use the MFGTool script `uuu LF6.6.3_1.0.0_images_MX7ULPEVK.zip\uuu_sd_m4.auto` to burn both BSP and Arm Cortex-M4 images.

i.MX U-Boot provides a reference script on i.MX 7Dual SABRESB and i.MX 6SoloX SABRE-SD to flash the Arm Cortex-M4 image from the SD card. To execute the script, perform the following steps:

1. Copy the Arm Cortex-M4 image to the first VFAT partition of the boot SD card. Name the file to `m4_qspi.bin`.
2. Boot from the SD card.
3. Flash the Arm Cortex-M4 image from the SD card to the NOR flash on QuadSPI2 PortB CS0 on the i.MX 6SoloX SABRE-SD board or QuadSPI1 PortA CS0 offset 1 MB on the i.MX 7Dual SABRE-SD board.

```
U-Boot > run update_m4_from_sd
```

Alternatively, users can flash the Arm Cortex-M4 image from TFTP by performing the following steps:

1. Boot from the SD card.
2. TFTP the Arm Cortex-M4 image.

```
U-Boot > tftp ${loadaddr} m4_qspi.bin
```

3. Select the NOR flash on QuadSPI2 PortB CS0 on the i.MX 6SoloX SABRE-SD board.

```
U-Boot > sf probe 1:0
```

Select the NOR flash on QuadSPI1 PortA CS0 on the i.MX 7Dual SABRE-SD board and i.MX 7ULP EVK board.

```
U-Boot > sf probe 0:0
```

4. Flash the Arm Cortex-M4 image to the selected NOR flash. The erase size is `${filesize}`, around 64 Kbytes. This example assumes that it is 128 Kbytes.

```
U-Boot > sf erase 0x0 0x20000
U-Boot > sf write ${loadaddr} 0x0 ${filesize}
```

i.MX 7Dual SABRE-SD needs to program the Arm Cortex-M4 images to 1 MB offset, because the first 1 MB is used by the U-Boot image in QuadSPI.

```
U-Boot > sf erase 0x100000 0x20000
U-Boot > sf write ${loadaddr} 0x100000 ${filesize}
```

#### Note:

On i.MX 7Dual SABRE-SD, the Arm Cortex-M4 image on QuadSPI is supported only when the U-Boot image is built by the target `mx7dsabresd_qspi1_defconfig` booted by U-Boot from QuadSPI.

The default U-Boot for the i.MX 7Dual SABRESB board uses the Cortex-M4 image from the SD card and runs it on OCRAM.

On i.MX 7ULP EVK, the Arm Cortex-M4 image needs to be programmed. Otherwise, it will not boot.

#### 4.4.1.2 Downloading an image to MMC/SD

This section describes how to download U-Boot to an MMC/SD card that is not the one used to boot from.

Insert an MMC/SD card into the SD card slot. This is slot SD3 on i.MX 6 SABRE, SD2 on i.MX 6UltraLite EVK and i.MX 6ULL EVK, SD1 on i.MX 7Dual SABRE-SD and i.MX 7ULP EVK (MicroSD), and SD1 on i.MX 8QuadMax MEK, 8QuadXPlus MEK, and i.MX 8M Quad EVK.

#### Note:

To enable the full features for i.MX 7ULP, burn the Arm Cortex-M4 image to QuadSPI. It is recommended to use the MfgTool script `uuu LF6.6.3_1.0.0_images_MX7ULPEVK.zip\uuu_sd_m4.auto` to burn both BSP and Arm Cortex-M4 images.

For i.MX 7ULP, to burn the Arm Cortex-M4 image to QuadSPI, perform the following steps:

1. Copy the Arm Cortex-M4 image to the SD card `vfat` partition, insert the SD card, and then boot to the U-Boot console.
2. Probe the Quad SPI in U-Boot, and erase an enough big size QuardSPI flash space for this Arm Cortex-M4 image.

```
U-Boot > sf probe
U-Boot > sf erase 0x0 0x30000;
```

3. Read the Arm Cortex-M4 image (in the first `vfat` partition on the SD card) to memory address, the Arm Cortex-M4 image name is `sdk20-app.img` here.

```
U-Boot > fatload mmc 0:1 0x62000000 sdk20-app.img;
```

4. Write the Arm Cortex-M4 image to the QuardSPI.

```
U-Boot > sf write 0x62000000 0x0 0x30000
```

To flash the original U-Boot, see Section [Section 4.3](#).

The U-Boot bootloader is able to download images from a TFTP server into RAM and to write from RAM to an SD card. For this operation, the Ethernet interface is used and U-Boot environment variables are initialized for network communications.

The boot media contains U-Boot, which is executed upon power-on. Press any key before the value of the U-Boot environment variable, `bootdelay`, decreases and before it times out. The default setting is 3 seconds to display the U-Boot prompt.

1. To clean up the environment variables stored on MMC/SD to their defaults, execute the following command in the U-Boot console:

```
U-Boot > env default -f -a U-Boot > saveenv U-Boot > reset
```

2. Configure the U-Boot environment for network communications. The following is an example. The lines preceded by the `"#"` character are comments and have no effect.

```
U-Boot > setenv serverip <your TFTPserver ip>
U-Boot > setenv bootfile <your kernel zImage/Image name on the TFTP server>
U-Boot > setenv fdtfile <your dtb image name on the TFTP server>
```

The user can set a fake MAC address through `ethaddr` environment if the MAC address is not fused.

```
U-Boot > setenv ethaddr 00:01:02:03:04:05
U-Boot > save
```

3. Copy `zImage/Image` to the TFTP server. Then download it to RAM:

```
U-Boot > dhcp
```

4. Query the information about the MMC/SD card.

```
U-Boot > mmc devU-Boot > mmcinfo
```

5. Check the usage of the `mmc` command. The `blk#` is equal to `<the offset of read/write>/<block length of the card>`. The `cnt` is equal to `<the size of read/write>/<block length of the card>`.

```
U-Boot > help mmc
mmc - MMC sub system
```

## Usage:

```

mmc read addr blk# cnt
mmc write addr blk# cnt
mmc erase blk# cnt
mmc rescan
mmc part - lists available partition on current mmc device
mmc dev [dev] [part] - show or set current mmc device [partition]
mmc list - lists available devices

```

6. Program the kernel zImage/Image located in RAM at  $\{\text{loadaddr}\}$  into the SD card. For example, the command to write the image with the size 0x800000 from  $\{\text{loadaddr}\}$  to the offset of 0x100000 of the microSD card. See the following examples for the definition of the MMC parameters.

```
blk# = (microSD Offset)/(SD block length) = 0x100000/0x200 = 0x800
```

```
cnt = (image Size)/(SD block length) = 0x800000/0x200 = 0x4000
```

This example assumes that the kernel image is equal to 0x800000. If the kernel image exceeds 0x800000, increase the image length. After issuing the TFTP command, filesize of the U-Boot environment variable is set with the number of bytes transferred. This can be checked to determine the correct size needed for the calculation. Use the U-Boot command printenv to see the value.

```

U-Boot > mmc dev 2 0
U-Boot > tftpboot ${loadaddr} ${bootfile}
### Suppose the kernel zImage is less than 8M.
U-Boot > mmc write ${loadaddr} 0x800 0x4000

```

7. Program the dtb file located in RAM at  $\{\text{fdt\_addr}\}$  into the microSD.

```

U-Boot > tftpboot ${fdt_addr} ${fdtfile}
U-Boot > mmc write ${fdt_addr} 0x5000 0x800

```

8. On i.MX 6 SABRE boards, you can boot the system from rootfs on SD card, using the HannStar LVDS as display. The kernel MMC module now uses a fixed mmcblk index for the uSDHC slot. The SD3 slot uses mmcblk2 on i.MX 6 SABRE boards, the SD1 slot uses mmcblk0 on the i.MX 7Dual SABRE-SD board, and the SD2 slot uses mmcblk1 on the i.MX 6UltraLite board and i.MX 6ULL EVK board. The SD1 slot uses mmcblk1 on i.MX 8 MEK boards and i.MX 8M boards.
9. Boot the board.

```

U-Boot > setenv bootcmd_mmc 'run bootargs_base mmcargs;mmc dev;mmc
read ${loadaddr} 0x800 0x4000;mmc read ${fdt_addr} 0x5000 0x800;bootz
${loadaddr} - ${fdt_addr}'
U-Boot > setenv bootcmd 'run bootcmd_mmc'
U-Boot > saveenv

```

#### 4.4.1.3 Using eMMC

There is an eMMC chip on i.MX SABRE boards, i.MX 8 MEK and EVK boards, i.MX 8M EVK boards, and i.MX 8ULP EVK boards. It is accessed through SDHC4 on i.MX 6 SABRE boards, SDHC3 on i.MX 7Dual SABRE-SD board, SDHC1 on i.MX 8 MEK/EVK boards and i.MX 8M EVK boards, and SDHC0 on i.MX 8ULP EVK board. The i.MX 7ULP EVK board also supports to rework eMMC on the MicroSD port. The following steps describe how to use this memory device.

#### Note:

To enable the full features for i.MX 7ULP, burn the Arm Cortex-M4 image to QuadSPI. It is recommended to use the MfgTool script `uuu_LF6.6.3_1.0.0_images_MX7ULPEVK.zip\uuu_sd_m4.auto` to burn both BSP and Arm Cortex-M4 images.



1. Execute the following command on the U-Boot console to clean up the environments stored on eMMC:

```
U-Boot > env default -f -a
U-Boot > save
U-Boot > reset
```

2. Configure the boot pin. Power on the board and set the U-Boot environment variables as required. For example,

```
U-Boot > setenv serverip <your tftpserver ip>
U-Boot > setenv bootfile <your kernel zImage/Image name on the tftp server>
U-Boot > setenv fdtfile <your dtb image name on the tftp server>
### The user can set fake MAC address via ethaddr enviroment if the MAC
address is not fused
U-Boot > setenv ethaddr 00:01:02:03:04:05
U-Boot > save
```

3. Copy zImage to the TFTP server. Then download it to RAM:

```
U-Boot > dhcp
```

4. Query the information about the eMMC chip.

```
U-Boot > mmc dev
U-Boot > mmcinfo
```

5. Check the usage of the `mmc` command. `blk#` is equal to <the offset of read/write>/<block length of the card>. `cnt` is equal to <the size of read/write>/<block length of the card>.

```
mmc read addr blk# cnt
mmc write addr blk# cnt
mmc erase blk# cnt
mmc rescan
mmc part - lists available partition on current mmc device
mmc dev [dev] [part] - show or set current mmc device [partition]
mmc list - lists available devices
```

6. Program the kernel zImage/Image into eMMC. For example, the command below writes the image with the size `0x800000` from `_${loadaddr}` to the offset `0x100000` of the eMMC chip. Here, the following equations are used: `0x800 = 0x100000/0x200`, `0x4000 = 0x800000/0x200`. The block size of this card is `0x200`. This example assumes that the kernel image is less than `0x800000` bytes. If the kernel image exceeds `0x800000`, enlarge the image length.

```
### Select mmc dev 2 (USDHC4) on the i.MX 6 SABRESD board:
U-Boot > mmc dev 2 0
### Select mmc dev 1 (USDHC3) on the i.MX 7Dual SABRESD board:
U-Boot > mmc dev 1 0
### Select mmc dev 1 (USDHC2) on the i.MX 6UltraLite EVK board:
U-Boot > mmc dev 1 0
### Select mmc dev 0 (USDHC1) on the i.MX 7ULP EVK board:
U-Boot > mmc dev 0 0
### Select mmc dev 0 (eMMC0) on the i.MX 8QuadMax MEK, i.MX 8QuadXPlus MEK,
i.MX 8M Quad, 8DualX, and 8DXL boards:
U-Boot > mmc dev 0 0
### select mmc dev 2 (USDHC3) on the i.MX 8M Mini EVK, i.MX 8M Nano EVK, and
i.MX 8M Plus EVK:
U-Boot > mmc dev 2 0
### select mmc dev 0 (USDHC0) on the i.MX 8ULP EVK
U-boot > mmc dev 0
### Suppose kernel zImage is less than 8 MB:
U-Boot > tftpboot ${loadaddr} ${bootfile}
```

```
U-Boot > mmc write ${loadaddr} 0x800 0x4000
```

7. Program the dtb file located in RAM at `${fdt_addr}` into the eMMC chip.

```
U-Boot > tftpboot ${fdt_addr} ${fdtfile}
U-Boot > mmc write ${fdt_addr} 0x5000 0x800
```

8. Boot up the system through the rootfs in eMMC, using the HannStar LVDS as display. The kernel MMC module now uses the fixed `mmcblk` indexes for the USDHC slots. The eMMC/SD4 slot on the i.MX 6 SABRE boards is `mmcblk3`. The eMMC5.0 on the i.MX 8QuadMax MEK board, i.MX 8QuadXPlus MEK board, and i.MX 8M Quad EVK board are `mmcblk0`. The eMMC5.0/SD3 slot on the i.MX 7Dual SABRE board is `mmcblk2`. eMMC is not populated on the i.MX 7Dual SABRE board.

```
U-Boot > setenv mmcboot 'run bootargs_base mmcargs; mmc dev 2;
mmc read ${loadaddr} 0x800 0x4000; mmc read ${fdt_addr} 0x5000 0x800;bootz
${loadaddr} - ${fdt_addr} '
U-Boot > setenv bootcmd 'run mmcboot'
U-Boot > saveenv
```

9. Boot up the system through the rootfs in eMMC, using the CLAA WVGA panel as display:

- For i.MX 6 boards:

```
U-Boot > setenv mmcargs 'setenv bootargs ${bootargs}
root=/dev/mmcblk3p2 rootwait rw video=mxcfb0:dev=lcd,CLAA-WVGA,if=RGB565
ip=dhcp'
```

- For i.MX 7Dual SABRE boards:

```
U-Boot > setenv mmcargs 'setenv bootargs ${bootargs}
root=/dev/mmcblk2p2 rootwait rw video=mxcfb0:dev=lcd,CLAA-WVGA,if=RGB565
ip=dhcp'
```

10. Boot up the system through rootfs in eMMC, using HDMI as display:

- For i.MX 6 boards:

```
U-Boot > setenv mmcargs 'setenv bootargs ${bootargs} root=/dev/mmcblk3p2
rootwait rw video=mxcfb0:dev=hdmi,1920x1080M@60,if=RGB24'
```

- For i.MX 7Dual SABRE boards:

```
U-Boot > setenv mmcargs 'setenv bootargs ${bootargs} root=/dev/mmcblk2p2
rootwait rw video=mxcfb0:dev=hdmi,1920x1080M@60,if=RGB24'
```

- For i.MX 8QuadMax/8QuadXPlus/8M Quad/8M Plus, the following display kernel parameters are supported:

- Pick a particular video mode for legacy FB emulation since system startup.

```
video=HDMI-A-{n}: {video_mode}
```

`n` can be **1** to the maximum number of HDMI connectors in the system. `video_mode` should be the one that the monitor on the connector supports. For example, `video=HDMI-A-1:1920x1080@60`. By default, if there is no parameter in the command line, the system uses the video mode that the monitor recommends.

- Enable or disable legacy FB emulation.

```
drm_kms_helper.fbdev_emulation=0 or 1
```

**0** to disable, **1** to enable. By default, if there is no parameter in the command line, the emulation is enabled.

- Set legacy FB emulation framebuffer's bits per pixel (bpp) parameter.

```
imxdrm.legacyfb_depth=16 or 24 or 32
```

By default, if there is no parameter in the command line, `bpp` is **16**.

To program the rootfs to MMC/SD, see [Section 4.4.2](#) or [Section 4.3](#).

#### 4.4.1.4 Flashing U-Boot on SPI-NOR from U-Boot

Flashing directly to SPI-NOR with TFTPBoot is limited to i.MX 6 SABRE-AI boards. To flash U-Boot on SPI-NOR, perform the following steps:

1. Boot from an SD card.
2. Set Jumper J3 to position: 2-3.
3. Fetch the U-Boot image with built-in SPI-NOR support. This example uses `u-boot.imx`.

```
U-Boot > tftpboot ${loadaddr} u-boot.imx
```

4. Flash the U-Boot image in SPI-NOR.

```
U-Boot > sf probe
U-Boot > sf erase 0 0x80000
U-Boot > sf write ${loadaddr} 0x400 0x7FC00
```

5. Set boot switches to boot from SPI-NOR on SABRE-AI.
  - S2-1 1
  - S2-2 1
  - S2-3 0
  - S2-4 0
  - S1-[1:10] X
6. Reboot the target board.

##### 4.4.1.4.1 Flashing an Arm Cortex-M4 image on QuadSPI

i.MX 6SoloX SABRE-SD, i.MX 7ULP EVK, and i.MX 7Dual SABRE-SD boards have the Arm Cortex-M4 processor and QuadSPI memory that can be used to flash an image to it.

#### Note:

*To enable the full features for i.MX 7ULP, burn the Arm Cortex-M4 image to QuadSPI. It is recommended to use the MFGTool script `uuu_LF6.6.3_1.0.0_images_MX7ULPEVK.zip\uuu_sd_m4.auto` to burn both BSP and Arm Cortex-M4 images.*

i.MX U-Boot provides a reference script on i.MX 7Dual SABRESD and i.MX 6SoloX SABRE-SD to flash the Arm Cortex-M4 image from the SD card. To execute the script, perform the following steps:

1. Copy the Arm Cortex-M4 image to the first VFAT partition of the boot SD card. Name the file to `m4_qspi.bin`.
2. Boot from the SD card.
3. Flash the Arm Cortex-M4 image from the SD card to the NOR flash on QuadSPI2 PortB CS0 on the i.MX 6SoloX SABRE-SD board or QuadSPI1 PortA CS0 offset 1 MB on the i.MX 7Dual SABRE-SD board.

```
U-Boot > run update_m4_from_sd
```

Alternatively, users can flash the Arm Cortex-M4 image from TFTP by performing the following steps:

1. Boot from the SD card.

2. TFTP the Arm Cortex-M4 image.

```
U-Boot > tftp ${loadaddr} m4_qspi.bin
```

3. Select the NOR flash on QuadSPI2 PortB CS0 on the i.MX 6SoloX SABRE-SD board.

```
U-Boot > sf probe 1:0
```

Select the NOR flash on QuadSPI1 PortA CS0 on the i.MX 7Dual SABRE-SD board and i.MX 7ULP EVK board.

```
U-Boot > sf probe 0:0
```

4. Flash the Arm Cortex-M4 image to the selected NOR flash. The erase size is `${filesize}`, around 64 Kbytes. This example assumes that it is 128 Kbytes.

```
U-Boot > sf erase 0x0 0x20000
U-Boot > sf write ${loadaddr} 0x0 ${filesize}
```

i.MX 7Dual SABRE-SD needs to program the Arm Cortex-M4 images to 1 MB offset, because the first 1 MB is used by the U-Boot image in QuadSPI.

```
U-Boot > sf erase 0x100000 0x20000
U-Boot > sf write ${loadaddr} 0x100000 ${filesize}
```

**Note:**

On i.MX 7Dual SABRE-SD, the Arm Cortex-M4 image on QuadSPI is supported only when the U-Boot image is built by the target `mx7dsabresd_qspi1_defconfig` booted by U-Boot from QuadSPI.

The default U-Boot for the i.MX 7Dual SABRESD board uses the Cortex-M4 image from the SD card and runs it on OCRAM.

On i.MX 7ULP EVK, the Arm Cortex-M4 image needs to be programmed. Otherwise, it will not boot.

#### 4.4.1.5 Flashing U-Boot on Parallel NOR from U-Boot

Flashing directly to Parallel NOR with TFTPBoot is limited to i.MX 6 SABRE-AI boards. To flash U-Boot on Parallel NOR, perform the following steps:

1. Check the jumper J3, should not between pins 2 and 3.
2. Update the SD U-Boot with EIM NOR version. For details on commands, see [Section 4.3.4](#). Then boot from the SD card.
3. TFTP the U-Boot image.

```
tftpboot ${loadaddr} u-boot.imx
```

4. Flash the U-Boot image.

```
cp.b ${loadaddr} 0x08001000 ${filesize}
```

5. Change boot switches and reboot.

```
S2 all 0 S1-6 1 others 0
```

6. By default, rootfs is mounted on NFS.

#### 4.4.2 Using an i.MX board as the host server to create a rootfs

Linux OS provides multiple methods to program images to the storage device. This section describes how to use the i.MX platform as a Linux host server to create the rootfs on an MMC/SD card or the SATA device. The following example is for an SD card. The device file node name needs to be changed for a SATA device.

1. Boot from NFS or other storage. Determine your SD card device ID. It could be `mmcblk*` or `sd*`. (The index is determined by the USDHC controller index.) Check the partition information with the command:

```
$ cat /proc/partitions
```

2. To create a partition on the MMC/SD card, use the `fdisk` command (requires root privileges) in the Linux console:

```
root@ ~$ sudo fdisk /dev/$SD
```

Replace `$SD` above with the name of your device.

3. If this is a new SD card, you may get the following message:

```
The device contains neither a valid DOS partition table, nor Sun, SGI or OSF
disk label
Building a new DOS disklabel. Changes will remain in memory only,
until you decide to write them. After that the previous content
won't be recoverable.
The number of cylinders for this disk is set to 124368.
There is nothing wrong with that, but this is larger than 1024,
and could in certain setups cause problems with:
1) software that runs at boot time (e.g., old versions of LILO)
2) booting and partitioning software from other OSs
   (e.g., DOS FDISK, OS/2 FDISK)
```

The usual prompt and commands to partition the card are as follows. Text in boldface indicates what the user types.

```
Command (m for help): p
Disk /dev/sdd: 3965 MB, 3965190144 bytes
4 heads, 32 sectors/track, 60504 cylinders, total 7744512 sectors
Units = sectors of 1 * 512 = 512 bytes
Sector size (logical/physical): 512 bytes / 512 bytes
I/O size (minimum/optimal): 512 bytes / 512 bytes
Disk identifier: 0x00080bff
   Device Boot      Start         End      Blocks   Id  System
```

4. As described in [Section 4.6](#), the `rootfs` partition should be located after the kernel image. The first 0x800000 bytes can be reserved for MBR, bootloader, and kernel sections. From the log shown above, the `Units` of the current MMC/SD card is 32768 bytes. The beginning cylinder of the first partition can be set to "0x300000/32768 = 96." The last cylinder can be set according to the `rootfs` size. Create a new partition by typing the letters in bold:

```
Command (m for help): n
  e extended
  p primary partition (1-4)
Select (default p): p
Partition number (1-4): 1
First cylinder (1-124368, default 1): 96
Last cylinder or +size or +sizeM or +sizeK (96-124368, default 124368): Using
default value 124368
Command (m for help): w
The partition table has been altered!
Calling ioctl() to re-read $SD partition table
```

5. Check the partitions (see above) to determine the name of the partition. `$PARTITION` is used here to indicate the partition to be formatted. Format the MMC/SD partitions as `ext3` or `ext4` type. For example, to use `ext3`:

```
root@ ~$ mkfs.ext3 /dev/$PARTITION
mke2fs 1.42 (29-Nov-2011)
Filesystem label=
```

```

OS type: Linux
Block size=4096 (log=2)
Fragment size=4096 (log=2)
248992 inodes, 994184 blocks
49709 blocks (5.00%) reserved for the super user
First data block=0
Maximum filesystem blocks=1019215872
31 block groups
32768 blocks per group, 32768 fragments per group
8032 inodes per group
Superblock backups stored on blocks:
    32768, 98304, 163840, 229376, 294912, 819200, 884736
Writing inode tables: done
Creating journal (16384 blocks): done
Writing superblocks and filesystem accounting information: done
This filesystem will be automatically checked every 20 mounts or
180 days, whichever comes first. Use tune2fs -c or -i to override.

```

6. Copy the rootfs contents to the MMC/SD card. The name may vary from the one used below. Check the directory for the rootfs desired. (Copy the \*.ext2 to NFS rootfs).

```

mkdir /mnt/tmpmnt
mount -t ext3 -o loop /imx-image-multimedia.ext3 /mnt/tmpmnt
cd /mnt
mkdir mmcblk0p1
mount -t ext3 /dev/$PARTITION /mnt/mmcblk0p1
cp -af /mnt/tmpmnt/* /mnt/mmcblk0p1/
umount /mnt/mmcblk0p1
umount /mnt/tmpmnt

```

7. Type `sync` to write the contents to MMC/SD.
8. Type `poweroff` to power down the system. Follow the instructions in [Section 4.7](#) to boot the image from the MMC/SD card.

**Note:** By default, v2013.04 and later versions of U-Boot support loading the kernel image and DTB file from the SD/MMC vfat partition by using the `fatload` command. To use this feature, perform the following steps:

1. Format the first partition (for example 50 MB) of the SD/MMC card with vfat filesystem.
2. Copy `zImage` and the DTB file into the VFAT partition after you mount the VFAT partition into your host computer.
3. Make sure that the `zImage` and DTB filename are synchronized with the filename pointed to by the U-Boot environment variables: `fdtfile` and `image`. Use the `print` command under U-Boot to display these two environment variables. For example:

```
print fdtfile image
```

4. U-Boot loads the kernel image and the DTB file from your VFAT partition automatically when you boot from the SD/MMC card.

The following is an example to format the first partition to a 50 MB vfat filesystem and format the second partition to an ext4 filesystem:

```

~$ fdisk /dev/sdb
Command (m for help): n
Partition type:
   p   primary (0 primary, 0 extended, 4 free)
   e   extended
Select (default p): p
Partition number (1-4, default 1): 1
First sector (2048-30318591, default 2048): 4096

```

```
Last sector, +sectors or +size{K,M,G} (4096-30318591, default 30318591): +50M
Command (m for help): p
Disk /dev/sdb: 15.5 GB, 15523119104 bytes
64 heads, 32 sectors/track, 14804 cylinders, total 30318592 sectors
Units = sectors of 1 * 512 = 512 bytes
Sector size (logical/physical): 512 bytes / 512 bytes
I/O size (minimum/optimal): 512 bytes / 512 bytes
Disk identifier: 0x3302445d
   Device Boot      Start         End      Blocks   Id  System
/dev/sdb1            4096     106495       51200    83   Linux
Command (m for help): n
Partition type:
   p   primary (1 primary, 0 extended, 3 free)
   e   extended
Select (default p): p
Partition number (1-4, default 2): 2
First sector (2048-30318591, default 2048): 106496
Last sector, +sectors or +size{K,M,G} (106496-30318591, default 30318591):
Using default value 30318591
Command (m for help): p
Disk /dev/sdb: 15.5 GB, 15523119104 bytes
64 heads, 32 sectors/track, 14804 cylinders, total 30318592 sectors
Units = sectors of 1 * 512 = 512 bytes
Sector size (logical/physical): 512 bytes / 512 bytes
I/O size (minimum/optimal): 512 bytes / 512 bytes
Disk identifier: 0x3302445d
   Device Boot      Start         End      Blocks   Id  System
/dev/sdb1            4096     106495       51200    83   Linux
/dev/sdb2           106496     30318591    15106048    83   Linux
Command (m for help): w
The partition table has been altered!
Calling ioctl() to re-read partition table.
Syncing disks.
~$ mkfs.vfat /dev/mmcb1k0p1
~$ mkfs.ext4 /dev/mmcb1k0p2
```

## 4.5 How to boot the i.MX boards

When U-Boot is loaded onto one of the devices that support booting, the DIP switches can be used to boot from that device. The boot modes of the i.MX boards are controlled by the boot configuration DIP switches on the board. For help with locating the boot configuration switches, see the quick start guide for the specific board as listed under References above.

The following sections list basic boot setup configurations. The tables below represent the DIP switch settings for the switch blocks on the specified boards. An X means that particular switch setting does not affect this action.

### 4.5.1 Booting from an SD card in slot SD1

The following table shows the DIP switch settings for booting from the SD card slot labeled SD1 on the i.MX 7Dual SABRE-SD boards.

Table 2. Booting from SD1 on i.MX 7Dual SABRE-SD

Switch	D1	D2	D3	D4	D5	D6	D7	D8
SW2	OFF	OFF	ON	OFF	OFF	OFF	OFF	OFF
SW3	ON	OFF	-	-	-	-	-	-

The following table shows the DIP switch settings for booting from the SD card slot labeled SD1 on the i.MX 7ULP EVK boards.

**Table 3. Booting from SD1 on i.MX 7ULP EVK**

Switch	D1	D2	D3	D4
SW1	ON	OFF	OFF	ON

The following table shows the bootcfg pin settings for booting from the SD card slot labeled SD1 on the i.MX 8QuadMax MEK boards.

**Table 4. Booting from SD1 on i.MX 8QuadMax MEK**

Switch	D1	D2	D3	D4	D5	D6	D7	D8
SW2	OFF	OFF	ON	ON	OFF	OFF	-	-

The following table shows the bootcfg pin settings for booting from the SD card slot labeled SD1 on the i.MX 8QuadXPlus MEK boards.

**Note:** This is the same setting for the i.MX 8DualX MEK and i.MX 8DXL EVK boards.

**Table 5. Booting from SD1 on i.MX 8QuadXPlus MEK**

Switch	D1	D2	D3	D4
SW2	ON	ON	OFF	OFF

#### 4.5.2 Booting from an SD card in slot SD2

The SD card slot that is labeled SD2 indicates that this slot is connected to the uSDHC pin SD2 on the processor. Most boards label this slot as SD2. This slot is referred to as SD2 in this document.

The following table shows the DIP switch settings for booting from the SD card slot labeled SD2 and J500 on the i.MX 6 SABRE-SD boards. The SD2 card slot is located beside the LVDS1 connection on the back of the board.

**Table 6. Booting from SD2 (J500) on i.MX 6 SABRE-SD**

Switch	D1	D2	D3	D4	D5	D6	D7	D8
SW6	ON	OFF	OFF	OFF	OFF	OFF	ON	OFF

The i.MX 6UltraLite EVK board or i.MX 6ULL EVK board has one TF card slot on the CPU board. This slot uses the USDHC2 controller. The following table shows the DIP switch settings for booting from the TF slot.

**Table 7. Booting from TF on i.MX 6UltraLite EVK and i.MX 6ULL EVK**

Switch	D1	D2	D3	D4
SW601	OFF	OFF	ON	OFF
SW602	ON	OFF	-	-

The i.MX 8M Quad EVK board has one TF card slot. This slot uses the USDHC2 controller. The following table shows the DIP switch settings for booting from the TF slot.

**Table 8. Booting from TF on i.MX 8M Quad EVK**

Switch	D1	D2	D3	D4
SW801	ON	ON	OFF	OFF
SW802	ON	OFF	-	-



The i.MX 8M Mini EVK board has one TF card slot. This slot uses the USDHC2 controller. The following table shows the DIP switch settings for booting from the TF slot.

**Table 9. Booting from TF on i.MX 8M Mini EVK**

Switch	D1	D2	D3	D4	D5	D6	D7	D8
SW1101	OFF	ON	OFF	OFF	OFF	ON	ON	OFF
SW1102	OFF	OFF	ON	ON	OFF	ON	OFF	OFF

The i.MX 8M Nano EVK board has one TF card slot. This slot uses the USDHC2 controller. The following table shows the DIP switch settings for booting from the TF slot.

**Table 10. Booting from TF on i.MX 8M Nano EVK**

Switch	D1	D2	D3	D4
SW1101	ON	ON	OFF	OFF

The i.MX 8M Plus EVK board has one TF card slot. This slot uses the USDHC2 controller. The following table shows the DIP switch settings for booting from the TF slot.

**Table 11. Booting from TF on i.MX 8M Plus EVK**

Switch	D1	D2	D3	D4
SW4	OFF	OFF	ON	ON

The following table shows the DIP switch settings for booting from the USDHC2 slot.

**Table 12. Booting from USDHC2 on i.MX 93 11x11 EVK and i.MX 91P 11x11 EVK**

Switch	D1	D2	D3	D4
SW1301	OFF	ON	OFF	OFF

**Table 13. Booting from USDHC2 on i.MX 93 9x9 QSB and i.MX 91P 9x9 QSB**

Switch	D1	D2	D3	D4
SW61301	OFF	OFF	ON	ON

**Table 14. Booting from USDHC2 on i.MX 95 19x19 EVK**

Switch	D1	D2	D3	D4
SW7	ON	OFF	ON	ON

### 4.5.3 Booting from an SD card in slot SD3

The SD card slot that is labeled SD3 indicates that this slot is connected to the uSDHC pin SD3 on the processor. Most boards label this slot as SD3. This slot is referred to as SD3 in this document.

The following table shows the DIP switch settings to boot from an SD card in slot SD3 on i.MX 6 SABRE-AI boards.

**Table 15. Booting from an SD card in slot SD3 on i.MX 6 SABRE-AI**

Switch	D1	D2	D3	D4	D5	D6	D7	D8	D9	D10
S1	X	X	X	OFF	ON	X	X	X	X	X

**Table 15. Booting from an SD card in slot SD3 on i.MX 6 SABRE-AI...continued**

Switch	D1	D2	D3	D4	D5	D6	D7	D8	D9	D10
<b>S2</b>	X	OFF	ON	OFF	-	-	-	-	-	-
<b>S3</b>	OFF	OFF	ON	OFF	-	-	-	-	-	-

The following table shows the DIP switch settings to boot from an SD card in slot SD3 on i.MX 6SoloX SABRE-AI boards.

**Table 16. Booting from an MMC card in Slot SD3 on i.MX 6SoloX SABRE-AI**

Switch	D1	D2	D3	D4	D5	D6	D7	D8
<b>S4</b>	OFF	ON	OFF	X	OFF	OFF	ON	OFF
<b>S3</b>	X	OFF	OFF	OFF	ON	ON	OFF	OFF
<b>S1</b>	OFF	OFF	ON	OFF	-	-	-	-

The following table shows the DIP switch settings for booting from SD3, also labeled as J507. The SD3 slot is located between the HDMI and UART ports.

**Table 17. Booting from an SD card in slot SD3 on i.MX 6 SABRE-SD**

Switch	D1	D2	D3	D4	D5	D6	D7	D8
<b>SW6</b>	OFF	ON	OFF	OFF	OFF	OFF	ON	OFF

#### 4.5.4 Booting from an SD card in slot SD4

The following table describes the dip switch settings for booting from an SD card in slot SD4.

The SD4 slot is on the center of the edge of the SoloX board.

**Table 18. Booting from an SD card in slot SD4 on i.MX 6SoloX SABRE-SD**

Switch	D1	D2	D3	D4	D5	D6	D7	D8
SW10	OFF	OFF	OFF	OFF	OFF	OFF	OFF	OFF
SW11	OFF	OFF	ON	ON	ON	OFF	OFF	OFF
SW12	OFF	ON	OFF	OFF	OFF	OFF	OFF	OFF

**Table 19. Booting from an MMC card in slot SD4 on i.MX 6SoloX SABRE-SD**

Switch	D1	D2	D3	D4	D5	D6	D7	D8
SW10	OFF	OFF	OFF	OFF	OFF	OFF	OFF	OFF
SW11	OFF	OFF	ON	ON	ON	OFF	OFF	OFF
SW12	OFF	ON	ON	OFF	OFF	OFF	OFF	OFF

#### 4.5.5 Booting from eMMC

eMMC 4.4 is a chip permanently attached to the board that uses the SD4 pin connections from the i.MX 6 processor. For more information on switch settings, see table "MMC/eMMC Boot Fusemap" in the IC reference manual.

The following table shows the boot switch settings to boot from eMMC4.4 (SDIN5C2-8G) on i.MX 6 SABRE-SD boards.

Table 20. Booting from eMMC on i.MX 6 SABRE-SD

Switch	D1	D2	D3	D4	D5	D6	D7	D8
SW6	ON	ON	OFF	ON	OFF	ON	ON	OFF

i.MX 7Dual is different from i.MX 6. The eMMC uses the SD3 pin connections from the i.MX 7Dual processor.

Table 21. Booting from eMMC on i.MX 7Dual SABRE-SD

Switch	D1	D2	D3	D4	D5	D6	D7	D8
SW2	OFF	ON	OFF	ON	OFF	OFF	OFF	OFF
SW3	ON	OFF	-	-	-	-	-	-

The following table shows the boot switch settings to boot from eMMC4.4 on the i.MX 7ULP EVK boards.

Table 22. Booting from eMMC on i.MX 7ULP EVK

Switch	D1	D2	D3	D4
SW1	ON	OFF	OFF	OFF

The following table shows the boot switch settings to boot from eMMC5.0 on the i.MX 8QuadMax MEK boards.

Table 23. Booting from eMMC on i.MX 8QuadMax MEK

Switch	D1	D2	D3	D4	D5	D6	D7	D8
SW2	OFF	OFF	OFF	ON	OFF	OFF	-	-

The following table shows the boot switch settings to boot from eMMC5.0 on the i.MX 8QuadXPlus MEK boards.

**Note:** This is the same setting for the i.MX 8DualX MEK and i.MX 8DXL EVK boards, except that 8DXL EVK uses SW1.

Table 24. Booting from eMMC on i.MX 8QuadXPlus MEK

Switch	D1	D2	D3	D4
SW2	OFF	ON	OFF	OFF

The following table shows the boot switch settings to boot from eMMC5.0 on the i.MX 8M Quad EVK boards.

Table 25. Booting from eMMC on i.MX 8M Quad EVK

Switch	D1	D2	D3	D4
SW801	OFF	OFF	ON	OFF

The following table shows the boot switch settings to boot from eMMC5.1 on the i.MX 8M Mini EVK boards.

Table 26. Booting from eMMC on i.MX 8M Mini EVK

Switch	D1	D2	D3	D4	D5	D6	D7	D8
SW1101	OFF	ON	ON	ON	OFF	OFF	ON	OFF
SW1102	OFF	OFF	OFF	OFF	ON	OFF	ON	OFF

The following table shows the boot switch settings to boot from eMMC5.1 on the i.MX 8M Nano EVK boards.

**Table 27. Booting from eMMC on i.MX 8M Nano EVK**

Switch	D1	D2	D3	D4
SW1101	OFF	ON	OFF	OFF

The following table shows the boot switch settings to boot from eMMC5.1 on the i.MX 8M Plus EVK boards.

**Table 28. Booting from eMMC on i.MX 8M Plus EVK**

Switch	D1	D2	D3	D4
SW4	OFF	OFF	OFF	ON

The following table lists the boot switch settings to boot from eMMC5.1 on the i.MX 8ULP EVK.

**Table 29. Singleboot booting from eMMC on i.MX 8ULP EVK**

Switch	D1	D2	D3	D4	D5	D6	D7	D8
SW5	OFF	OFF	OFF	OFF	OFF	OFF	OFF	ON

**Table 30. Dualboot booting from eMMC for A35 on i.MX 8ULP EVK**

Switch	D1	D2	D3	D4	D5	D6	D7	D8
SW5	OFF	ON	OFF	OFF	OFF	OFF	OFF	ON

**Table 31. Booting from eMMC on i.MX 93 11x11 EVK and i.MX 91P 11x11 EVK**

Switch	D1	D2	D3	D4
SW1301	OFF	OFF	OFF	OFF

**Table 32. Booting from eMMC on i.MX 93 9x9 QSB and i.MX 91P 9x9 QSB**

Switch	D1	D2	D3	D4
SW601	OFF	OFF	ON	OFF

**Table 33. Booting from eMMC on i.MX 95 19x19 EVK**

Switch	D1	D2	D3	D4
SW7	ON	OFF	ON	OFF

### 4.5.6 Booting from SATA

The following switch settings enable booting from SATA.

SATA booting is supported only by the i.MX 6Quad/6QuadPlus SABRE boards.

**Table 34. Booting from SATA on i.MX 6 SABRE-SD**

Switch	D1	D2	D3	D4	D5	D6	D7	D8
SW6	OFF	OFF	OFF	OFF	OFF	ON	OFF	OFF

### 4.5.7 Booting from NAND

The following table shows the DIP switch settings needed to boot from NAND on i.MX 6 SABRE-AI boards.

**Table 35. Booting from NAND on i.MX 6 SABRE-AI**

Switch	D1	D2	D3	D4	D5	D6	D7	D8	D9	D10
S1	OFF	OFF	OFF	ON	OFF	OFF	OFF	OFF	OFF	OFF
S2	OFF	OFF	OFF	ON	-	-	-	-	-	-
S3	OFF	OFF	ON	OFF	-	-	-	-	-	-

The following table shows the DIP switch settings needed to boot from NAND for i.MX 7Dual SABRE-SD boards.

**Table 36. Booting from NAND on i.MX 7Dual SABRE-SD**

Switch	D1	D2	D3	D4	D5	D6	D7	D8	D9	D10
S2	OFF	ON	ON	X	X	X	X	OFF	-	-
S3	ON	OFF	X	X	X	X	X	X	-	-

The following table shows the DIP switch settings needed to boot from NAND for i.MX 8M Mini DDR4 EVK boards.

**Table 37. Booting from NAND on i.MX 8M Mini DDR4 EVK**

Switch	D1	D2	D3	D4	D5	D6	D7	D8	D9	D10
SW1101	OFF	ON	OFF	OFF	OFF	OFF	OFF	ON	-	-
SW1102	OFF	OFF	OFF	ON	ON	ON	ON	OFF	-	-

**Table 38. Booting from FlexSPI NAND on i.MX 91P 9x9 QSB**

Switch	D1	D2	D3	D4
SW601	OFF	ON	OFF	ON

### 4.5.8 Booting from SPI-NOR

Enable booting from SPI NOR on i.MX 6 SABRE-AI boards by placing a jumper on J3 between pins 2 and 3.

**Table 39. Booting from SPI-NOR on i.MX 6 SABRE-AI**

Switch	D1	D2	D3	D4	D5	D6	D7	D8	D9	D10
S1	X	X	X	X	X	X	X	X	X	X
S2	ON	ON	OFF	OFF	OFF	OFF	OFF	OFF	OFF	OFF
S3	OFF	OFF	ON	OFF	-	-	-	-	-	-

### 4.5.9 Booting from EIM (Parallel) NOR

The following table shows the DIP switch settings to boot from NOR.

**Table 40. Booting from EIM NOR on i.MX 6 SABRE-AI**

Switch	D1	D2	D3	D4	D5	D6	D7	D8	D9	D10
S1	X	X	X	OFF	OFF	ON	X	X	X	X
S2	X	OFF	OFF	OFF	-	-	-	-	-	-
S3	OFF	OFF	ON	OFF	-	-	-	-	-	-

**Note:**

SPI and EIM NOR have pin conflicts on i.MX 6 SABRE-AI boards. Neither can be used for the same configuration. The default U-Boot configuration is set to SPI NOR.

**4.5.10 Booting from QuadSPI or FlexSPI**

The following tables list the DIP switch settings for booting from QuadSPI.

**Table 41. Booting from QuadSPI on i.MX 6SoloX SABRE-SD**

Switch	D1	D2	D3	D4	D5	D6	D7	D8
SW10	OFF	OFF	OFF	OFF	OFF	OFF	OFF	OFF
SW11	OFF	OFF	OFF	OFF	OFF	OFF	OFF	OFF
SW12	OFF	OFF	OFF	ON	ON	OFF	OFF	OFF

**Table 42. Booting from QuadSPI on i.MX 6SoloX SABRE-AI**

Switch	D1	D2	D3	D4	D5	D6	D7	D8
SW4	OFF	OFF	OFF	OFF	ON	OFF	OFF	OFF
SW3	OFF	OFF	OFF	OFF	OFF	OFF	OFF	OFF
SW1	OFF	OFF	ON	OFF	-	-	-	-

**Table 43. Booting from QuadSPI on i.MX 7Dual SABRE-SD**

Switch	D1	D2	D3	D4	D5	D6	D7	D8
SW2	ON	OFF	OFF	OFF	OFF	OFF	OFF	OFF
SW3	ON	OFF	-	-	-	-	-	-

**Table 44. Booting from QuadSPI on i.MX 6UltraLite EVK and i.MX 6ULL EVK**

Switch	D1	D2	D3	D4
SW601	OFF	OFF	OFF	OFF
SW602	ON	OFF	-	-

**Table 45. Booting from FlexSPI on i.MX 8QuadMax MEK**

Switch	D1	D2	D3	D4	D5	D6	D7	D8
SW2	OFF	OFF	OFF	ON	ON	OFF	-	-

Table 46. Booting from FlexSPI on i.MX 8QuadXPlus MEK

Switch	D1	D2	D3	D4
SW2	OFF	ON	ON	OFF

Table 47. Booting from FlexSPI on i.MX 8M Mini LPDDR4 EVK

Switch	D1	D2	D3	D4	D5	D6	D7	D8
SW1101	OFF	ON	OFF	OFF	OFF	OFF	OFF	OFF
SW1102	OFF	ON	OFF	OFF	OFF	OFF	OFF	ON

Table 48. Booting from QuadSPI on i.MX Nano EVK

Switch	D1	D2	D3	D4
SW601	OFF	OFF	OFF	OFF
SW602	ON	OFF	-	-

Table 49. Booting from QuadSPI on i.MX 8M Plus EVK

Switch	D1	D2	D3	D4
SW4	OFF	ON	ON	OFF

Table 50. Singleboot booting from FlexSPI NOR on i.MX 8ULP EVK

Switch	D1	D2	D3	D4	D5	D6	D7	D8
SW5	OFF	OFF	OFF	OFF	OFF	ON	OFF	ON

Table 51. Dualboot booting from FlexSPI for A35 on i.MX 8ULP EVK

Switch	D1	D2	D3	D4	D5	D6	D7	D8
SW5	OFF	ON	OFF	OFF	OFF	ON	OFF	ON

Table 52. Booting from FlexSPI NOR on i.MX 95 19x19 EVK

Switch	D1	D2	D3	D4
SW7	ON	ON	OFF	OFF

#### 4.5.11 Serial download mode for the Manufacturing Tool

No dedicated boot DIP switches are reserved for serial download mode on i.MX 6 SABRE-SD. There are various ways to enter serial download mode. One way is to set the boot mode to boot from SD slot SD3 (set SW6 DIP switches 2 and 7 to **on**, and the rest are **off**). Do not insert the SD card into slot SD3, and power on the board. After the message "HID Compliant device" is displayed, the board enters serial download mode. Then insert the SD card into SD slot SD3. Another way to do this is to configure an invalid boot switch setting, such as setting all the DIP switches of SW6 to off.

The following table shows the boot switch settings for i.MX 6 SABRE-AI boards, which are used to enter serial download mode for the Manufacturing Tool. If the boot image in the boot media is not validated, the system also enters the serial download mode.

**Table 53. Setup for the Manufacturing Tool on i.MX 6 SABRE-AI**

Switch	D1	D2	D3	D4
S3	OFF	ON	OFF	OFF

**Table 54. Setup for the Manufacturing Tool on i.MX 7Dual SABRE-SD**

Switch	D1	D2	D3	D4
S3	OFF	ON	-	-

**Table 55. Setup for Manufacturing Tool on i.MX 6UltraLite EVK and i.MX 6ULL EVK**

Switch	D1	D2
SW602	OFF	ON

**Table 56. Setup for Manufacturing Tool on i.MX 7ULP EVK**

Switch	D1	D2	D3	D4
SW1	OFF	ON	-	-

**Table 57. Setup for Manufacturing Tool on i.MX 8M Quad EVK**

Switch	D1	D2
SW802	OFF	ON

**Table 58. Setup for Manufacturing Tool on i.MX 8M Plus EVK**

Switch	D1	D2	D3	D4
SW4	OFF	OFF	ON	OFF

**Table 59. Setup for Manufacturing Tool on i.MX 8M Mini EVK**

Switch	D1	D2	D3	D4	D5	D6	D7	D8
SW1101	ON	OFF	X	X	X	X	X	X
SW1102	X	X	X	X	X	X	X	X

**Table 60. Setup for Manufacturing Tool on i.MX 8M Nano EVK**

Switch	D1	D2	D3	D4
SW1101	ON	OFF	OFF	OFF



Table 61. Setup for Manufacturing Tool on i.MX 8QuadMax MEK

Switch	D1	D2	D3	D4	D5	D6
SW2	OFF	OFF	ON	OFF	OFF	OFF

**Note:**

The following settings are same for the i.MX 8DualX MEK and i.MX 8DXL EVK boards (8DXL EVK uses SW1).

Table 62. Setup for Manufacturing Tool on i.MX 8QuadXPlus MEK

Switch	D1	D2	D3	D4
SW2	ON	OFF	OFF	OFF

Table 63. Setup for Manufacturing Tool on i.MX 8ULP EVK

Switch	D1	D2	D3	D4	D5	D6	D7	D8
SW2	OFF	OFF	OFF	OFF	OFF	OFF	ON	OFF

Table 64. Setup for Manufacturing Tool on i.MX 93 11x11 EVK and i.MX 91P 11x11 EVK

Switch	D1	D2	D3	D4
SW1301	ON	ON	OFF	OFF

Table 65. Setup for Manufacturing Tool on i.MX 93 9x9 QSB and i.MX 91P 9x9 QSB

Switch	D1	D2	D3	D4
SW601	OFF	OFF	OFF	ON

Table 66. Setup for Manufacturing Tool on i.MX 95 19x19 EVK

Switch	D1	D2	D3	D4
SW7	ON	OFF	OFF	ON

**Note:**

If the SD card with bootable image is plugged in SD2 (baseboard), ROM will not fall back into the serial download mode.

**4.5.12 How to build U-Boot and Kernel in standalone environment**

To build U-Boot and Kernel in a standalone environment, perform the following steps.

First, generate an SDK, which includes the tools, toolchain, and small rootfs to compile against to put on the host machine.

- Generate an SDK from the Yocto Project build environment with the following command. To set up the Yocto Project build environment, follow the steps in the *i.MX Yocto Project User's Guide* (IMXLXOCTOUG). In the following command, set `Target-Machine` to the machine you are building for. The `populate_sdk`

generates a script file that sets up a standalone environment without Yocto Project. This SDK should be updated for each release to pick up the latest headers, toolchain, and tools from the current release.

```
DISTRO=fsl-imx-fb MACHINE=Target-Machine bitbake core-image-minimal -c
populate_sdk
```

**Note:**

*If the building process is interrupted, modify `conf/local.conf` to comment out the line:*

*`PACKAGE_CLASSES = "package_deb", and then execute the populate_sdk command again.`*

- From the build directory, the `bitbake` was run in, copy the `sh` file in `tmp/deploy/sdk` to the host machine to build on and execute the script to install the SDK. The default location is in `/opt`, but it can be placed anywhere on the host machine.

On the host machine, the following are the steps to build U-Boot and Kernel.

**Toolchain Configuration:**

- For i.MX 6 and i.MX 7 builds on the host machine, set the environment with the following command before building.

```
source /opt/fsl-imx-fb/6.6-nanbiel/environment-setup-cortexa9hf-neon-poky-linux-gnueab
export ARCH=arm
```

- For i.MX 8 and i.MX 9 builds on the host machine, set the environment with the following command before building.

```
source /opt/fsl-imx-xwayland/6.6-nanbiel/environment-setup-aarch64-poky-linux
export ARCH=arm64
```

**U-Boot:**

Download source by cloning with:

```
git clone https://github.com/nxp-imx/uboot-imx -b lf_v2023.04
cd uboot-imx
```

- To build an i.MX 6 or i.MX 7 U-Boot in the standalone environment, find the configuration for the target boot. In the following example, i.MX 6ULL is the target.

```
make clean
make mx6ull_14x14_evk_defconfig
make
```

- To build an i.MX 8 U-Boot in the standalone environment, find the configuration for the target boot. In the following example, i.MX 8QuadMax MEK board is the target and it runs on the Arm Cortex-A53 core by default. SPL image (`u-boot-spl.bin`) is also generated with the default `defconfig`. It is needed when booting with OP-TEE image.

```
make distclean
make imx8qm_mek_defconfig
make
```

For i.MX 8QuadXPlus MEK and i.MX 8DualX board:

```
make distclean
make imx8qxp_mek_defconfig
make
```

For i.MX 8DXL EVK board:

```
make distclean
make imx8dxl_evk_defconfig
```

```
make
```

- For i.MX 8M Quad EVK:

```
make distclean
make imx8mq_evk_defconfig
make
```

- For i.MX 8M LPDDR4 EVK:

```
make distclean
make imx8mm_evk_defconfig
make
```

- For i.MX 8M DDR4 EVK:

```
make distclean
make imx8mm_ddr4_evk_defconfig
make
```

- For i.MX 8M Plus LPDDR4 EVK board:

```
make distclean
make imx8mp_evk_defconfig
make
```

- For i.MX 8ULP EVK board:

```
make distclean
make imx8ulp_evk_defconfig
make
```

- For i.MX 93 11x11 EVK board:

```
make distclean
make imx93_11x11_evk_defconfig
make
```

- For i.MX 93 9x9 QSB board:

```
make distclean
make imx93_9x9_qsb_defconfig
make
```

- For i.MX 91P 11x11 EVK board:

```
make distclean
make imx91p_11x11_evk_defconfig
make
```

- For i.MX 91P 9x9 QSB board:

```
make distclean
make imx91p_9x9_qsb_defconfig
make
```

- For i.MX 95 19x19 EVK board:

```
make distclean
make imx95_19x19_evk_defconfig
make
```

**Kernel:**

Download source by cloning with:

```
git clone https://github.com/nxp-imx/linux-imx -b lf-6.6.y
cd linux-imx
```

- To build the kernel in the standalone environment for i.MX 6 and i.MX 7, execute the following commands:

```
make imx_v7_defconfig
make
```

- To build the kernel in the standalone environment for i.MX 8 and i.MX 9, execute the following commands:

```
make imx_v8_defconfig
make
```

#### Note:

Users need to modify configurations for fused parts. For example, the i.MX 6UltraLite has four parts, G0, G1, G2, and G3.

The fused modules are as follows:

- G0: TSC, ADC2, FLEXCAN1, FLEXCAN2, FREQ\_MON, TEMP\_MON, VOLT\_MONLCDIF, CSI, ENET2, CAAM, USB\_OTG2, SAI23, BEE, UART5678, PWM5678, ECSPi34, I2C34, GPT2, and EPIT2.
- G1: TSC, ADC2, FLEXCAN2, FREQ\_MON, TEMP\_MON, VOLT\_MON, LCDIF, CSI, ENET2, and BEE.
- G2: FREQ\_MON, TEMP\_MON, VOLT\_MON, and BEE.
- G3: No fused module.

U-Boot configuration changes:

G0:

```
/* #define CONFIG_VIDEO */
#define CONFIG_FEC_ENET_DEV 0
/* #define CONFIG_CMD_BEE */
#define CONFIG_USB_MAX_CONTROLLER_COUNT 1
```

G1:

```
/* #define CONFIG_VIDEO */
#define CONFIG_FEC_ENET_DEV 0
/* #define CONFIG_CMD_BEE */
```

G2:

```
/* #define CONFIG_CMD_BEE */
```

G3: No change.

#### 4.5.13 How to build imx-boot image by using imx-mkimage

For i.MX 8QuadMax, to build imx-boot image by using imx-mkimage, perform the following steps:

1. Copy `u-boot.bin` from `u-boot/u-boot.bin` to `imx-mkimage/iMX8QM/`.
2. Copy `scfw_tcm.bin` from SCFW porting kit to `imx-mkimage/iMX8QM/`.
3. Copy `bl31.bin` from Arm Trusted Firmware (`imx-atf`) to `imx-mkimage/iMX8QM/`.
4. Copy the SECO firmware container image (`mx8qmb0-ahab-container.img`) to `imx-mkimage/iMX8QM/`.

5. Run `make SOC=iMX8QM flash` to generate `flash.bin`.
6. If using OP-TEE, copy `tee.bin` to `imx-mkimage/iMX8QM/` and copy `u-boot/spl/u-boot-spl.bin` to `imx-mkimage/iMX8QM/`. Run `make SOC=iMX8QM flash_spl` to generate `flash.bin`.

For i.MX 8QuadXPlus, to build `imx-boot` image by using `imx-mkimage`, perform the following steps:

1. Copy `u-boot.bin` from `u-boot/u-boot.bin` to `imx-mkimage/iMX8QX/`.
2. Copy `scfw_tcm.bin` from SCFW porting kit to `imx-mkimage/iMX8QX/`.
3. Copy `bl31.bin` from Arm Trusted Firmware (`imx-atf`) to `imx-mkimage/iMX8QX/`.
4. Copy the SECO firmware container images (`mx8qxp0-ahab-container.img` and `mx8qxp0-ahab-container.img`) to `imx-mkimage/iMX8QM/`.
5. Run `make SOC=iMX8QX flash` to generate `flash.bin` for i.MX 8QuadXPlus B0, and run `make SOC=iMX8QX REV=C0 flash` to generate `flash.bin` for i.MX 8QuadXPlus C0.
6. If using OP-TEE, copy `tee.bin` to `imx-mkimage/iMX8QX/` and copy `u-boot/spl/u-boot-spl.bin` to `imx-mkimage/iMX8QX/`. Run `make SOC=iMX8QX flash_spl` to generate `flash.bin`.

For i.MX 8DXL, to build `imx-boot` image by using `imx-mkimage`, perform the following steps:

1. Copy `u-boot.bin` from `u-boot/u-boot.bin` to `imx-mkimage/iMX8DXL/`.
2. Copy `scfw_tcm.bin` from SCFW porting kit to `imx-mkimage/iMX8DXL/`.
3. Copy `bl31.bin` from Arm Trusted Firmware (`imx-atf`) to `imx-mkimage/iMX8DXL/`.
4. Copy the image of SECO firmware container (`mx8dxl0-ahab-container.img` and `mx8dxl0-ahab-container.img`) to `imx-mkimage/iMX8DXL/`.
5. Run `make SOC=iMX8DXL flash` to generate `flash.bin` for i.MX 8DXL A1, and run `make SOC=iMX8DXL REV=B0 flash` to generate `flash.bin` for i.MX 8DXL B0.
6. If using OP-TEE, copy `tee.bin` to `imx-mkimage/iMX8DXL/` and copy `u-boot/spl/u-boot-spl.bin` to `imx-mkimage/iMX8DXL/`. Run `make SOC=iMX8DXL flash_spl` to generate `flash.bin`.
7. If skipping loading V2X firmware, add `V2X=NO` to make command, like `make SOC=iMX8DXL V2X=NO flash`.

The following is a matrix table for targets of i.MX 8QuadMax and i.MX 8QuadXPlus.

Table 67. Matrix table for targets of i.MX 8QuadMax, i.MX 8QuadXPlus, and i.MX 8DXL

-	OP-TEE	U-Boot	SPL	Cortex-M4
<code>flash_spl</code>	Yes	Yes	Yes	No
<code>flash</code>	No	Yes	No	No
<code>flash_linux_m4</code>	Yes	Yes	Yes	Yes
<code>flash_regression_linux_m4</code>	No	Yes	No	Yes

For i.MX 8ULP EVK, to build `imx-boot` image by using `imx-mkimage`, perform the following steps:

1. Copy `u-boot.bin` from `u-boot/u-boot.bin` and `u-boot-spl.bin` from `u-boot/spl/u-boot-spl.bin` to `imx-mkimage/iMX8ULP/`.
2. Copy `bl31.bin` from Arm Trusted firmware (`imx-atf`) to `imx-mkimage/iMX8ULP/`.
3. Copy the image of Sentinel firmware container `mx8ulpa0-ahab-container.img` to `imx-mkimage/iMX8ULP/`.
4. Copy the image of uPower firmware image `upower.bin` to `imx-mkimage/iMX8ULP/`.
5. Copy the Cortex-M33 image `m33_image.bin` to `imx-mkimage/iMX8ULP/`.
6. If using OP-TEE, copy `tee.bin` to `imx-mkimage/iMX8ULP/`. The `bl31.bin` copied in Step 2 must be built with OP-TEE SPD enabled.
7. Run `make SOC=iMX8ULP flash_singleboot_m33` to generate `flash.bin`.

**Note:** For the location where the binaries for Sentinel/SECO/uPower/M33/V2X firmwares are available to download, see the Table "BSP and multimedia standard packages" in the i.MX Linux Release Notes (IMXLXRN).

The following table list the imx-mkimage targets used on i.MX 8ULP.

Table 68. imx-mkimage targets used on i.MX 8ULP

Boot type	Cortex-A35	Cortex-M33	SW5[8:1]
Single Boot	(Default) Boot Cortex-A35 + Cortex-M33 from eMMC: make SOC=iMX8ULP flash_singleboot_m33		1000_xx00 Single Boot-eMMC
	Boot Cortex-A35 + Cortex-M33 from FlexSPI NOR: make SOC=iMX8ULP flash_singleboot_m33_flexspi		1010_xx00 Single Boot-NOR
Dual Boot	make SOC=iMX8ULP flash_dualboot	For RAM target: make SOC=iMX8ULP	1000_0010 A35-eMMC/M33-NOR
	make SOC=iMX8ULP flash_dualboot_flexspi	flash_dualboot_m33For Flash target: make SOC=iMX8ULP flash_dualboot_m33_xip	1010_0010 A35-Nor/M33-NOR
Low Power Boot	-		1000_00x1 A35-eMMC/M33-NOR
	-		1010_00x1 A35-Nor/M33-NOR

For i.MX 8M EVK, to build imx-boot image by using imx-mkimage, perform the following steps:

- Copy and rename mkimage from u-boot/tools/mkimage to imx-mkimage/iMX8M/mkimage\_uboot.
- Copy u-boot-spl.bin from u-boot/spl/u-boot-spl.bin to imx-mkimage/iMX8M/.
- Copy u-boot-nodtb.bin from u-boot/u-boot-nodtb.bin to imx-mkimage/iMX8M/.
- Copy imx8mq-evk.dtb (for i.MX 8M Quad EVK), imx8mm-evk.dtb (for i.MX 8M Mini LPDDR4 EVK), imx8mm-ddr4-evk.dtb (for i.MX 8M Mini DDR4 EVK), or imx8mp-evk.dtb (for i.MX 8M Plus LPDDR4 EVK) from u-boot/arch/arm/dts/ to imx-mkimage/iMX8M/.
- Copy bl31.bin from Arm Trusted Firmware (imx-atf) to imx-mkimage/iMX8M/.
- Copy firmware/hdmi/cadence/signed\_hdmi\_imx8m.bin from the firmware-imx package to imx-mkimage/iMX8M/.
- For i.MX 8M Quad and i.MX 8M Mini LPDDR4 EVK, copy lpddr4\_pmu\_train\_1d\_dmem.bin, lpddr4\_pmu\_train\_1d\_imem.bin, lpddr4\_pmu\_train\_2d\_dmem.bin, and lpddr4\_pmu\_train\_2d\_imem.bin from firmware/ddr/synopsys of the firmware-imx package to imx-mkimage/iMX8M/.  
For i.MX 8M Mini DDR4 EVK, copy ddr4\_imem\_1d.bin, ddr4\_dmem\_1d.bin, ddr4\_imem\_2d.bin, and ddr4\_dmem\_2d.bin from firmware/ddr/synopsys of the firmware-imx package to imx-mkimage/iMX8M/.  
For i.MX 8M Plus LPDDR4 EVK, copy lpddr4\_pmu\_train\_1d\_dmem\_201904.bin, lpddr4\_pmu\_train\_1d\_imem\_201904.bin, lpddr4\_pmu\_train\_2d\_dmem\_201904.bin, and lpddr4\_pmu\_train\_2d\_imem\_201904.bin from firmware/ddr/synopsys of the firmware-imx package to imx-mkimage/iMX8M/.
- For i.MX 8M Quad EVK, run make SOC=iMX8M flash\_evk to generate flash.bin (imx-boot image) with HDMI FW included.  
For i.MX 8M Mini LPDDR4 EVK, run make SOC=iMX8MM flash\_evk to generate flash.bin (imx-boot image).  
For i.MX 8M Mini DDR4 EVK, run make SOC=iMX8MM flash\_ddr4\_evk to generate flash.bin (imx-boot image).  
For i.MX 8M Plus LPDDR4 EVK, run make SOC=iMX8MP flash\_evk to generate flash.bin (imx-boot image).

To boot with eMMC fasboot on i.MX 8M Quad EVK and i.MX 8M Mini LPDDR4 EVK, use `flash_evk_emmc_fastboot` target.

For i.MX 93 A1 and i.MX 91P, to build `imx-boot` image by using `imx-mkimage`, perform the following steps:

1. Copy `u-boot.bin` from `u-boot/u-boot.bin` and `u-boot-spl.bin` from `uboot/ spl/u-boot-spl.bin` to `imx-mkimage/iMX93/`.
2. Copy `bl31.bin` from Arm Trusted firmware (`imx-atf`) to `imx-mkimage/iMX93/`.
3. Copy the image of Sentinel firmware container `mx93a1-ahab-container.img` to `imx-mkimage/iMX9/`.
4. If using OP-TEE, copy `tee.bin` to `imx-mkimage/iMX93/`. The `bl31.bin` copied in Step 2 must be built with OP-TEE SPD enabled.
5. Run the following command to generate `flash.bin`.

- For i.MX 93 A1:

```
make SOC=iMX9 REV=A1 flash_singleboot
```

- For i.MX 91P:

```
make SOC=iMX91 REV=A1 flash_singleboot
```

To generate boot image for FlexSPI NAND boot on i.MX 91P, run the following command:

```
make SOC=iMX91 REV=A1 flash_singleboot_spinand
```

**Note:** Two binaries are generated:

- `flash.bin` is the boot image burned into the SPI NAND.
- `flash_fw.bin` is the NAND UUU FW image used by the UUU tool.

For i.MX 95, to build `imx-boot` image by using `imx-mkimage`, perform the following steps:

1. Copy `u-boot.bin` from `u-boot/u-boot.bin` and `u-boot-spl.bin` from `uboot/spl/u-bootspl.bin` to `imx-mkimage/iMX95/`.
2. Copy `bl31.bin` from Arm Trusted firmware (`imx-atf`) to `imx-mkimage/iMX95/`.
3. Copy the image of ELE and V2X container `mx95a1-ahab-container.img` to `imx-mkimage/iMX95/`.
4. Copy the System Manager image `M33_image.bin` to `imx-mkimage/iMX95/`.
5. Copy the SDK image `M7_image.bin` to `imx-mkimage/iMX95/`.
6. Copy the OEI images `oei-m33-ddr.bin` and `oei-m33-tcm.bin` to `imx-mkimage/iMX95/`.
7. Copy the DDR PHY firmware images `lpddr5_dmem_v202306.bin` and `lpddr5_imem_v202306.bin` to `imx-mkimage/iMX95/`.
8. Select one of following commands to generate `flash.bin`:

- For all images, run:

```
make SOC=iMX95 OEI=YES flash_all
```

- For Cortex-A55 images, and without Cortex-M7, run:

```
make SOC=iMX95 OEI=YES flash_a55
```

- For Cortex-A55 images for FlexSPI NOR boot, and without Cortex-M7, run:

```
make SOC=iMX95 OEI=YES flash_a55_flexspi
```

## 4.6 Flash memory maps

This section describes the software layout in memory on memory devices used on the i.MX boards.

This information is useful for understanding subsequent sections about image downloading and how the images are placed in memory.

The `mtdparts` directive can be used in the Linux boot command to specify memory mapping. The following example briefly describes how to use memory maps. Memory is allocated in the order of how it is listed. The dash (-) indicates the the rest of the memory.

```
mtdparts=[memory type designator]:[size]([name of partition]),[size]([name of partition]),-([name of final partition])
```

#### 4.6.1 MMC/SD/SATA memory map

The MMC/SD/SATA memory scheme is different from the NAND and NOR flash, which are deployed in the BSP software. The MMC/SD/SATA must keep the first sector (512 bytes) as the Master Boot Record (MBR) to use MMC/SD as the rootfs.

Upon boot-up, the MBR is executed to look up the partition table to determine which partition to use for booting. The bootloader should be after the MBR. The kernel image and rootfs may be stored at any address after the bootloader. By default, the the U-Boot boot arguments use the first FAT partition for kernel and DTB, and the following ext3 partition for the root file system. Alternatively, users can store the kernel and the DTB in any raw memory area after the bootloader. The boot arguments must be updated to match any changed memory addresses.

The MBR can be generated through the `fdisk` command when creating partitions in MMC/SD cards on a Linux host server.

#### 4.6.2 NAND flash memory map

The NAND flash memory map is configured from the Linux kernel command line.

For example:

```
mtdparts=gpmi-nand:64m(boot),16m(kernel),16m(dtb),-(rootfs)
```

#### 4.6.3 Parallel NOR flash memory map

The default configuration contains only one parallel NOR partition. The parallel NOR device is generally 4 MB. U-Boot is loaded at the beginning of parallel NOR so that the device can boot from it. The default configuration is that on boot up, U-Boot loads the kernel, DTB, and root file system from the SD/MMC card into DDRAM. The end user can change the default settings according to their needs. More partitions can be added through the kernel command line. The memory type designator for the command below consists of the NOR address and the designator. This information can be found in the i.MX `.dtsidevice tree` file in `arch/arm/boot/dts`. The following is an example of what might be added to the Linux boot command line:

```
mtdparts=8000000.nor:1m(uboot),-(rootfs)
```

The address for parallel NOR is 0x8000000 for i.MX 6 SABRE-AI.

#### 4.6.4 SPI-NOR flash memory map

The SPI-NOR flash memory can be configured using the Linux kernel command line.

U-Boot should be loaded at the 1 KB offset of the SPI-NOR memory, so that the device can boot from it. The default configuration is that on boot up, U-Boot loads the kernel, DTB, and root file system from the SD/MMC card into DDRAM. The end user can change the default settings according to their needs. More partitions can



be added through the kernel command line. The following is an example of what might be added to the Linux boot command line:

```
mtddparts=spi32766.0:768k(uboot),8k(env),128k(dtb),-(kernel)
```

### 4.6.5 QuadSPI flash memory map

The QuadSPI flash memory can be configured using the Linux kernel command line.

U-Boot is loaded at the beginning of the QuadSPI memory so that the device can boot from it. The default configuration is that on boot up, U-Boot loads the kernel, DTB, and root file system from the SD/MMC card into DDRAM. The end user can change the default settings according to their requirements. More partitions can be added through the kernel command line. The following is an example of what might be added to the Linux boot command line:

```
mtddparts=21e4000.qspi:1m(uboot),8m(kernel),1m(dtb),-(user)
```

U-Boot has the mapping below to help in accessing the QuadSPI flash in U-Boot for non-parallel mode.

**Table 69. U-Boot mapping for QuadSPI**

Device on hardware	Device in U-Boot	Memory address in U-Boot	Remark
QuadSPI1 Port A CS0	sf probe 0:0 on i.MX 6SoloX SABRE-AI board, i.MX 7Dual SABRE-SD board, i.MX 6UltraLite EVK board, i.MX 8QuadMax MEK, i.MX 8QuadXPlus MEK, and i.MX 8DXL EVK	0x60000000 0x08000000	-
QuadSPI1 Port B CS0	sf probe 1:0 on i.MX 6 SoloX SABRE-AI board	0x68000000	-
QuadSPI2 Port A CS0	sf probe 0:0 on i.MX 6SoloX SABRE-SD board	0x70000000	-
QuadSPI2 Port B CS0	sf probe 1:0 on i.MX 6SoloX SABRE-SD board	0x78000000	-

**Table 70. U-Boot mapping for FlexSPI for i.MX 8ULP**

Device on hardware	Device in U-Boot	Memory address in U-Boot	Remark
Flexspi0 PortA CS0	sf probe 0:0	0x04000000	-
Flexspi2 PortA CS0	sf probe 2:0	0x60000000	-

## 4.7 Running Linux OS on the target

This section describes how to run a Linux image on the target using U-Boot.

These instructions assume that you have downloaded the kernel image using the instructions in [Section 4.4](#) or [Section 4.3](#). If you have not set up your Serial Terminal, see [Section 3](#).

The basic procedure for running Linux OS on an i.MX board is as follows. This document uses a specific set of environment variable names to make it easier to describe the settings. Each type of setting is described in its own section as follows.

1. Power on the board.

2. When U-Boot comes up, set the environment variables specific to your machine and configuration. Common settings are described below and settings specific to a device are described in separate sections.
3. Save the environment setup:

```
U-Boot > saveenv
```

4. Run the boot command:

```
U-Boot > run bootcmd
```

The commands `env default -f -a` and `saveenv` can be used to return to the default environment.

### Specifying the console

The console for debug and command-line control can be specified on the Linux boot command line. The i.MX 6Quad SABRE-AI board uses `ttymxc2`, so it is not same for all boards. It is usually specified as follows, but the baud rate and the port can be modified. Therefore, for NFS, it might be `ttymxc3`.

```
U-Boot > setenv consoleinfo 'console=ttymxc2,115200'
```

For the i.MX 7ULP EVK, i.MX 8QuadMax MEK boards, and i.MX 8QuadXPlus MEK board, change to "`console=ttylp0,115200`".

### Specifying displays

The display information can be specified on the Linux boot command line. It is not dependent on the source of the Linux image. If nothing is specified for the display, the settings in the device tree are used. Add `displayinfo` to the environment macro containing `bootargs`. The specific parameters can be found in the *i.MX Linux Release Notes (IMXLXRN)*. The following are some examples of these parameters.

- U-Boot > `setenv displayinfo 'video=mxcfb0:dev=hdmi,1920x1080M@60,if=RGB24'` for an HDMI display
- U-Boot > `setenv displayinfo 'video=mxcfb1:dev=ldb video=mxcfb0:dev=hdmi,1920x1080M@60,if=RGB24'` for LVDS and HDMI dual displays
- U-Boot > `setenv displayinfo 'video=mxcfb0:dev=lcd,if=RGB565'` for an LCD
- U-Boot > `setenv displayinfo 'video=mxcepdcfb:E060SCM,bpp=16 max17135:pass=2,vcom=-2030000'` for an EPDC connection
- U-Boot > `setenv displayinfo 'video=mxcfb0:mxcfb0:dev=lcd,if=RGB565 video=mxcfb1:dev=hdmi,1920x1080M@60,if=RGB24'` for LCD and HDMI dual displays

### Specifying memory addresses

The addresses in the memory where the kernel and device tree are loaded to do not change based on the device that runs Linux OS. The instructions in this chapter use the environment variables `loadaddr` and `fdt_addr` to indicate these values. The following table shows the addresses used on different i.MX boards.

Table 71. Board-specific default values

Variable	6Quad, 6 QuadPlus, and 6Dual Lite SABRE (AI and SD)	6SoloX SD	7Dual SABRE-SD	6UltraLite, 6ULL and 6ULZ EVK	7ULP EVK	8Quad Max, 8 QuadXPlus, 8DualX, and 8DXL	8ULP	8M Quad/8M Mini EVK	i.MX 93	i.MX 95	Description
<code>loadaddr</code>	0x12000000	0x80800000	0x80800000	0x80800000	0x60800000	0x80200000	0x80400000	0x40400000	0x80400000	0x90400000	Address in the memory the kernel are loaded to
<code>fdt_addr</code>	0x18000000	0x83000000	0x83000000	0x83000000	0x63000000	0x83000000	0x83000000	0x43000000	0x83000000	0x93000000	Address in the memory the device tree code are copied to

In addition, `fdtfile` is used to specify the filename of the device tree file. The commands used to set the U-Boot environment variables are as follows:

```
U-Boot > setenv loadaddr 0x80080000
U-Boot > setenv fdtaddr 0x80f00000
U-Boot > setenv fdtfile fsl-imx7ulp-evk.dtb
```

### Specifying the location of the root file system

The rootfs can be located on a device on the board or on NFS. The settings below show some options for specifying these.

- U-Boot > setenv rootfsinfo 'root=/dev/nfs ip=dhcp nfsroot=\${serverip}:  
\${nfsroot},v3,tcp'
- U-Boot > setenv rootfsinfo 'root=/dev/nfs ip=dhcp weim-nor nfsroot=\${serverip}:  
\${nfsroot},v3,tcp'
- U-Boot > setenv rootfsinfo 'ubi.mtd=4 root=ubi0:rootfs rootfstype=ubifs rootwait  
rw mtdparts=gpmi-nand:64m(boot),16m(kernel),16m(dtb),-(rootfs)'
- U-Boot > setenv rootfsinfo 'root=/dev/mmcblk0p2 rootwait rw'

### Special settings

i.MX 6Solo, and 6UltraLite can specify `uart_from_osc` on the command line to specify that the OSC clock rather than PLL3 should be used. This allows the system to enter low power mode.

```
U-Boot > setenv special 'uart_from_osc'
```

### Creating the boot command line

For clarification, this document groups the bootargs into one macro as follows:

```
U-Boot > setenv bootargsset 'setenv bootargs ${consoleinfo} ${rootfsinfo}  
${displayinfo} ${special}'
```

The executed boot command is then as follows. Arguments vary by device.

```
U-Boot > setenv bootcmd 'run bootargsset; {settings-for-device}; bootz  
${loadaddr} - ${fdt_addr}'
```

#### 4.7.1 Running the image from NAND

NAND can be found on i.MX 6 SABRE-AI boards.

Power on the board, and then enter the commands provided. The following settings may be used to boot the Linux system from NAND.

Assume that the kernel image starts from the address 0x1400000 byte (the block starting address is 0x800). The kernel image size is less than 0x400000 byte. The rootfs is located in `/dev/mtd2`.

```
U-Boot > setenv bootcmd 'run bootargsset; nand read ${loadaddr} 0x1000000  
0x800000; nand read ${fdt_addr} 0x2000000 0x100000; bootz ${loadaddr} -  
${fdt_addr}'
```

### 4.7.2 Running Linux OS from Parallel NOR

Parallel NOR is available on i.MX 6 SABRE-AI boards. The following procedure can be used to boot the system from Parallel NOR.

1. Assume that the kernel image starts at address 0xc0000 bytes.
2. At the U-Boot prompt, set up these variables:

```
U-Boot > setenv bootcmd 'run bootargsset; cp.b 0x80c0000 ${loadaddr}
0x800000;cp.b 0x80a0000 ${fdt_addr} 0x20000;bootz ${loadaddr} - ${fdt_addr}
'
```

### 4.7.3 Running the Linux OS image from QuadSPI

QuadSPI is available on i.MX 6SoloX SABRE-SD boards, i.MX 7Dual SABRE-SD boards, i.MX 6UltraLite EVK boards, i.MX 6ULL EVK boards, and i.MX 8QuadMax MEK, and i.MX 8QuadXPlus MEK. The following procedure may be used to boot the Linux system from QuadSPI NOR.

1. Assume that the kernel image starts from the address 0xA00000 byte and the DTB file starts from address 0x800000.
2. At the U-Boot prompt, set the following environment variables:

```
U-Boot > setenv bootcmd 'run bootargsset; sf probe; sf read ${loadaddr}
0xA00000 0x2000; sf read ${fdt_addr} 0x800000 0x800; bootz ${loadaddr} -
${fdt_addr} '
```

### 4.7.4 Running the Arm Cortex-M4/7/33 image

On the i.MX 6SoloX boards, there are two ways to boot Arm Cortex-M4 images in U-Boot:

- Arm Cortex-M4 processor Normal Up (supported on i.MX 6SoloX SABRE-AI and SABRE-SD boards). Performed by running the U-Boot command. Requires:
  1. U-Boot normal SD image if Arm Cortex-A9 processor boots from the SD card. U-Boot normal QSPI image if Arm Cortex-A9 processor boots from the QSPI NOR flash.
  2. Kernel DTB: `imx6sx-sdb-m4.dtb` for i.MX 6SoloX SABRE-SD board. `imx6sx-sabreauto-m4.dtb` for i.MX 6SoloX SABRE-AI board.
  3. Have the Arm Cortex-M4 image burned. (NOR flash of QuadSPI2 PortB CS0 for i.MX 6SoloX SABRE-SD board. NOR flash of QuadSPI1 PortB CS0 for i.MX 6SoloX SABRE-AI board.)
- Arm Cortex-M4 processor Fast Up (only supported on i.MX 6SoloX SABRE-SD boards). Initiated by U-Boot at a very early boot phase to meet the requirement of Arm Cortex-M4 processor booting in 50 ms. No U-Boot command is involved. Requires:
  1. U-Boot Arm Cortex-M4 fast up image and Arm Cortex-A9 processor must boot from the QSPI2 NOR flash.
  2. Kernel DTB: `imx6sx-sdb-m4.dtb`.
  3. Have the Arm Cortex-M4 image burned (NOR flash of QuadSPI2 PortB CS0).

To facilitate the Arm Cortex-M4 processor Normal Up, a script has been added to the default U-Boot. The following steps may help users who need to run the Cortex-M4 processor Normal Up script.

1. Power on the board.
2. On the i.MX 6SoloX SABRE-SD board, assumed that the Arm Cortex-M4 image is at address 0x78000000 (NOR flash of QuadSPI2 PortB CS0). On the i.MX 6SoloX SABRE-AI board, assumed that the Arm Cortex-M4 image is at address 0x68000000 (NOR flash of QuadSPI1 PortB CS0).

At the U-Boot prompt:

```
U-Boot > run m4boot
```

Or users can perform the commands without depending on the script:

```
U-Boot > sf probe 1:0
```

For the i.MX 6SoloX SABRE-SD board:

```
U-Boot > bootaux 0x78000000
```

For the i.MX 6SoloX SABRE-AI board:

```
U-Boot > bootaux 0x68000000
```

**Note:**

For how to add the MCC demo to the kernel and limit RAM available to kernel to use it, see Chapter 53 "i.MX 6 SoloX MultiCore Communication (MCC)" of the i.MX Linux Reference Manual (IMXLXRM).

As well as supporting running the Arm Cortex-M4 image from QuadSPI, the default i.MX 7Dual SABRE-SD board supports loading the Arm Cortex-M4 image from the SD card and running it on OCRAM.

Prepare the Arm Cortex-M4 image to the FAT partition of the SD card. Name the file to `m4_qspi.bin` when using `m4boot` script.

After the board is powered on, the following information is displayed at the U-Boot prompt:

```
U-Boot > run m4boot
```

Or perform the commands without depending on the script:

```
u-boot=> fatload mmc 0:0 ${loadaddr} m4_qspi.bin
u-boot=> cp.b ${loadaddr} 0x7e0000 ${filesize}
u-boot=> bootaux 0x7e0000
```

**Note:**

If your image has no resource table, such as NXP `hello_world.bin`, clear the resource table area. Otherwise, Linux OS may shows the garbage value.

- For i.MX 8M Mini/Nano/Quad LPDDR4 EVK: run `#mw 0xb80ff000 0 4` to clear the garbage resource table area.
- For i.MX 8M Plus LPDDR4 EVK: run `#mw 0x550ff000 0 4` to clear the garbage resource table area.

On the i.MX 8M boards, perform the commands to boot the Arm Cortex-M Core core:

```
u-boot=> fatload mmc 1:1 ${loadaddr} m4.bin
u-boot=> cp.b ${loadaddr} 0x7e0000 ${filesize}
u-boot=> run prepare_mcore
u-boot=> bootaux 0x7e0000
```

There are two methods to start the remote core: U-Boot `bootaux` and Linux `remoteproc`.

Whether to use `bootaux` or `remoteproc` to start the remote core, use `remoteproc` to stop or start the Cortex-M core for debug purposes only. It is not recommended to stop the Cortex-M core from Linux OS in a production system.

If you choose to use `remoteproc` to start the remote core directly, execute `run prepare_mcore` in U-Boot before starting the Linux OS.

On the i.MX 8QuadMax and i.MX 8QuadXPlus boards, there are two ways to boot the Arm Cortex-M4 cores:

- **Booting from ROM**

Users need to use `imx-mkimage` to pack the Arm Cortex-M4 images into `imx-boot` image. It is necessary to specify the core ID and its TCML address in the build command. The following is an example:

```
flash_linux_m4: $(MKIMG) mx8qmb0-ahab-container.img scfw_tcm.bin u-boot-spl.bin
m4_image.bin m4_1_image.bin u-boot-atf-container.img
./$(MKIMG) -soc QM -rev B0 -dcd skip -append mx8qmb0-ahab-container.img -c -
flags 0x00200000 -scfw scfw_tcm.bin -ap u-boot-spl.bin a53 0x00100000 -p3 -m4
m4_image.bin 0 0x34FE0000 -p4 -m4 m4_1_image.bin 1 0x38FE0000 -out flash.bin
cp flash.bin boot-spl-container.img
@flashbin_size=`wc -c flash.bin | awk '{print $$1}'`; \
pad_cnt=$((flashbin_size + 0x400 - 1) / 0x400); \
echo "append u-boot-atf-container.img at $$pad_cnt KB"; \
dd if=u-boot-atf-container.img of=flash.bin bs=1K seek=$
$pad_cnt;
```

**Note:**

When booting with the packed Cortex-M4 image (`flash_linux_m4`), use kernel DTB with `RPMSG` enabled, like `fsl-imx8qm-mek-rpmsg.dtb` for i.MX 8QuadMax MEK or `fsl-imx8qxp-mek-rpmsg.dtb` for i.MX 8QuadXPlus MEK.

- **Booting from U-Boot (not support multiple partitions enabled)**

U-Boot supports loading the Arm Cortex-M4 image from the FAT partitions of the SD card with default name `m4_0.bin` and `m4_1.bin`. After the board is booted into the U-Boot console, use the following command to boot Arm Cortex-M4 core 0:

```
U-Boot > run m4boot_0
Or the command to boot M4 core 1:
U-Boot > run m4boot_1
Or perform the commands for core 0 without depending on the script:
U-Boot > fatload mmc 1:1 0x80280000 m4_0.bin
U-Boot > dcache flush; bootaux 0x80280000 0
```

On the i.MX 93 11x11 EVK, use `bootaux`:

```
=> fatload mmc 1:1 ${loadaddr} imx93-11x11-
evk_m33_TCM_rpmsg_lite_str_echo_rtos.bin
15948 bytes read in 4 ms (3.8 MiB/s)
=> cp.b ${loadaddr} 0x201e0000 ${filesize}
=> bootaux 0x1ffe0000 0
## Starting auxiliary core stack = 0x20020000, pc = 0x0FFE05D5...
```

Pass `clk_ignore_unused` in `bootargs` when using `bootaux` to kick Arm Cortex-M33. This would increase overall consumption.

For i.MX 93, users can directly start/stop Cortex-M33 using `remoteproc` as follows:

```
[ 138.693391] remoteproc remoteproc0: stopped remote processor imx-rproc
root@imx93evk:~# echo ~/imx93_m33_TCM_rpmsg_lite_str_echo_rtos_imxcm33.elf > /
sys/devices/platform/imx93-cm33/remoteproc/remoteproc0/firmware
root@imx93evk:~# echo start > /sys/devices/platform/imx93-cm33/remoteproc/
remoteproc0/state
[ 162.361023] remoteproc remoteproc0: powering up imx-rproc
[ 162.368617] remoteproc remoteproc0: Booting fw image
imx93_m33_TCM_rpmsg_lite_str_echo_rtos_imxcm33.elf, size 175644
```

```
[ 162.916805] remoteproc0#vdev0buffer: assigned reserved memory node
vdevbuffer@a4020000
[ 162.926429] virtio_rpmsg_bus virtio0: rpmsg host is online
[ 162.935336] remoteproc0#vdev0buffer: registered virtio0 (type 7)
[ 162.941986] remoteproc0#vdev1buffer: assigned reserved memory node
vdevbuffer@a4020000
[ 162.951071] virtio_rpmsg_bus virtio1: rpmsg host is online
[ 162.956649] virtio_rpmsg_bus virtio1: creating channel rpmsg-virtual-tty-
channel addr 0x1e
[ 162.962559] remoteproc0#vdev1buffer: registered virtio1 (type 7)
[ 162.971179] remoteproc remoteproc0: remote processor imx-rproc is now up
root@imx93evk:~#
root@imx93evk:~# echo stop > /sys/devices/platform/imx93-cm33/remoteproc/
remoteproc0/state
[ 172.114287] remoteproc remoteproc0: stopped remote processor imx-rproc
```

**4.7.5 Linux OS login**

The default login user name for the i.MX Linux OS is `root` with no password.

**4.7.6 Running Linux OS from MMC/SD**

This scenario assumes that the board is configured to boot U-Boot, that the Linux kernel image is named `zImage` and is stored on the SD card in an MS-DOS FAT partition, and one or more device tree files are also stored in this partition. The `rootfs` is also stored on the SD/MMC card in another partition.

When U-Boot boots up, it detects the slot where it is booting from and automatically sets `mmcdev` and `mmcroot` to use the `rootfs` on that SD card. In this scenario, the same SD card can be used to boot from any SD card slot on an i.MX 6/7 board, without changing any U-Boot settings. From the U-Boot command line, type `boot` to run Linux OS.

The following instructions can be used if the default settings are not desired.

Set `mmc autodetect` to "no" to turn off the automatic setting of the SD card slot in `mmcdev` and `mmcroot`. The U-Boot `mmcdev` is based on the soldered SD/MMC connections, so it varies depending on the board. The U-Boot `mmc dev 0` is the lowest numbered SD slot present, 1 is the next, and so on. The Linux kernel, though, indexes all the uSDHC controllers whether they are present or not. The following table shows this mapping.

**Table 72. Linux uSDHC relationships**

uSDHC	mmcroot
uSDHC 1	mmcblk0*
uSDHC 2	mmcblk1*
uSDHC 3	mmcblk2*
uSDHC 4	mmcblk3*

In the default configuration of the SD card and the example here, U-Boot is at the 1024 byte offset, 32 KB offset for the i.MX 8QuadXPlus B0 and i.MX 8QuadMax B0, or 33 KB offset for the i.MX 8QuadXPlus A0, i.MX 8QuadMax A0, i.MX 8M EVK boards before the first partition, partition 1 is the partition with the Linux kernel and device trees, and partition 2 is the `rootfs`.

**Setting up the environment variables**

For convenience, this document uses a standard set of variables to describe the information in the Linux command line. The values used here may be different for different machines or configurations. By default, U-Boot supports setting `mmcdev` and `mmcroot` automatically based on the uSDHC slot that we boot from.

This assumes zImage, the device tree file (DTB), and the rootfs are on the same SD/MMC card. To set these environment variables manually, set `mmc autodetect` to `no` to disable the feature.

The following is one way to set up the items needed to boot Linux OS.

```
U-Boot > setenv mmcpart 1
U-Boot > setenv loadfdt 'fatload mmc ${mmcdev}:${mmcpart} ${fdt_addr}
  ${fdtfile}'
U-Boot > setenv loadkernel 'fatload mmc ${mmcdev}:${mmcpart} ${loadaddr} zImage'
U-Boot > setenv bootcmd 'mmc dev ${mmcdev}; run loadkernel; run mmcargs; run
  loadfdt; bootz ${loadaddr} - ${fdt_addr};'
```

The descriptions of the variables used above are as follows:

- `mmcpart` - This is the partition on the MMC/SD card containing the kernel image.
- `mmcroot` - The location of the root file system on the MMC SD card along with directives for the boot command for the rootfs.

**Note:** The U-Boot environment on the pre-built SD card does not match this. It is more complex so that it can automatically deal with more variations. The example above is designed to be easier to understand and use manually.

### Reading the kernel image from eMMC

eMMC has user area, boot partition 1, and boot partition 2. To switch between the eMMC partitions, the user needs to use the command `mmc dev [dev id] [partition id]`. For example,

```
mmc dev 2 0 ---> user area
mmc dev 2 1 ---> boot partition 1
mmc dev 2 2 ---> boot partition 2
```

### 4.7.7 Running the Linux image from NFS

To boot from Network File System (NFS), set the following environment variables at the U-Boot prompt:

```
U-Boot > setenv serverip <your server IP>
U-Boot > setenv image <your kernel zImage name on the TFTP server>
U-Boot > setenv fdtfile <your dtb image name on the TFTP server>
U-Boot > setenv rootfsinfo 'setenv bootargs ${bootargs} root=/dev/nfs ip=dhcp \
  nfsroot=${serverip}:/data/rootfs_home/rootfs_mx6,v3,tcp'
U-Boot > setenv bootcmd_net 'run rootfsinfo; dhcp ${image}; dhcp ${fdt_addr} \
  ${fdtfile}; booti ${loadaddr} - ${fdt_addr}'
U-Boot > setenv bootcmd 'run bootcmd_net'
```

**Note:** If the MAC address has not been burned into the fuses, set the MAC address to use the network in U-Boot.

```
# eth0:
setenv ethaddr xx:xx:xx:xx:xx:xx
# eth1:
setenv eth1addr xx:xx:xx:xx:xx:xx
```

## 4.8 Arm SystemReady-IR



### 4.8.1 Arm SystemReady-IR ACS compliance test

To run the SystemReady-IR ACS on the i.MX 8M Mini EVK board, refer to the Arm SystemReady-IR ACS from: <https://github.com/ARM-software/arm-systemready>

1. Clone the ACS Git.
2. Flash the pre-build release image or image built from source code on to the U-Disk, SD, or eMMC. If the target storage is also boot storage, flash the boot image (`flash.bin`) thereafter the ACS image. For example, on the U-Disk:

```
sudo dd if=ir_acs_live_image.img of=/dev/sde bs=64M;sync
```

3. Boot the board. The ACS test will automatically run up.
4. There will be manual step for the power-off test from ACS. Just re-power on the board when run into that test case.  
The test result will be stored on the storage.
5. Use the SCT\_Parser to analyze the ACS result. The SCT\_Parser can be obtained from: [https://github.com/vstehle/SCT\\_Parser](https://github.com/vstehle/SCT_Parser)
6. Copy the `acs_results\sct_results\Overall\Summary.ekl` file from the RESULT partition in U-disk to the SCT\_Parser folder. Run `python3 parser.py --config EBBR.yaml Summary.ekl EBBR.seq` to get the final report.

### 4.8.2 Capsule update

Use the following command to do the capsule update:

- For SD:

```
U-Boot > env set dfu_alt_info "mmc 1=1 raw 0x42 0x2000"
```

- For eMMC:

```
U-Boot > env set dfu_alt_info "mmc 2=1 raw 0x42 0x2000 mmcpart 1"
U-Boot > efidebug boot add 0 Boot0000 mmc 1:1 capsule1.bin;efidebug boot next 0
U-Boot > setenv serverip 10.192.242.218;dhcp $loadaddr capsule1.bin;fatwrite
mmc 1:1 ${loadaddr} /EFI/UpdateCapsule/capsule1.bin 0x${filesize}
U-Boot > setenv -e -nv -bs -rt -v OsIndications =0x04
U-Boot > efidebug capsule disk-update
reset
```

Do not interrupt U-Boot. Let the board run into grub. Before grub runs, it should update the bootloader automatically and remove `capsule1.bin`. And reboot the board again. The board will boot up with the updated U-Boot.

### 4.8.3 Linux distro installation

Fedora34:

1. Download the Fedora IoT 34 version.
2. Burned into the SD card.
3. Boot from eMMC.
4. Install distro from the SD card to eMMC.

OpenSUSE:

1. Download the OpenSUSE Tumbleweed version.
2. Burn ISO into the USB disk.
3. Boot from eMMC.

4. Install from ISO to eMMC.

## 5 Enabling Solo Emulation

Solo emulation can be enabled on the i.MX 6DualLite SABRE-SD and i.MX 6DualLite SABRE-AI boards. This is achieved by using a specific U-Boot configuration in the bootloader build process.

When this Solo emulation is enabled on the i.MX 6DualLite SABRE platforms, the capabilities of the i.MX 6DualLite change to the following:

- For solo emulation, use 6DualLite DTB and add `maxcpus=1` to `bootcmd` of U-Boot.
- 32-bit data bus on DDR RAM.
- 1 GB of RAM for i.MX 6DualLite SABRE-AI.
- 512 MB of RAM for i.MX 6DualLite SABRE-SD.

To build U-Boot for an i.MX 6Solo on an i.MX 6DualLite SABRE-SD card, use the following command:

```
MACHINE=imx6solosabresd bitbake u-boot-imx
```

To build U-Boot for an i.MX 6Solo on an i.MX 6DualLite SABRE-AI card, use the following command:

```
MACHINE=imx6solosabreauto bitbake u-boot-imx
```

## 6 Power Management

The i.MX power management uses the standard Linux interface. Check the standard Linux power documentation for information on the standard commands. The *i.MX Linux Reference Manual* (IMXLXRM) contains information on the power modes that are available and other i.MX-specific information in the power management section.

There are three main power management techniques on i.MX boards: suspend and resume commands, CPU frequency scaling, and bus frequency scaling. They are described in the following sections.

### 6.1 Suspend and resume

The power state can be changed by setting the standard Linux state, `/sys/power/state`. The command used to set the power state into suspend mode, available from the command line, is `echo mem > /sys/power/state`. The value `mem` can be replaced by any of the valid power states, as described by the *i.MX Linux Reference Manual* (IMXLXRM).

Use one of the following methods to wake up the system from suspend mode.

- The debug UART can be set as a wake-up source with:

```
echo enabled > /sys/class/tty/ttymx0/power/wakeup
```

**Note:**

*It is `ttylp0` for i.MX 8QuadXPlus and i.MX 8QuadMax, and `ttylp0` for i.MX 8DXL.*

*To identify the current debug UART and configure it as a wake-up source:*

```
echo enabled > /sys/class/tty/$(tty | cut -d '/' -f 3)/power/wakeup
```

- RTC can be used to enter and exit from suspend mode by using the command:

```
/unit_test/SRTC/rtcwakeup.out -d rtc0 -m mem -s 10
```

This command indicates to sleep for 10 secs. This command automatically sets the power state to `mem` mode.

## 6.2 CPU frequency scaling

Scaling governors are used in the Linux kernel to set the CPU frequency. CPU frequencies can be scaled automatically depending on the system load either in response to ACPI events or manually by userspace programs. For more information about governors, read `governors.txt` from [www.kernel.org/doc/Documentation/cpu-freq/governors.txt](http://www.kernel.org/doc/Documentation/cpu-freq/governors.txt).

The following are some of the more frequently used commands:

These commands return information about the system and the current settings.

- The kernel is pre-configured to support only certain frequencies. The list of frequencies currently supported can be obtained from:

```
cat /sys/devices/system/cpu/cpu0/cpufreq/scaling_available_frequencies
```

- To get the available scaling governors:

```
cat /sys/devices/system/cpu/*/cpufreq/scaling_available_governors
```

- To check the current CPU frequency:

```
cat /sys/devices/system/cpu/*/cpufreq/cpuinfo_cur_freq
```

The frequency is displayed depending on the governor set.

- To check the maximum frequency:

```
cat /sys/devices/system/cpu/*/cpufreq/cpuinfo_max_freq
```

- To check the minimum frequency:

```
cat /sys/devices/system/cpu/*/cpufreq/cpuinfo_min_freq
```

These commands set a constant CPU frequency:

- Use the maximum frequency:

```
echo performance > /sys/devices/system/cpu/cpu0/cpufreq/scaling_governor
```

- Use the current frequency to be the constant frequency:

```
echo userspace > /sys/devices/system/cpu/cpu0/cpufreq/scaling_governor
```

- The following two commands set the scaling governor to a specified frequency, if that frequency is supported. If the frequency is not supported, the closest supported frequency is used:

```
echo userspace > /sys/devices/system/cpu/cpu0/cpufreq/scaling_governor
echo <frequency> > /sys/devices/system/cpu/cpu0/cpufreq/scaling_setspeed
```

## 6.3 Bus frequency scaling

This release does not support the bus frequency scaling feature on i.MX 7ULP EVK.

This release does not support the bus frequency scaling feature on i.MX 8QuadXPlus and i.MX 8QuadMax.

The system automatically adjusts the bus frequency (DDR, AHB, etc.) for optimal performance based on the devices that are active.

The bus frequency driver is enabled by default. The following DDR frequencies are supported:

- Normal DDR frequency – Default frequency in U-Boot
- Audio DDR frequency – 50 MHz on i.MX 6Quad, i.MX 6DualLite, and i.MX 6SoloX, and 100 MHz on i.MX 7Dual.

- Low power idle DDR frequency – 24 MHz

On the i.MX 8M board:

- For LPDDR4, the Audio DDR frequency is 25 MHz, the low power idle DDR frequency is 25 MHz.
- For DDR4, the audio DDR frequency is 166 MHz, the low power idle DDR frequency is 166 MHz.

To enter a low power idle DDR frequency, ensure that all devices that require high DDR frequency are disabled. Most drivers do active clock management, but certain commands can be used to avoid waiting for timeouts to occur:

```
echo 1 > /sys/class/graphics/fb0/blank -> to blank the display (may need to blank fb1, fb2, and so on, if more than one display is active).
```

```
ifconfig eth0 down -> disables the Ethernet module. On i.MX 6SoloX, i.MX 7Dual, i.MX 6UltraLite, and i.MX 6UltraLiteLite should also disable Ethernet 1 (eth1).
```

i.MX 8M Plus needs some additional steps to enable USB runtime PM:

```
echo auto > /sys/bus/platform/devices/32f10100.usb/38100000.dwc3/power/control
echo auto > /sys/bus/platform/devices/32f10108.usb/38200000.dwc3/power/control
echo auto > /sys/bus/platform/devices/32f10108.usb/38200000.dwc3/xhci-hcd.1.auto/power/control
```

Execute the following command for i.MX 8ULP to enable system level voltage and frequency scaling:

```
ifconfig eth0 down
systemctl stop weston
echo 1 > /sys/devices/platform/imx8ulp-lpm/enable
```

On most systems, the chip enters low power IDLE mode after the above two commands are executed.

To manipulate bus frequency, use the following commands to achieve the results desired:

```
cat /sys/bus/platform/drivers/imx_busfreq/soc\:busfreq/enable -> displays the status of bus frequency.
```

```
echo 0 > /sys/bus/platform/drivers/imx_busfreq/soc\:busfreq/enable -> disables bus frequency.
```

```
echo 1 > /sys/bus/platform/drivers/imx_busfreq/soc\:busfreq/enable -> enables bus frequency.
```

The *i.MX Linux Reference Manual* (IMXLXRM) has more information on the bus frequency in the chapter about DVFS.

## 7 Multimedia

i.MX provides audio optimized software codecs, parsers, hardware acceleration units, and associated plugins. The i.MX provides GStreamer plugins to access the i.MX multimedia libraries and hardware acceleration units. This chapter provides various multimedia use cases with GStreamer command line examples.

### 7.1 i.MX multimedia packages

Due to license limitations, i.MX multimedia packages can be found in two locations:

- Standard packages: provided on the NXP mirror.
- Limited access packages: provided on [nxp.com](https://www.nxp.com) with controlled access.

For details, see the *i.MX Release Notes* (IMXLXRN).

## 7.2 Building limited access packages

Place the limited access package in the `downloads` directory and read the `readme` file in each package.

For example, README-microsoft in the package `imxcodec-microsoft-$version.tar.gz`.

## 7.3 Multimedia use cases

GStreamer is the default multimedia framework on Linux OS. The following sections provide examples of GStreamer commands to perform the specific functions indicated. The following table shows how this document refers to common functions and what the actual command is.

**Table 73. Command mapping**

Variable	\$GSTL	\$PLAYBIN	\$GPLAY	\$GSTINSPECT
GStreamer 1.x	gst-launch-1.0	playbin or playbin3	gplay-1.0	gst-inspect-1.0

One option is to set these as environment variables as shown in the following examples. Use the full path to the command on your system.

```
export GSTL=gst-launch-1.0
export PLAYBIN=playbin or export PLAYBIN=playbin3
export GPLAY=gplay-1.0
export GSTINSPECT=gst-inspect-1.0
```

In this document, variables are often used to describe the command parameters that have multiple options. These variables are of the format `$description` where the type of values that can be used are described. The possible options can be found in the Section about Multimedia in the *i.MX Linux Release Notes* (IMXLXRN) for i.MX-specific options, or at ["gstreamer.freedesktop.org/](http://gstreamer.freedesktop.org/) for the community options.

The GStreamer command line pipes the input through various plugins. Each plugin section of the command line is marked by an exclamation mark (!). Each plugin can have arguments of its own that appear on the command line after the plugin name and before the next exclamation mark (!). Use `$GSTINSPECT $plugin` to get information on a plugin and what arguments it can use.

Square brackets ([ ]) indicate optional parts of the command line.

### 7.3.1 Playback use cases

Playback use cases include the following:

- Audio-only playback
- Video-only playback
- Audio/Video file playback
- Multichannel audio playback
- Other methods for playback
- Video playback to multiple displays

#### 7.3.1.1 Audio-only playback

An audio-only playback command uses this format:

```
$GSTL filesrc location=$clip_name [typefind=true] ! [id3parse] ! queue !
$audio_parser_plugins
```

```
! $audio_decoder_plugin ! $audio_sink_plugin
```

If the file to be played contains an ID3 header, use the ID3 parser. If the file does not have an ID3 header, this has no effect.

This example plays an MP3 file in the audio jack output.

```
$GSTL filesrc location=test.mp3 ! id3demux ! queue ! mpegaudioparse ! beepdec !
pulsesink
```

### 7.3.1.2 Video-only playback

```
$GSTL filesrc location=test.video typefind=true ! $capsfilter !
$demuxer_plugin ! queue max-size-time=0 ! $video_decoder_plugin !
$video_sink_plugin
```

This is an example of an MP4 container with H.264 encoding format video file playback:

```
$GSTL filesrc location=test.mp4 typefind=true ! video/quicktime ! aiurdemux !
queue max-size-time=0 ! v4l2h264dec ! autovideosink
```

This is an example of VPU downscaling from 1920x1080 to 720x480 on i.MX 95:

```
$GSTL filesrc location=1080p.mp4 ! video/quicktime ! aiurdemux ! h264parse !
v4l2h264dec ! "video/x-raw,width=720,height=480" ! autovideosink
```

### 7.3.1.3 Audio/Video file playback

This is an example of a command to play a video file with audio:

```
$GSTL filesrc location=test_file typefind=true ! $capsfilter
! $demuxer_plugin name=demux demux.
! queue max-size-buffers=0 max-size-time=0 ! $video_decoder_plugin
! $video_sink_plugin demux.
! queue max-size-buffers=0 max-size-time=0 ! $audio_decoder_plugin
! $audio_sink_plugin
```

This is an example of an AVI file:

```
$GSTL filesrc location=test.avi typefind=true ! video/x-msvideo
! aiurdemux name=demux demux.
! queue max-size-buffers=0 max-size-time=0 ! $video_decoder_plugin
! autovideosink demux.
! queue max-size-buffers=0 max-size-time=0 ! beepdec
! alsasink
```

For the platforms without VPU hardware, `$video_decoder_plugin` could be a software decoder plugin like `avdec_h264`.

### 7.3.1.4 Multichannel audio playback

For the multichannel audio playback settings to be used when PipeWire is enabled, see [Section 7.4](#).

### 7.3.1.5 Other methods for playback

Use the `$PLAYBIN` plugin or the i.MX `$GPLAY` command line player for media file playback.

```
$GSTL $PLAYBIN uri=file:///mnt/sdcard/test.avi
$GPLAY /mnt/sdcard/test.avi
```

Supports the PCM, AC3, and DDP format audio pass-through function by the S/PDIF interface.

```
$GPLAY /mnt/sdcard/test.wav --audio-sink="alsasink
device=iec958:CARD=imxaudioxcvr,AES3=0x01 pass-through=true"
```

### 7.3.1.6 Video playback to multiple displays

Video playback to multiple displays can be supported by a video sink plugin. The video sink for multidisplay mode does not work on i.MX 8 family SoCs.

This use case requires that the system boots in multiple-display mode (dual/triple/four, the number of displays supported is determined by the SOC and the BSP). For how to configure the system to boot in this mode, see the *i.MX Porting Guide* (IMXBSPPG).

#### 7.3.1.6.1 Playing different videos on different displays

The command line to play two videos on different displays might look like this:

```
$GSTL $PLAYBIN uri=file:///file1 $PLAYBIN uri=file:///file2 video-
sink="overlaysink
display-master=false display-slave=true"
```

#### 7.3.1.6.2 Routing the same video to different displays

A video can be displayed on multiple displays with a command as follows:

```
$GSTL $PLAYBIN uri=file:///filename video-sink="overlaysink display-slave=true"
```

#### 7.3.1.6.3 Multiple videos overlay

The `overlaysink` plugin provides support for compositing multiple videos together and rendering them to the same display. The result might look like the following image.

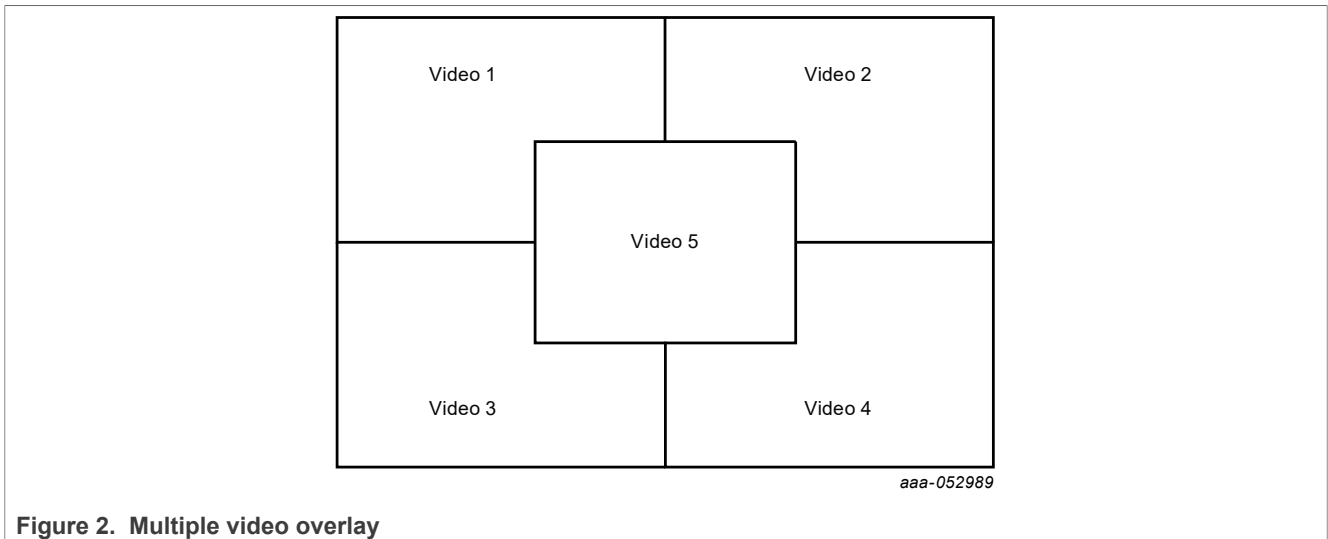

**Figure 2. Multiple video overlay**

```
gst-launch-1.0 playbin uri=file://$FILE1
  video-sink="overlaysink overlay-width=512 overlay-height=384"
  playbin uri=file://$FILE2 flags=0x41
  video-sink="overlaysink overlay-left=512 overlay-width=512 overlay-
height=384"
  playbin uri=file://$FILE3 flags=0x41
  video-sink="overlaysink overlay-top=384 overlay-width=512 overlay-
height=384"
  playbin uri=file://$FILE4 flags=0x41
  video-sink="overlaysink overlay-left=512 overlay-top=384 overlay-width=512
overlay-height=384"
  playbin uri=file://$FILE5 flags=0x41
  video-sink="overlaysink overlay-left=352 overlay-top=264 overlay-width=320
overlay-height=240 zorder=1"
```

### 7.3.2 Audio encoding

Here are some examples for MP3 encoding.

```
$GSTL filesrc location=test.wav ! wavparse ! lamemp3enc
! filesink location=output.mp3
```

### 7.3.3 Video encoding

The following commands provide some suggestions on how to use the plugins accelerated by VPU hardware to encode some media files (though they only work on a SoC with a VPU).

VPU video encoding only works on SoC with VPU encoder support.

For i.MX 6, use the following command:

```
$GSTL filesrc location=test.yuv
! videoparse format=2 width=$WIDTH height=$HEIGHT framerate=30/1
! vpuenc_xxx ! $MUXER ! filesink location=$output
```



For i.MX 8M Mini/8M Plus and i.MX 95, use the following command:

```
$GSTL filesrc location=test.yuv
! rawvideoparse format=2 width=$WIDTH height=$HEIGHT framerate=30/1
colorimetry=bt709
! v4l2xxxenc ! $MUXER ! filesink location=$output
```

- The target encoder codec type can be:
  - MPEG4, H.263, H.264, and MJPEG for i.MX 6
  - H.264, VP8 for i.MX 8M Mini
  - H.264, HEVC for i.MX 8M Plus and i.MX 95
- The vpuenc\_xxx can be:
  - vpuenc\_mpeg4, vpuenc\_h263, vpuenc\_h264, and vpuenc\_jpeg for i.MX 6
- The v4l2xxxenc can be:
  - v4l2h264enc and v4l2vp8enc for i.MX 8M Mini
  - v4l2h264enc and v4l2h265enc for i.MX 8M Plus and i.MX 95
- VPU encoder is v4l2h264enc on i.MX 8QuadMax and 8QuadXPlus.
- The \$MUXER can be set to qtmux, matroskamux, mp4mux, avimux, or flvmux.
- Different muxers support different encoded codec types. Use \$GSTINSPECT and \$MUXER to see the capabilities of the muxer to be used.

The following table lists the encoding bitrate modes for i.MX 8M Mini/8M Plus.

Table 74. Encoding bitrate modes

V4L2_CID_MPEG_VIDEO_FRAME_RC_ENABLE	Video bitrate mode	Encoded file
1	V4L2_MPEG_VIDEO_BITRATE_MODE_CBR	Bitrate takes effect limited by MIN_QP and MAX_QP. V4L2_CID_MPEG_VIDEO_BITRATE V4L2_CID_MPEG_VIDEO_H264_MIN_QP V4L2_CID_MPEG_VIDEO_H264_MAX_QP
1	V4L2_MPEG_VIDEO_BITRATE_MODE_VBR	Same as the above case but with bigger bitrate variance.
0	V4L2_MPEG_VIDEO_BITRATE_MODE_CBR/ V4L2_MPEG_VIDEO_BITRATE_MODE_VBR	Qp takes effect. V4L2_CID_MPEG_VIDEO_H264_I_FRAME_QP V4L2_CID_MPEG_VIDEO_H264_P_FRAME_QP V4L2_CID_MPEG_VIDEO_H264_B_FRAME_QP

Use extra-controls property after v4l2xxxenc to specify the value for different codec controls. v4l2-ctl --device device\_path --list-ctrls shows all video device's controls and their values.

For example:

```
gst-launch-1.0 filesrc location=test.yuv ! rawvideoparse format=2
width=$WIDTH height=$HEIGHT colorimetry=bt709 ! v4l2h264enc extra-
controls="encode,frame_level_rate_control_enable=1,h264_mb_level_rate_control=1,video_bit
filesink location=output.h264
```

### 7.3.4 Transcoding

Transcoding is converting a file from one video encoding to another.

VPU video encoding only works on SoC with VPU encoder support.

For i.MX 6 family with VPU, use the following command:

```
$GSTL filesrc location=$filename typefind=true ! $capsfilter ! aiurdemux
! vpudec ! imxvideoconvert_ipu ! $CAPS1 ! vpuenc_xxx ! matroskamux ! filesink
location=720p.mkv
```

capsfilter is the container's mime type. CAPS1 is the target video resolution, and the vpuenc\_xxx can be vpuenc\_mpeg4, vpuenc\_h263, vpuenc\_h264, and vpuenc\_jpeg.

For example:

```
gst-launch-1.0 filesrc location=$FILE.mp4 typefind=true ! video/quicktime !
aiurdemux !
vpudec ! imxvideoconvert_ipu ! video/x-raw,format=Nv12,width=1280,height=720 !
vpuenc_h264 ! [h264parse] ! matroskamux ! filesink location=$FILE.mkv
```

For i.MX 8QuadMax/8QuadXPlus, use the following command:

```
gst-launch-1.0 filesrc location=$FILE.mp4 typefind=true ! video/quicktime !
aiurdemux ! v4l2h264dec ! queue ! imxvideoconvert_g2d ! queue ! videoconvert !
queue ! v4l2h264enc ! [h264parse] ! matroskamux ! filesink location=$FILE.mkv
```

For i.MX 8M Mini/8M Plus and i.MX 95, use the following command:

```
gst-launch-1.0 filesrc location=$FILE.mp4 typefind=true ! video/quicktime !
aiurdemux ! v4l2h264dec ! queue ! v4l2h264enc ! [h264parse] ! matroskamux !
filesink location=$FILE.mkv
```

#### Note:

- For some mux, such as matroskamux, add h264parse/h265parse before mux.
- For i.MX 6, h264parse is not required, because the VPU can output AVC and byte-stream formats. For i.MX 8 and i.MX 95, h264parse/h265parse should be added before some mux, because the VPU supports only the byte-stream output.

### 7.3.5 Audio recording

Audio recording from EARC or S/PDIF on i.MX 8M Plus.

Since Multimedia version 4.7.0, PCM and compressed format eARC recording pipeline are unified into the following commandline:

```
gst-launch-1.0 -v alsasrc provide-clock=false device=hw:1,0 ! spdifdemux !
decodebin ! playsink audio-sink="alsasink device=sysdefault:CARD=wm8960audio
buffer-time=40000 sync=false"
```

**Note:** The *imxaudioxcvr* card number is 1.

For backward compatibility, the following legacy pipelines are still supported:

For PCM format:

```
gst-launch-1.0 -v alsasrc device=sysdefault:CARD=imxaudioxcvr ! audio/
x-raw,format=S16LE,channels=2,rate=48000 ! playsink audio-sink="alsasink
device=sysdefault:CARD=wm8960audio buffer-time=40000"
```

For compressed format:

```
gst-launch-1.0 alsasrc device=sysdefault:CARD=imxaudioxcvr ! audio/x-raw,format=S16LE,channels=2,rate=48000 ! queue max-size-buffers=0 max-size-bytes=0 max-size-time=0 ! spdifdemux ! decodebin ! playsink audio-sink="alsasink device=sysdefault:CARD=wm8960audio buffer-time=40000 sync=false"
```

**Note:**

Run the following command to work in EARC mode:

```
amixer -c imxaudioxcvr cset numid=1,iface=MIXER,name='XCVR Mode' 'eARC'
```

The following examples show how to make an MP3 or WMA audio recording.

- MP3 recording

```
$GSTL pulsesrc num-buffers=$NUMBER blocksize=$SIZE ! lamemp3enc ! filesink location=output.mp3
```

**Note:**

The recording duration is calculated as  $\$NUMBER * \$SIZE * 8 / (\text{samplerate} * \text{channel} * \text{bit width})$ .

Therefore, to record 10 seconds of a stereo channel sample with a 44.1K sample rate and a 16 bit width, use the following command:

```
$GSTL pulsesrc num-buffers=430 blocksize=4096 ! 'audio/x-raw, rate=44100, channels=2' ! lamemp3enc ! filesink location=output.mp3
```

### 7.3.6 Video recording

Video recording is done using the camera input, so this activity only applies to platforms with a camera. Different cameras need to be set with different capture modes for special resolutions. See Chapter 14 "supporting cameras with CSI" and Chapter 15 "supporting cameras with MIPI-CSI" in the *i.MX BSP Porting Guide* (IMXBSPPG).

VPU video encoding only works on SoC with VPU encoder support. `imxv4l2src` is only supported on i.MX 6 and i.MX 7.

i.MX 8 and i.MX 9 supports opensource plugin `v4l2src` as camera source.

Use the `$GSTINSPECT` command to obtain more information about the codec property.

An example of recording might look like this:

```
$GSTL $V4L2SRC device=$DEVICE num-buffers=300 ! $INPUT_CAPS ! queue ! $video_encoder_plugin ! [h264parse] ! $MUXER ! filesink location=output.$EXTENSION
```

- `$V4L2SRC` can be `imxv4l2src`, or `v4l2src` according to the SoC.
- `$DEVICE` could be set to `/dev/video`, `/dev/video0`, or `/dev/video1` according to the system video input device.
- `$INPUT_CAPS` should be set to `video/x-raw,format=(string)NV12,width=1920,height=1080,framerate=(fraction)30/1`.
- `$MUXER` can be set to `qtmux`, `matroskamux`, `mp4mux`, `avimux`, or `flvmux`.

- `$EXTENSION` is filename extension according to the muxer type.

Refer to Section [Section 7.3.3](#) to choose the correct `$video_encoder_plugin`.

### 7.3.7 Audio/Video recording

This is an example of a command used to record audio and video together:

```
$GSTL -e $V4L2SRC device=$DEVICE ! $INPUT_CAPS ! queue ! $video_encoder_plugin !
[h264parse] ! queue ! mux. pulserc ! 'audio/x-raw, rate=44100, channels=2' !
lamemp3enc ! queue ! mux. $MUXER name=mux ! filesink location= output.
$EXTENSION
```

- `$V4L2SRC` can be `imxv4l2src` or `v4l2src` according to SoC.
- `$INPUT_CAPS` should be set to `video/x-raw, format=(string)NV12, width=1920, height=1080, framerate=(fraction)30/1`.
- `$MUXER` can be set to `qtmux`, `matroskamux`, `mp4mux`, `avimux`, or `flvmux`.

Refer to Section [Section 7.3.3](#) to choose the correct `$video_encoder_plugin`.

Common parameters are as follows:

- `-e` indicates to send EOS when the user presses **Ctrl+C** to avoid output corruption.
- `$EXTENSION` is the filename extension according to the multiplexer type.

### 7.3.8 Camera preview

This example displays what the camera sees. It is only available on platforms with a camera.

```
$GSTL v4l2src ! 'video/x-raw, format=(string)$FORMAT,
width=$WIDTH, height=$HEIGHT, framerate=(fraction)30/1'
! v4l2sink
```

Camera preview example:

```
$GSTL v4l2src device=/dev/video1 ! 'video/x-raw,
format=(string)UYVY,width=640,height=480,framerate=(fraction)30/1'
! autovideosink
```

Parameter comments:

- Get the camera support format and resolution using `gst-inspect-1.0 v4l2src`.
- Set caps filter according to the camera's supported capabilities if the user needs other format or resolution.
- Ensure that the right caps filter has been set, which also needs to be supported by `v4l2sink`.

### 7.3.9 Recording the TV-in source

The TV-in source plugin gets video frames from the TV decoder. It is based on the V4I2 capture interface. A command line example is as follows:

```
gst-launch-1.0 v4l2src ! autovideosink
```

#### Note:

*The TV decoder is ADV7180. It supports NTSC and PAL TV mode. The output video frame is interlaced, so the sink plugin needs to enable deinterlace. The default value of `v4l2sink deinterface` is `True`.*

### 7.3.10 Web camera

The following command line is an example of how to record and transfer web camera input.

```
$GSTL v4l2src device=/dev/video1 ! $video_encoder_plugin ! rtph264pay ! udpsink
host=$HOST_IP
```

HOST\_IP is the IP/multicast group to send the packets to.

This command line is an example of how to receive and display web camera input.

```
$GSTL udpsrc ! buffer-size=204800 (example number) application/x-rtp !
rtph264depay ! $video_decoder_plugin ! autovideosink
```

### 7.3.11 HTTP streaming

The HTTP streaming includes the following:

- Manual pipeline

```
$GSTL souphttpsrc location= http://SERVER/test.avi ! typefind
! aiurdemux name=demux demux. ! queue max-size-buffers=0 max-size-time=0
! $video_decoder_plugin ! $video_sink_plugin demux. ! queue max-size-
buffers=0 max-size-time=0
! beepdec ! $audio_sink_plugin
```

- PLAYBIN

```
$GSTL $PLAYBIN uri=http://SERVER/test.avi
```

- GPLAY

```
$GPLAY http://SERVER/test.avi
```

### 7.3.12 HTTP live streaming

The HLS streaming includes the following:

- PLAYBIN

```
$GSTL $PLAYBIN uri=http://SERVER/test.m3u8
```

- GPLAY

```
$GPLAY http://SERVER/test.m3u8
```

### 7.3.13 MPEG-DASH streaming

The MPEG-DASH streaming includes the following:

- PLAYBIN

```
$GSTL $PLAYBIN uri=http://SERVER/test.mpd
```

- GPLAY

```
$GPLAY http://SERVER/test.mpd
```

**Note:** Supports TS, MP4, and WebM container format segment currently.

### 7.3.14 Real Time Streaming Protocol (RTSP) playback

Use the following command to see the GStreamer RTP depacketize plugins:

```
$GSTINSPECT | grep depay
```

RTSP streams can be played with a manual pipeline or by using playbin. The format of the commands is as follows.

- Manual pipeline

```
$GSTL rtspsrc location=$RTSP_URI name=source
! queue ! $video_rtp_depacketize_plugin ! $vpu_dec ! $video_sink_plugin
source.
! queue ! $audio_rtp_depacketize_plugin ! $audio_parse_plugin ! beepdec !
$audio_sink_plugin
```

- PLAYBIN

```
$GSTL $PLAYBIN uri=$RTSP_URI
```

Two properties of `rtspsrc` that are useful for RTSP streaming are:

- **Latency:** This is the extra added latency of the pipeline, with the default value of 200 ms. If you need low-latency RTSP streaming playback, set this property to a smaller value.
- **Buffer-mode:** This property is used to control the buffering algorithm in use. It includes four modes:
  - None: Outgoing timestamps are calculated directly from the RTP timestamps, not good for real-time applications.
  - Slave: Calculates the skew between the sender and receiver and produces smoothed adjusted outgoing timestamps, good for low latency communications.
  - Buffer: Buffer packets between low and high watermarks, good for streaming communication.
  - Auto: Chooses the three modes above depending on the stream. This is the default setting.

To pause or resume the RTSP streaming playback, use a buffer-mode of slave or none for `rtspsrc`, as in `buffer-mode=buffer`. After resuming, the timestamp is forced to start from 0, and this causes buffers to be dropped after resuming.

Manual pipeline example:

```
$GSTL rtspsrc location=rtsp://10.192.241.11:8554/test name=source
! queue ! rtph264depay ! avdec_h264 ! overlaysink source.
! queue ! rtpmp4gdepay ! aacparse ! beepdec ! pulsesink
```

Playback does not exit automatically in GStreamer 1.x, if `buffer-mode` is set to `buffer` in the `rtspsrc` plugin.

### 7.3.15 RTP/UDP MPEGTS streaming

There are some points to keep in mind when doing RTP/UDP MPEGTS Streaming:

- The source file that the UDP/RTP server sends must be in TS format.
- Start the server one second earlier than the time client starts.
- Two properties of `aiurdemux` that are useful for UDP/RTP TS streaming are:
  - **streaming-latency:** This is the extra added latency of the pipeline, and the default value is 400 ms. This value is designed for the situation when the client starts first. If the value is too small, the whole pipeline may not run due to lack of audio or video buffers. In that situation, you should cancel the current command and restart the pipeline. If the value is too large, wait for a long time to see the video after starting the server.

**low\_latency\_tolerance:** This value is a range that total latency can jitter around streaming-latency. This property is disabled by default. When the user sets this value, the maximum latency is (streaming-latency + low\_latency\_tolerance).

The UDP MPEGTS streaming command line format looks like this:

```
$GSTL udpsrc do-timestamp=false uri=$UDP_URI caps="video/mpegts"
! aiurdemux streaming_latency=400 name=d d. ! queue ! $vpu_dec
! queue ! $video_render_sink sync=true d. ! queue ! beepdec !
$audio_sink_plugin sync=true
```

```
$GSTL udpsrc do-timestamp=false uri=udp://10.192.241.255:10000 caps="video/
mpegts"
! aiurdemux streaming_latency=400 name=d d. ! queue ! vpudec
! queue ! overlaysink sync=true d. ! queue ! beepdec ! pulsesink sync=true
```

The format for an RTP MPEGTS streaming command is covered as follows:

```
$GSTL udpsrc do-timestamp=false uri=$RTP_URI caps="application/x-rtp"
! rtpmp2tdepay ! aiurdemux streaming_latency=400 name=d d. ! queue !
$vpu_dec
! queue ! $video_render_sink sync=true d. ! queue ! beepdec !
$audio_sink_plugin sync=true
```

```
$GSTL udpsrc do-timestamp=false uri=udp://10.192.241.255:10000
caps="application/x-rtp"
! rtpmp2tdepay ! aiurdemux streaming_latency=400 name=d d.
! queue ! vpudec ! queue ! overlaysink sync=true d. ! queue ! beepdec
! pulsesink sync=true
```

### 7.3.16 RTSP streaming server

The RTSP streaming server use case is based on the open source `gst-rtsp-server` package. It uses the i.MX aiurdemux plugin to demultiplex the file to audio or video elementary streams and to send them out through RTP. Start the RTSP streaming server on one board, and play it on another board with the RTSP streaming playback commands.

The `gst-rtsp-server` package is not installed by default in the Yocto Project release. Follow these steps to build and install it.

1. Enable the layer `meta-openembedded/meta-multimedia`:  
Add the line `BBLAYERS += "${BSPDIR}/sources/meta-openembedded/meta-multimedia"` to the configuration file `$yocto_root/build/conf/bblayers.conf`.
2. Include `gst-rtsp-server` into the image build:  
Add the line `IMAGE_INSTALL:append = " gstreamer1.0-rtsp-server"` to the configuration file `$yocto_root/build/conf/local.conf`.
3. Run `bitbake` for your image to build with `gst-rtsp-server`.
4. You can find the `test-uri` binary in the folder:

```
$yocto_root/build/tmp/work/cortexa9hf-vfp-neon-poky-linux-gnueabi/
gstreamer1.0-rtsp-server/$version/
build/examples/
```

5. Flash the image.  
Copy `test-uri` into `/usr/bin` in the rootfs on your board and assign execute permission to it.

Some information on running the tool is as follows:

- Command:

```
test-uri $RTSP_URI
```

For example:

```
test-uri file:///home/root/temp/TestSource/mp4/1.mp4
```

- Server address:

```
rtsp://$SERVER_IP:8554/test
```

For example:

```
rtsp://10.192.241.106:8554/test
```

- Client operations supported are Play, Stop, Pause, Resume, and Seek.

### 7.3.17 Video conversion

There are four video conversion plugins, `imxvideoconvert_ipu`, `imxvideoconvert_g2d`, `imxvideoconvert_ocl`, and `imxvideoconvert_pxp`. All of them, except for `imxvideoconvert_ocl`, can be used to perform video color space conversion, resize, and rotate. `imxvideoconvert_ipu` can also be used to perform video deinterlacing. `imxvideoconvert_ocl` can be used to perform video color space conversion, color range conversion, and deinterlace. They can be used to connect before `ximagesink` to enable the video rendering on X Windows or used in transcoding to change video size, rotation, or deinterlacing.

`imxvideoconvert_ocl` supports the following conversions:

- RGBA32 to NV12, supports output buffer of BT601 and BT709, limited and full range.
- RGBX32 to NV12, supports output buffer of BT601 and BT709, limited and full range.
- NV12 to NV12, supports input and output buffer of BT601 and BT709, limited and full range.
- NV12 to RGB24, supports input buffer of BT601 and BT709, limited and full range.
- YUYV to RGB24, supports input buffer of BT601 and BT709, limited and full range.
- RGBA32 to RGB24.
- NV12TILE to NV12, only for Amphion VPU decoder, including deinterlace, full range to limited range.
- NV15TILE to NV12, only for Amphion VPU decoder, including deinterlace, full range to limited range.

Use `gst-inspect-1.0` to get each converter's capability and supported input and output formats. Note that `imxvideoconvert_g2d` can only perform color space converting to RGB space.

#### Color Space Conversion (CSC)

```
gst-launch-1.0 videotestsrc ! video/x-raw,format=NV12 ! imxvideoconvert_{xxx} !
video/x-raw,format=RGB16 ! ximagesink display=:0
```

#### Color Space Conversion (CSC) with OpenGL-based Converter

```
gst-launch-1.0 videotestsrc ! video/x-raw,format=RGBA ! imxvideoconvert_ocl !
video/x-raw,format=NV12 ! waylandsink
```

#### Color Range Conversion with OpenGL-based Converter

```
gst-launch-1.0 videotestsrc ! video/x-raw,format=NV12,colorimetry=1:3:0:0 !
imxvideoconvert_ocl ! video/x-raw,format=NV12,colorimetry=2:3:0:0 ! waylandsink
```



**Combine usage for G2D and OpenGL-based Converter**

```
gst-launch-1.0 videotestsrc ! video/x-raw,format=Nv12,width=1920,height=1080 !
  imxvideoconvert_g2d ! video/x-raw,width=300,height=300 ! imxvideoconvert_ocl !
  video/x-raw,format=RGB ! videoconvert ! waylandsink
```

**Resize**

```
gst-launch-1.0 videotestsrc ! video/x-raw,format=Nv12,width=800,height=600 !
  imxvideoconvert_{xxx} ! video/x-raw, width=640, height=480 ! ximagesink
  display=:0
```

**Rotate**

```
gst-launch-1.0 videotestsrc ! imxvideoconvert_{xxx} rotation=2 ! ximagesink
  display=:0
```

**Video crop with i.MX with G2D**

```
gst-launch-1.0 videotestsrc ! videocrop top=10 bottom=10 right=10 left=10 !
  imxvideoconvert_g2d videocrop-meta-enable=true ! queue ! ximagesink display=:0
```

**Deinterlacing with i.MX with IPU**

```
gst-launch-1.0 playbin uri=file://$FILE video-sink="imxvideoconvert_ipu
  deinterlace=3 ! ximagesink display=:0 sync=false"
```

**Transcoding with i.MX with VPU**

```
gst-launch-1.0 filesrc location=$FILE.mp4 typefind=true ! video/
  quicktime ! aiurdemux ! vpudec ! imxvideoconvert_ipu ! video/x-
  raw,format=Nv12,width=1280,height=720 ! vpuenc_h263 ! avimux ! filesink
  location=$FILE.avi
```

**Combination with i.MX with IPU or VPU**

It is possible to combine CSC, resize, rotate, and deinterlace at one time. Both `imxvideoconvert_ipu` and `imxvideoconvert_g2d` can be used at the same time in a pipeline. The following is an example:

```
gst-launch-1.0 videotestsrc ! video/x-
  raw,format=I420,width=1280,height=800,interlace-mode=interleaved !
  imxvideoconvert_ipu rotation=2 deinterlace=3 ! video/
  x-raw,format=Nv12,width=800,height=600 ! vpuenc_h264 !
  vpudec ! imxvideoconvert_g2d rotation=3 ! video/x-
  raw,format=RGB16,width=640,height=480 ! ximagesink sync=false display=:0
```

**7.3.18 Video composition**

`imxcompositor_g2d` uses corresponding hardware to accelerate video composition. It can be used to composite multiple videos into one. The video position, size, and rotation can be specified while composition. Video color space conversion is also performed automatically if input and output video are not same. Each video can be set to an alpha and z-order value to get alpha blending and video blending sequence.

Note that `imxcompositor_g2d` can only output RGB color space format. Use `gst-inspect-1.0` to get more detailed information, including the supported input and output video format.

- Composite two videos into one.

```
gst-launch-1.0 imxcompositor_{xxx} name=comp sink_1::xpos=160
sink_1::ypos=120 ! overlaysink videotestsrc ! comp.sink_0 videotestsrc !
comp.sink_1
```

- Composite two videos into one with red background color.

```
gst-launch-1.0 imxcompositor_{xxx} background=0x000000FF name=comp
sink_1::xpos=160 sink_1::ypos=120 ! overlaysink videotestsrc ! comp.sink_0
videotestsrc ! comp.sink_1
```

- Composite two videos into one with CSC, resize, and rotate.

```
gst-launch-1.0 imxcompositor_{xxx} name=comp sink_0::width=640
sink_0::height=480
sink_1::xpos=160 sink_1::ypos=120 sink_1::width=640 sink_1::height=480
sink_1::rotate=1 !
video/x-raw,format=RGB16 ! overlaysink videotestsrc !
video/x-raw,format=NV12,width=320,height=240 ! comp.sink_0 videotestsrc !
video/x-raw,format=I420,width=320,height=240 ! comp.sink_1
```

- Composite three videos into one with CSC, resize, rotate, alpha, z-order, and keep aspect ratio.

```
gst-launch-1.0 imxcompositor_{xxx} name=comp sink_0::width=640
sink_0::height=480
sink_0::alpha=0.5 sink_0::z-order=3 sink_1::alpha=0.8 sink_1::z-order=2
sink_1::xpos=160
sink_1::ypos=120 sink_1::width=640 sink_1::height=480 sink_1::rotate=1
sink_2::xpos=320
sink_2::ypos=240 sink_2::width=500 sink_2::height=500 sink_2::alpha=0.6
sink_2::keep-ratio=true ! video/x-raw,format=RGB16 ! overlaysink
videotestsrc !
video/x-raw,format=NV12,width=320,height=240 ! comp.sink_0 videotestsrc !
video/x-raw,format=I420,width=320,height=240 ! comp.sink_1 videotestsrc !
video/x-raw,format=RGB16,width=320,height=240 ! comp.sink_2
```

## 7.4 PipeWire input/output settings

This section provides the instructions and commands for PipeWire.

### 7.4.1 PipeWire settings

This section provides the steps for PipeWire settings.

**Note:** Make sure to start the PipeWire, WirePlumber, and PipeWire-pulse services at first:

```
systemctl --user --now enable pipewire wireplumber pipewire-pulse
```

1. Use the `wpctl status` command to list all the available audio sinks and sources:

```
$ wpctl status
```

A list of available audio sinks/sources is displayed:

```
Audio
├── Devices:
│   ├── 36. Built-in Audio [alsa]
│   ├── 37. Built-in Audio [alsa]
│   └── 38. Built-in Audio [alsa]
```

```

39. Built-in Audio [alsa]
├── Sinks:
│   ├── 40. Built-in Audio Mono [vol: 0.40]
│   ├── * 42. Built-in Audio Analog Surround 5.1 [vol: 0.40]
│   └── 45. Built-in Audio Digital Stereo (IEC958) [vol: 0.40]
├── Sink endpoints:
├── Sources:
│   ├── 41. Built-in Audio Mono [vol: 1.00]
│   ├── * 43. Built-in Audio Analog Surround 5.1 [vol: 1.00]
│   ├── 44. Built-in Audio Stereo [vol: 1.00]
│   └── 46. Built-in Audio Digital Stereo (IEC958) [vol: 1.00]
├── Source endpoints:
└── Streams:

```

2. Use `wpctl inspect <object-id>` to display the information about the specified object. For example, `wpctl inspect 36` can check this audio card information.
3. Use `wpctl set-default <object-id>` to set the default audio sink and source according to the ID number of sinks or sources in the list shown above.

**Multichannel output support settings**

For those boards that need to output multiple channels, perform the following steps to enable the multichannel output profile:

1. Use `pw-cli info <object-id>` to find `<param-id>` of EnumProfile.

```

*      params: (4)
*      8 (Spa:Enum:ParamId:EnumProfile) r-
*      9 (Spa:Enum:ParamId:Profile) rw
*     12 (Spa:Enum:ParamId:EnumRoute) r-
*     13 (Spa:Enum:ParamId:Route) rw

```

Here, **8** is the `<param-id>` of EnumProfile.

2. Use `pw-cli enum-params <object-id> <param-id>` to check the profile index of the card. Here, `<object-id>` is the ID number of audio devices shown by `wpctl status`.

```

...
Object: size 464, type Spa:Pod:Object:Param:Profile (262151), id
Spa:Enum:ParamId:EnumProfile (8)
  Prop: key Spa:Pod:Object:Param:Profile:index (1), flags 00000000
        Int 3
  Prop: key Spa:Pod:Object:Param:Profile:name (2), flags 00000000
        String "output:analog-surround-71+input:analog-surround-51"
  Prop: key Spa:Pod:Object:Param:Profile:description (3), flags 00000000
        String "Analog Surround 7.1 Output + Analog Surround 5.1 Input"
...

```

Here, **3** is the profile index.

3. Use `wpctl set-profile <object-id> <profile index>` to set the profile for particular features.
4. Use `pw-play xx.wav` to play a multichannel wave file.

**7.5 Installing gstreamer1.0-libav into rootfs**

The following steps show how to install `gstreamer1.0-libav` into a rootfs image.

1. Add the following lines into the configuration file `conf/local.conf`.

```
IMAGE_INSTALL:append = " gstreamer1.0-libav"  
LICENSE_FLAGS_ACCEPTED = "commercial"
```

2. Build `gstreamer1.0-libav`.

```
$ bitbake gstreamer1.0-libav
```

3. Build the rootfs image.

```
$ bitbake <image_name>
```

## 8 Audio

### 8.1 DSP support

DSP support is provided on specific i.MX 8QuadXPlus, i.MX 8QuadMax, and i.MX 8M Plus SoC.

#### 8.1.1 HiFi 4 DSP framework

Supporting HiFi 4 on a custom board is documented in the *i.MX DSP User's Guide* (IMXDSPUG).

#### 8.1.2 Sound Open Firmware

Sound Open Firmware is an open source alternative to HiFi 4 DSP framework. For supporting the HiFi 4 on a custom board, see the SOF project documentation <https://thesofproject.github.io> available in the public domain.

For details about toolchains, supported platforms, binary packaging, and quick setup of audio scenarios, see [SOF User Guide on NXP i.MX 8 platforms](#).

### 8.2 HDMI eARC support

eARC is supported on the i.MX 8M Plus EVK board.

The procedure enables audio, which is input through the `imxaudioxcvr` card and played back through the `wm8960audio` card.

Make sure there is a headset plugged into the i.MX 8M Plus EVK audio jack. The procedure is as follows:

1. On i.MX 8M Plus EVK, set eARC mode. The default mode is SPDIF:

```
amixer -c 0 cset numid=1 2
```

2. On i.MX 8M Plus EVK, use `alsamixer` to set Headphone and Playback controls to the maximum values for the `wm8960-audio` card.
3. On i.MX 8M Plus EVK, start audio recording on the `imxaudioxcvr` card and playback on the `wm8960audio` card.

```
arecord -Dsysdefault:CARD=imxaudioxcvr -c2 -r48000 -fs32_LE -twav | aplay -  
Dsysdefault:CARD=wm8960audio
```

4. Make sure Digital Audio Out from the TV is PCM. Then, set eARC mode to **ON** and check audio on the headset connected to the i.MX 8M Plus EVK jack. The settings on the TV should be as shown in the following figure.

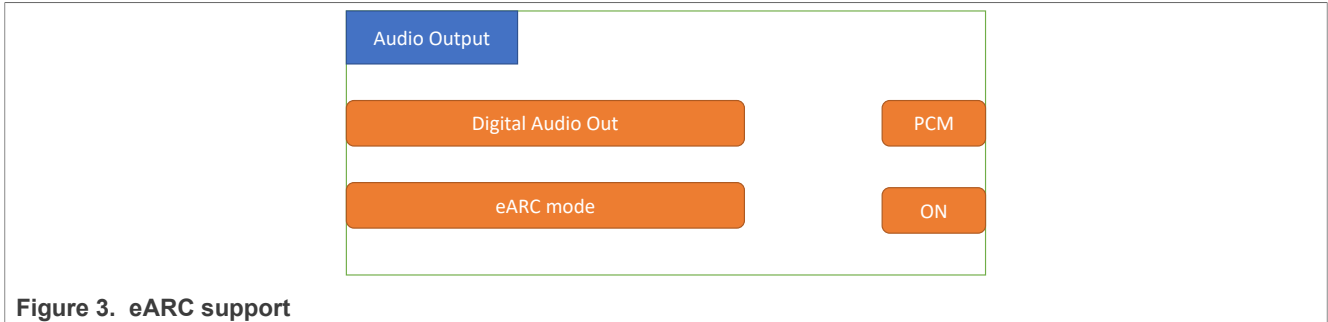

Figure 3. eARC support

**Note:** The procedure has been tested on Sony and LG TV.

The firmware on the eARC RX (i.MX 8M Plus EVK) waits until `HPD=high` is sensed. Therefore, start recording and playback on i.MX 8M Plus before enabling eARC mode on the TV as described in Steps 3 and 4 above. This makes the behavior more predictable on the RX side. In addition, set the subsequent eARC mode to **OFF** then to **ON** on the TV while keeping `arecord ... | aplay ...` running on i.MX 8M Plus EVK. Check whether you can hear audio in the headset after subsequent eARC mode is set to **ON** on the TV.

Besides, enabling the complete eARC feature, per the HDMI 2.1 specification, is more of a system-level application that integrates different layers and modules of the CEC driver, DRM, HDMI/ HDCP controller driver, EDID, and eARC driver modules.

### 8.3 Low power voice UI

#### 8.3.1 Introduction

The Cortex-M core on the i.MX 8M Plus, i.MX 8M Mini and i.MX 93 platforms can be used in an Asymmetric Multiprocessing (AMP) architecture for a low power voice User Interface (UI) solution.

The voice activity detection and wake work engine shall use the lowest power core of the i.MX 8M and i.MX 93, so that the Cortex-A cluster and related peripherals can remain in sleep mode for most of the “active listening” time.

Upon successful detection of a wake word, the Cortex-M core shall wake up the Cortex-A domain for better acoustic performance and further voice processing.

There are three components needed for this solution:

- Audio Front End (AFE)
- Linux drivers
- Cortex-M Image

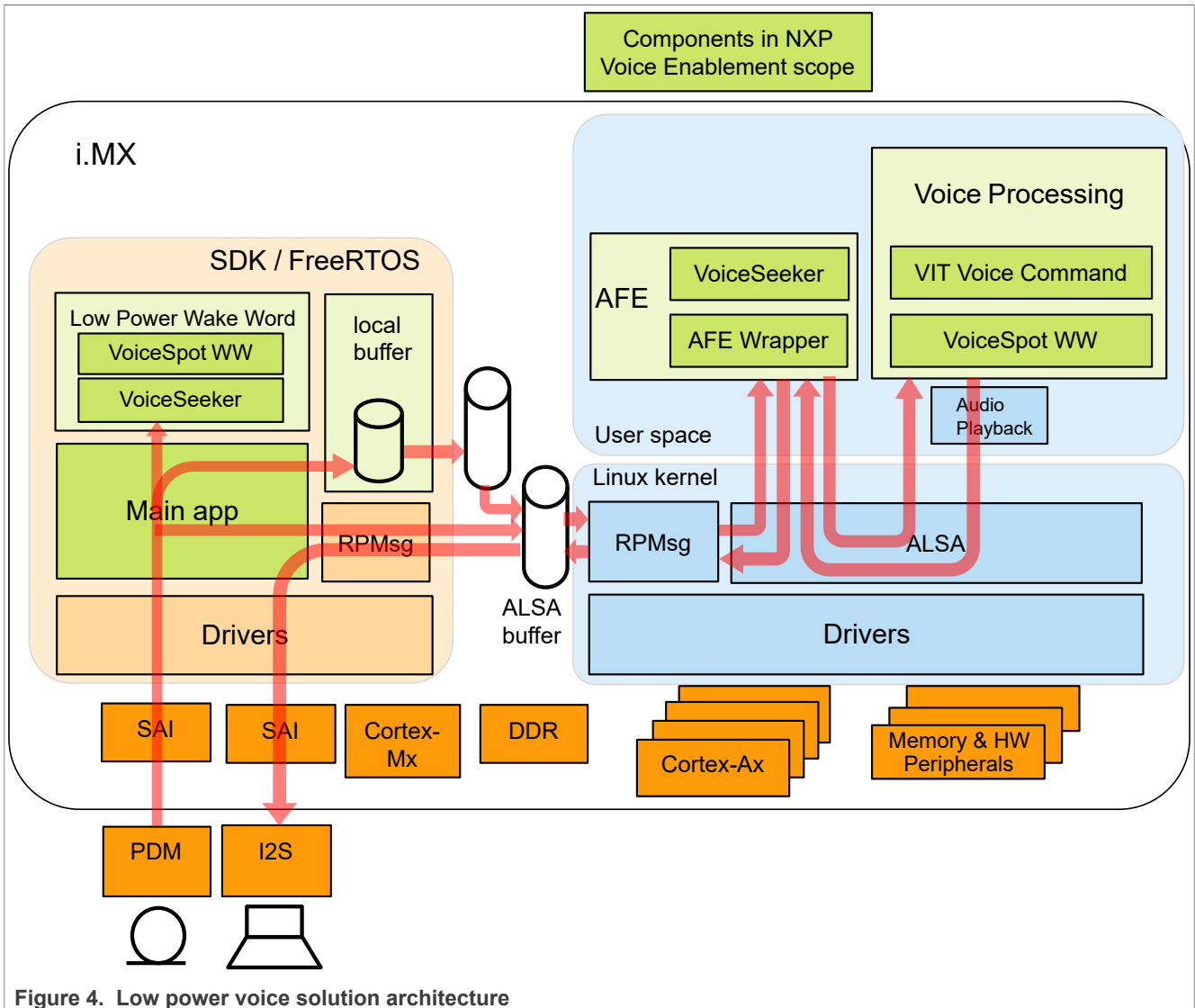

Figure 4. Low power voice solution architecture

### 8.3.2 Standard voice solution

In addition to the low power voice UI solution described in the previous section, a standard voice solution is also available. This solution does not leverage a Cortex-M image and therefore takes the microphone and speaker inputs/outputs directly from the Linux kernel (through drivers and the ALSA library). It also leverages VIT wake word detection engine (in place of VoiceSpot in the low power voice UI solution).

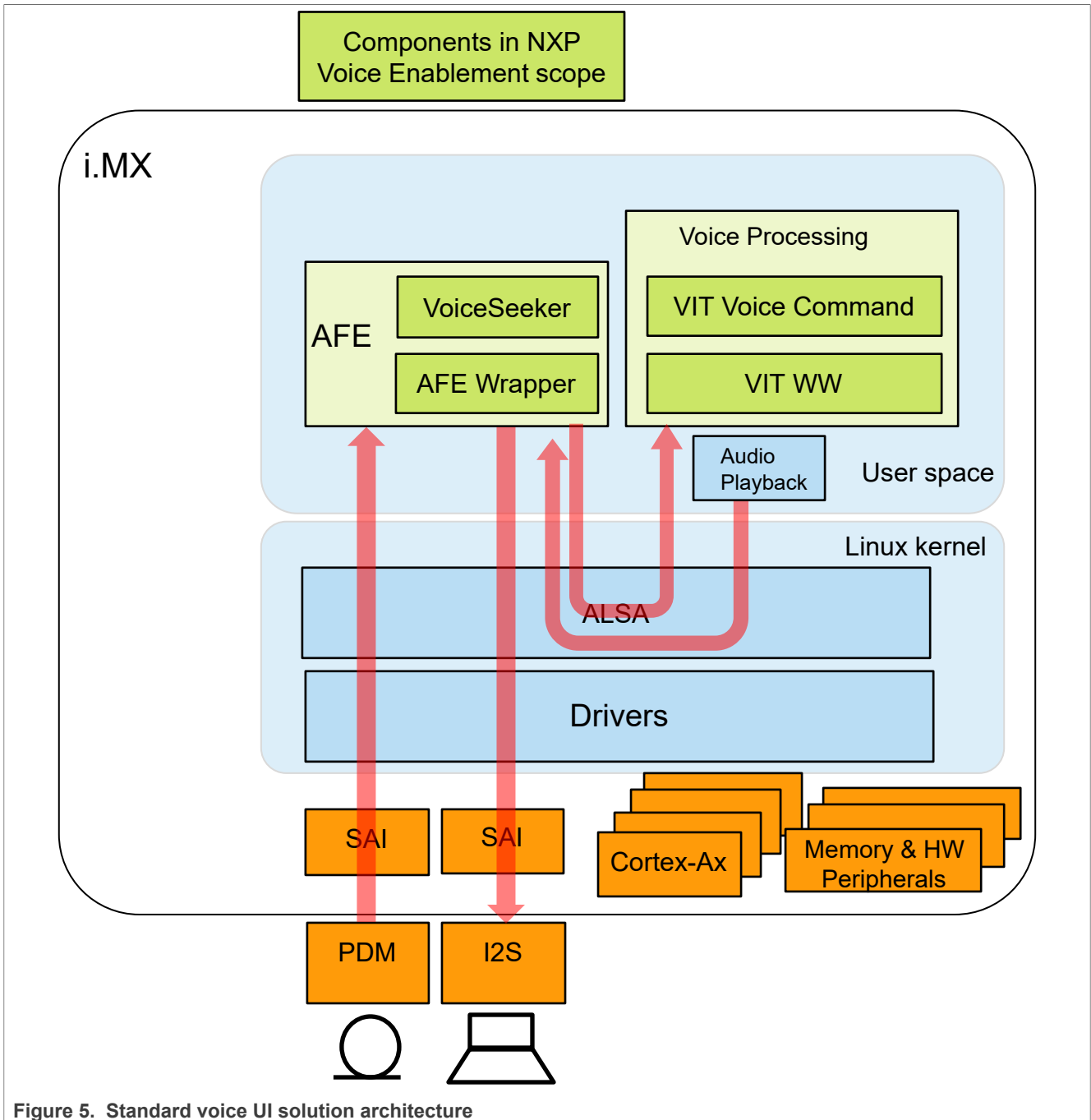

Figure 5. Standard voice UI solution architecture

### 8.3.3 Audio Front End (AFE)

To precisely detect human language, the audio signal from the microphone must be clean, without echo, noise, or other disturbances. To achieve this, a microphone array is typically used, with multiple, (usually) interleaved microphone signals input to the embedded device. Such a compound signal is then fed into a signal processor (commonly known as an Audio Front End), which filters out the noise, echo, and other disturbances. The output from the signal processor is then the desired single channel, clean microphone audio, which is used for further processing (wake-word detection and natural language processing).

To interface audio with the Linux OS, the Advanced Linux Sound Architecture (ALSA) library is used. The following figure shows the audio architecture.

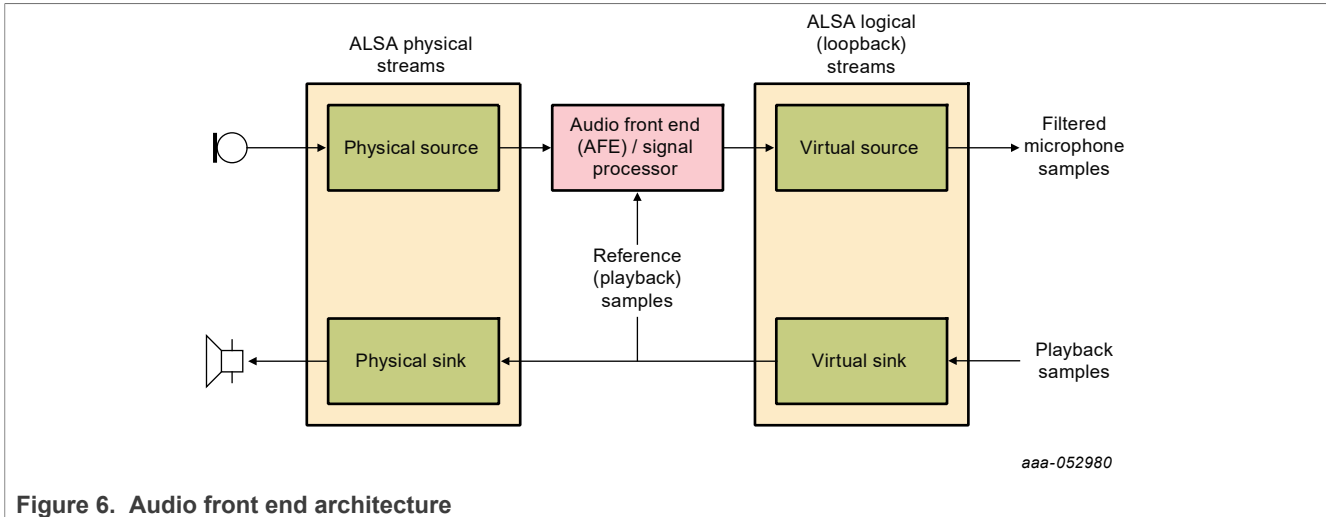

Figure 6. Audio front end architecture

The AFE code is on GitHub: <https://github.com/nxp-imx/nxp-afe/>. Use the Git tag corresponding to the current Linux BSP release.

The AFE deliveries are in Yocto `rootfs/unit_tests/nxp-afe/` and `/usr/lib/nxp-afe/`.

- `/unit_tests/nxp-afe/afe`: The main application of the AFE
- `/unit_tests/nxp-afe/TODO.md`: User guide document
- `/unit_tests/nxp-afe/asound.conf_imx8mm`: Used for i.MX 8M Mini default and RPMsg dtb
- `/unit_tests/nxp-afe/asound.conf_imx8mp`: Used for i.MX 8M Plus default and RPMsg dtb
- `/unit_tests/nxp-afe/asound.conf_imx8mp_revb4`: Used for i.MX 8M Plus EVKB4 default and RPMsg dtb
- `/unit_tests/nxp-afe/asound.conf_imx93`: Used for i.MX 93 default and RPMsg dtb for both EVK and QSB boards

In addition to the AFE, the Yocto BSP integrates VoiceSeeker (a multi-microphone voice control audio front-end signal processing solution), VoiceSpot (a small memory and MIPS profile wake word engine supporting the "Hey NXP" voice trigger word), and VIT for local voice command recognition. These deliveries are available on GitHub: <https://github.com/nxp-imx/imx-voiceui>. This contains:

- `VoiceSeeker_wrapper` folder contains the code used for generating the shared library used by the AFE wrapper. Check the `TODD.md` in the `nxp-afe` repository.
- `Voice_UI_Test_app` folder contains the code used for generating the voice UI application called "voice\_ui\_app". This application contains the VoiceSpot wake-word engine and VIT for local voice command recognition. This application uses the output of the AFE for voice detection (wake-word and voice commands).

See the README file in this GitHub repository, which explains how to build the VoiceSeeker library and the Voice UI Test application. Once these are built, the user shall copy the following files to Yocto rootfs:

- Copy `release/Config.ini` to `/unit_tests/nxp-afe/`.
- Copy `release/HeyNXP_1_params.bin` to `/unit_tests/nxp-afe/`.
- Copy `release/HeyNXP_en-US_1.bin` to `/unit_tests/nxp-afe/`.
- Copy `release/libvoiceseekerlight.so.2.0` to `/usr/lib/nxp-afe/libvoiceseekerlight.so.2.0`, symbol link `libvoiceseekerlight.so` to `libvoiceseekerlight.so.2.0`.



- Copy release/voice\_ui\_app to /unit\_tests/nxp-afe/.

```
root@imx8mpevk:/unit_tests/nxp-afe# ls -l
-rw-r--r-- 1 weston weston    294 Mar  9 2018 Config.ini
-rw-r--r-- 1 weston weston     56 Mar  9 2018 HeyNXP_1_params.bin
-rw-r--r-- 1 weston weston   32812 Mar  9 2018 HeyNXP_en-US_1.bin
-rw-r--r-- 1 weston weston   4130 Mar  9 2018 TODO.md
-rwxr-xr-x 1 weston weston   67752 Mar  9 2018 afe
-rw-r--r-- 1 weston weston   1642 Mar  9 2018 asound.conf_imx8mm
-rw-r--r-- 1 weston weston   1661 Mar  9 2018 asound.conf_imx8mp
-rw-r--r-- 1 weston weston   1660 Mar  9 2018 asound.conf_imx8mp_revb4
-rw-r--r-- 1 weston weston   1642 Mar  9 2018 asound.conf_imx93
-rwxr-xr-x 1 weston weston 3414200 Mar  9 2018 voice_ui_app
```

```
root@imx8mpevk:/usr/lib/nxp-afe# ls -l
lrwxrwxrwx 1 weston weston    19 Mar  9 2018 libdummyimpl.so ->
libdummyimpl.so.1.0
-rw-r--r-- 1 weston weston  67576 Mar  9 2018 libdummyimpl.so.1.0
lrwxrwxrwx 1 weston weston    26 Mar  9 2018 libvoiceseekerlight.so ->
libvoiceseekerlight.so.2.0
-rw-r--r-- 1 weston weston 331104 Mar  9 2018 libvoiceseekerlight.so.2.0
```

After this, follow the steps in /unit\_tests/nxp-afe/TODO.md to perform a test. The typical test method is as follows:

- ./voice\_ui\_app &
- ./afe libvoiceseekerlight &
- aplay test.wav &
- arecord -d10 -fS32\_LE -r16000 -c1 voiceseeker\_afe\_on.wav

The voice\_ui\_app binary enables the following VIT commands:

- MUTE
- NEXT
- SKIP
- PAIR DEVICE
- PAUSE
- STOP
- POWER OFF
- POWER ON
- PLAY MUSIC
- PLAY GAME
- WATCH CARTOON
- WATCH MOVIE

When users say "Hey NXP, power on", the "Hey NXP" wakes up the system, and the "power on" command is detected.

```
trigger = 2, trigger_sample = 0, start_sample = -12812, stop_sample = -812,
score = 28
keyword_start_offset_samples = 12812
ITER = 633
- Voice Command detected 8 POWER ON
```

There is a configuration file called `Config.ini` through which user can choose the wake-word engine, select the VIT language or implement other settings. It is a part of the standard voice solution.

```
$ cat /unit_tests/nxp-afe/Config.ini
[AFEConfig]
WWDetectionDisable = 0
WakeWordEngine = VoiceSpot
DebugEnable = 0
# Declare mic coordinates if not using default value for supported i.MX EVKs
#mic0 = 35.0, 15.15, 0.0
#mic1 = 17.5, -15.15, 0.0
#mic2 = -17.5, -15.15, 0.0
#mic3 = -35.0, 15.15, 0.0
VoiceSpotModel = HeyNXP_en-US_1.bin
VoiceSpotParams = HeyNXP_1_params.bin
VITLanguage = English
```

- `WWDetectionDisable`  
Disables/Enables the wake-word and command detection.
  - **0** - By default, enables the wake-word and command detection.
  - **1** - Disables wake-word and command detection. `voice_ui_app` does not work.
- `WakeWordEngine`  
This configuration depends on setting `WWDetectionDisable` to **0**. Selects if the `voice_ui_app` uses **VoiceSpot** or **VIT** for wake-word detection.
  - **VoiceSpot** - By default, use **VoiceSpot** to detect the wake-word.
  - **VIT** - Use **VIT** to detect wake-word.
- `DebugEnable`
  - **0** - By default, no debug recordings are made.
  - **1** - Enables recording the AFE input/output streams for debugging and tuning the `RefSignalDelay`.
- `RefSignalDelay`  
Used to calibrate the reference signal delay when using VoiceSeeker's Acoustic Echo Cancellation (AEC). The AEC enabled library is delivered with controlled access through Flexera. Please contact [voice@nxp.com](mailto:voice@nxp.com) for more information.
- `Mic coordinates`  
XYZ coordinates of the microphones in millimeters. The origin of the coordinate axis can be chosen as convenient. Users can set custom values if not using the default value for the supported i.MX EVKs.
- `VoiceSpotModel/VoiceSpotParams`  
The two parameters depend on setting `WakeWordEngine` to "VoiceSpot". They are used to specify the wake-word model and parameters used by **VoiceSpot**.
- `VITLanguage`  
This configuration depends on setting `WakeWordEngine` to "VIT". Selects the VIT language used to detect the wake-word and commands.
  - English - by default, uses English.
  - Mandarin - uses Mandarin.
  - Spanish - uses Spanish.
  - German - uses German.
  - Japanese - uses Japanese.
  - Korean - uses Korean.
  - Turkish - uses Turkish.
  - Italian - uses Italian.
  - French - uses French.

Notes on VIT model:

- VIT Wake-word and commands can be updated with generating new VIT Model thanks to the [VIT Model generation online tool](#).
- To have the new VIT Model considered by the application, the VIT model has be updated in `./vit/i.MX8M_A53/Lib/` or `/vit/i.MX9X_A55/Lib/` and `Voice_ui_app` recompiled.
- Same VIT model is used by the `Voice_ui_app` in low power or standard configuration. In the low power configuration, since VIT is used in voice commands mode only, VIT wake-word information is not considered by the VIT engine.

**Note:** For i.MX 93, the low power voice UI solution uses digital microphones and codec already mounted on the EVK. The add-on Audio hat is not supported.

### 8.3.4 Linux drivers

The primary Linux drivers used by the voice solutions are as follows:

- Loopback sound card: `sound/drivers/aloop.c`
- RPMsg sound card:
  - `sound/soc/fsl/fsl_rpmsg.c`
  - `sound/soc/fsl/imx-pcm-rpmsg.c`
  - `sound/soc/fsl/imx-rpmsg.c`

### 8.3.5 Cortex-M Image

#### 8.3.5.1 Application name

The Cortex-M application `low_power_wakeword` uses VoiceSeeker and VoiceSpot. When suspended, the Linux OS is resumed only when the “Hey NXP” wake-word is recognized.

This application is provided for i.MX 8M Mini, i.MX 8M Plus, and i.MX 93:

- `imx8mm_m4_TCM_low_power_wakeword.bin`
- `imx8mp_m7_TCM_low_power_wakeword.bin`
- `imx93-11x11-evk_m33_TCM_low_power_wakeword.bin`
- `imx93-9x9-qsb_m33_TCM_low_power_wakeword.bin`

#### 8.3.5.2 Board setup

To set up the board, perform the following steps:

1. Ensure the appropriate Cortex-M application is copied to the “boot” partition of your SD Card. The `low_power_wakeword` application should already exist from the public Yocto builds.
2. Boot the board, stop in U-Boot prompt, and run the commands below:
  - a. Chose the appropriate device tree:

- i.MX 8M Mini:

```
setenv fdtfile imx8mm-evk-rpmsg-wm8524-lpv.dtb
```

- i.MX 8M Plus:

```
setenv fdtfile imx8mp-evk-rpmsg-lpv.dtb
```

- i.MX 93 EVK:

```
setenv fdtfile imx93-11x11-evk-rpmsg-lpv.dtb
```

- i.MX 93 QSB:

```
setenv fdtfile imx93-9x9-qsb-rpmsg-lpv.dtb
```

- Load the Cortex-M image from Flash to TCM and boot the core before booting the Linux OS.

- i.MX 8M Mini and i.MX 8M Plus:

```
setenv lpv 'fatload mmc 1:1 0x48000000 <application_name>; cp.b
0x48000000 0x7e0000 0x40000; bootaux 0x7e0000;'
setenv bootcmd 'prepare_mcore;run lpv; '${bootcmd}
```

- i.MX 93 EVK and QSB:

```
setenv lpv 'fatload mmc 1:1 0x80000000 <application_name>; cp.b
0x80000000
0x201e0000 0x20000; bootaux 0x1ffe0000 0;'
setenv bootcmd 'run lpv; '${bootcmd}
setenv mmcargs 'setenv bootargs ${jh_clk} console=${console} root=
${mmcroot} clk-imx93.mcore_booted snd_pcm.max_alloc_per_card=134217728'
```

- Save the changes above.

```
saveenv
```

- Reboot the board, and the Cortex-M will be automatically started before the Linux OS. This can be checked on the Cortex-M console.
- Apply the appropriate ALSA configuration. After the Linux OS has booted, from the console:

- i.MX 8M Mini:

```
cp /unit_tests/nxp-afe/asound.conf_imx8mm /etc/asound.conf
```

- i.MX 8M Plus:

```
cp /unit_tests/nxp-afe/asound.conf_imx8mp /etc/asound.conf
```

- i.MX 93 EVK and QSB:

```
cp /unit_tests/nxp-afe/asound.conf_imx93 /etc/asound.conf
```

- Reboot to apply the changes above.

- Before starting any audio application, e.g., arecord, aplay, afe, load the audio loopback driver. From a Linux OS console:

```
modprobe snd-aloop
```

### 8.3.5.3 Execution

Once started, users have no direct actions to control the Cortex-M application. It automatically executes appropriate actions according to the Linux state:

- **When Linux OS is active and an application is recording audio:** The Cortex-M application is acting as a data pump, getting audio data from the microphones and providing them to ALSA drivers through RPMsg.
- **When Linux OS is suspended while an application is recording audio:** Audio data are processed locally on Cortex-M (by VoiceSeeker/VoiceSpot). The data is also stored in a ring-buffer. Once voice or the wake-word is detected (depending on the application), the Linux OS is automatically resumed, data from the ring buffer is sent to ALSA (so the Linux OS also gets the wakeword), and then the data-pump is re-started.
- **Suspending Linux OS:** Cortex-M only has the possibility to resume the Linux OS, not to suspend it. Instead, the Linux OS should be suspended by user-space action (the decision to suspend cannot be based only

on voice. It should also consider all the other potential user applications running on the Linux OS). For test purposes, this can be forced by the user by entering the following command to the Linux console.

```
echo mem > /sys/power/state
```

### 8.3.6 Power consumption notes

- For i.MX 8M Plus and i.MX 8M Mini:  
These applications using the public Yocto release demonstrate the voice UI mechanism described above to suspend the Linux OS and wake up on voice activity or a wakeword, but they still have a much higher power consumption than expected.  
Some changes are required in both the Cortex-M application and the Yocto image to achieve as low as possible power consumption during the "Linux suspended" state. They are delivered with controlled access through Flexera. For more information, contact your NXP representative.
- For i.MX 93 EVK:  
The public Yocto release already contains power-optimized applications demonstrating very low power consumption in "Linux suspended" state.

### 8.3.7 Using Linux remoteproc (i.MX 93 only)

On i.MX 93, the `low_power_wakeword` application can be started on the Cortex-M core by using the Linux remoteproc driver (see [Section 4.7.4](#)). In this use case, the board setup described in [Section 8.3.5.2](#) is the same, except for Step b "Load Cortex-M image" that should be skipped.

Then, when Linux OS is running, users can load and start the `low_power_wakeword` application on Cortex-M with the following commands:

```
echo imx93-11x11-evk_m33_TCM_low_power_wakeword.elf > /sys/class/remoteproc/  
remoteproc0/firmware  
echo start > /sys/class/remoteproc/remoteproc0/state
```

Once started, the usage is the same as when the application is started by U-Boot.

If needed, users can also stop and restart remoteproc with the following commands:

```
echo stop > /sys/class/remoteproc/remoteproc0/state  
rmmod snd-soc-imx-rpmsg  
rmmod imx-pcm-rpmsg  
rmmod snd_soc_wm8962
```

```
echo start > /sys/class/remoteproc/remoteproc0/state  
modprobe snd_soc_wm8962  
modprobe imx-pcm-rpmsg  
modprobe snd-soc-imx-rpmsg
```

## 8.4 Conversa Integration

Conversa is a comprehensive full-duplex, hands-free telephony speech processing suite providing total control of uplink and downlink audio. Conversa-embedded multimicrophone, full-duplex voice processing delivers the ultimate in sound quality for speakerphone and headset applications.

The Conversa processing suite is integrated to the i.MX 8M Plus using the NXP Audio Front End (AFE) wrapper. The i.MX 8M Plus works as an external USB speaker and microphone with voice processing capability.

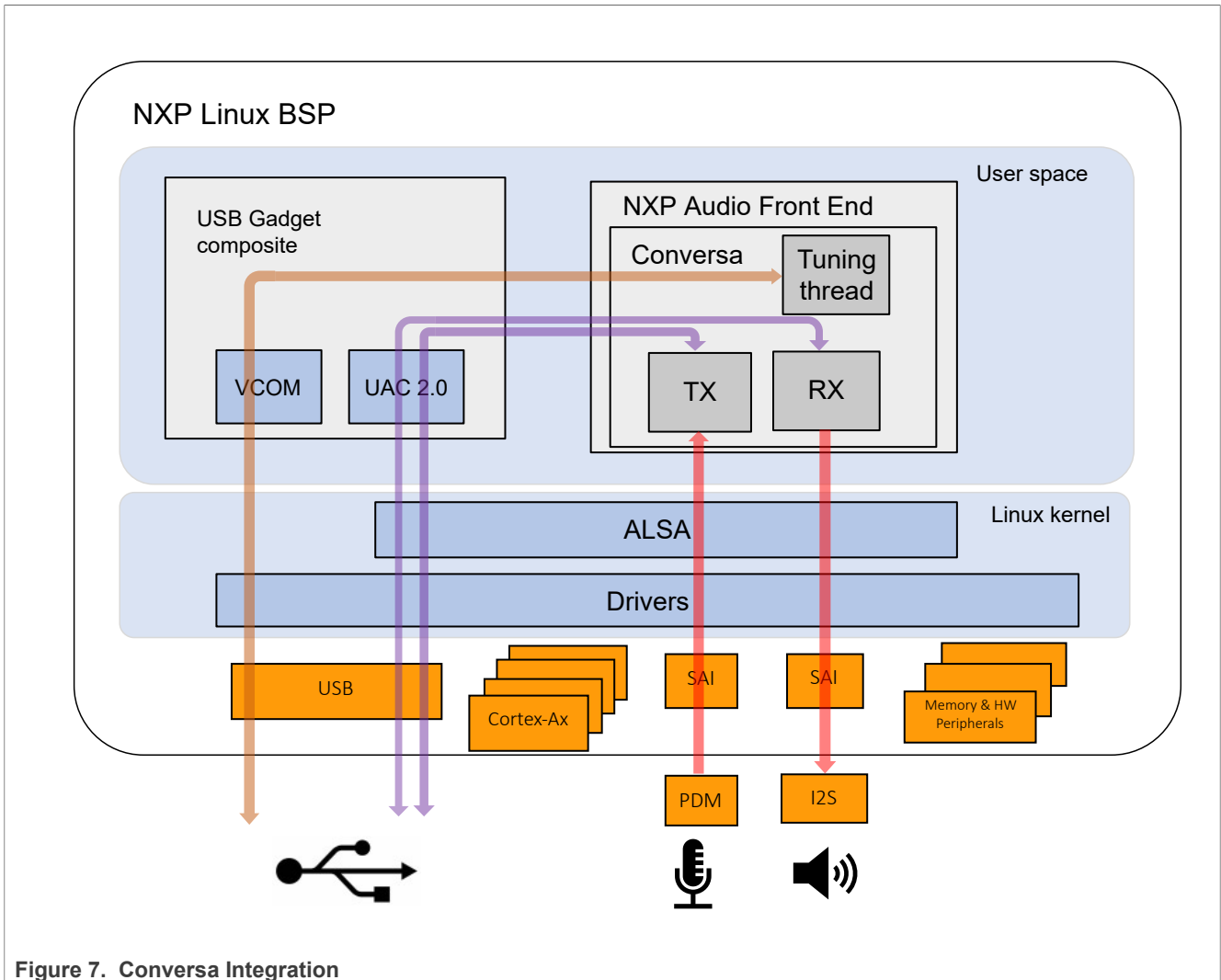

Figure 7. Conversa Integration

**Note:** The Conversa processing suite is a restricted-access solution. Contact your NXP representative for more details.

## 9 Graphics

There are a number of graphics tools, tests, and example programs that are built and installed in the Linux rootfs. There are some variation on what is included based on the build and packages selected, the board, and the backend specified. This section describes some of them.

The kernel module version of graphics used on the system can be found by running the following command on the board:

```
dmesg | grep Galcore
```

The user-side GPU drivers version of graphics can be displayed using the following command on the board:

```
grep VERSION /usr/lib/libGAL*
```

When reporting problems with graphics, this version number is needed.

## 9.1 imx-gpu-sdk

This graphics package contains source for several graphics examples for OpenGL ES 2.0 and OpenGL ES 3.0 APIs for X11, Framebuffer, and XWayland graphical backends. These applications show that the graphics acceleration is working for different APIs. The package includes samples, demo code, and documentation for working with the i.MX family of graphic cores. More details about this SDK are in the *i.MX Graphics User's Guide*. This SDK is only supported for hardware that has OpenGL ES hardware acceleration.

## 9.2 G2D-imx-samples

The G2D Application Programming Interface (API) is designed to make it easy to use and understand the 2D BLT functions. It allows the user to implement customized applications with simple interfaces. It is hardware and platform independent when using 2D graphics.

The G2D API supports the following features and more:

- Simple BLT operation from source to destination
- Alpha blend for source and destination with Porter-Duff rules
- High-performance memory copy from source to destination
- Up-scaling and down-scaling from source to destination
- 90/180/270 degree rotation from source to destination
- Horizontal and vertical flip from source to destination
- Enhanced visual quality with dither for pixel precision-loss
- High performance memory clear for destination
- Pixel-level cropping for source surface
- Global alpha blend for source only
- Asynchronous mode and synchronization
- Contiguous memory allocator
- VG engine

The G2D API document includes the detailed interface description and sample code for reference. The API is designed with C-Style code and can be used in both C and C++ applications.

The G2D is supported on all i.MX. The hardware that supports G2D is described below. For more details, see the Frame Buffer information in the *i.MX Release Notes* (IMXLXRN) to check which hardware is used for G2D.

- For i.MX 6 with GPU, the G2D uses the 2D GPU.
- For i.MX with PXP, the G2D uses the PXP with limited G2D features.

The following is the directory structure for the G2D test applications located under `/opt`.

- `g2d_samples`
  - `g2d_test`
    - `g2d_overlay_test`
    - `g2d_multiblitt_test`

## 9.3 viv\_samples

The directory `viv_samples` is found under `/opt`. It contains binary samples for OpenGL ES 1.1/2.0 and OpenVG 1.1.

The following are the basic sanity tests, which help to make sure that the system is configured correctly.

- cl11: This contains unit tests and FFT samples for OpenCL 1.1 Embedded Profile. OpenCL is implemented on the i.MX 6Quad, i.MX 6QuadPlus, and i.MX 8 boards.
  - UnitTest
    - clinfo
    - loadstore
    - math
    - threadwalker
    - test\_vivante
      - functions\_and\_kernels
      - illegal\_vector\_sizes
      - initializers
      - multi\_dimensional\_arrays
      - reserved\_data\_types
      - structs\_and\_enums
      - unions
      - unsupported\_extensions
  - fft
- es20: This contains tests for Open GLES 2.0.
  - vv\_launcher
    - coverflow.sh
    - vv\_launcher
- tiger: A simple OpenVG application with a rotating tiger head. This is to demonstrate OpenVG.
- vdk: Contains sanity tests for OpenGL ES 1.1 and OpenGL ES 2.0.

The tiger and VDK tests show that hardware acceleration is being used. They will not run without it.

## 9.4 Qt 6

Qt 6 is built into the Linux image in the Yocto Project environment with the command `bitbake imx-image-full`. For more details on Qt enablement, check out the README in the meta-imx repo and the *i.MX Yocto Project User's Guide* (IMXLXYOCTOUG).

## 10 Security

The i.MX platforms define a series of security acceleration subsystems.

### 10.1 CAAM kernel driver

#### 10.1.1 Introduction

The Linux kernel contains a Scatterlist Crypto API driver for the NXP CAAM security hardware block. It integrates seamlessly with in-kernel crypto users, such as DM-Crypt, Keyctl, in a way that any disk encryption and key management suites will automatically use the hardware to do the crypto acceleration. CAAM hardware is known in Linux kernel as 'caam', after its internal block name: Cryptographic Accelerator and Assurance Module.

There are several HW interfaces ("backends") that can be used to communicate (for example, submit requests) with the engine, their availability depends on the SoC:

- Register Interface (RI) - available on all SoCs (though access from kernel is restricted on DPAA2 SoCs).



Its main purpose is debugging (such as single-stepping through descriptor commands), though it is used also for RNG initialization.

- Job Ring Interface (JRI) - legacy interface, available on all SoCs; on most SoCs there are 4 rings.

**Note:**

There are cases when fewer rings are accessible or visible in the kernel, for example, when firmware like Trusted Firmware-A (TF-A) reserves one of the rings.

On top of these backends, there are the "frontends" - drivers that sit between the Linux Crypto API and backend drivers. Their main tasks aim to:

- Register supported crypto algorithms.
- Process crypto requests coming from users (through the Linux Crypto API) and translate them into the proper format understood by the backend being used.
- Forward the CAAM engine responses from the backend being used to the users.

To use a specific implementation, it is possible to ask for it explicitly by using the specific (unique) "driver name" instead of the generic "algorithm name". See official Linux Kernel Crypto API documentation (section Crypto API Cipher References And Priority). Currently, the default priority is 3000 for JRI frontend.

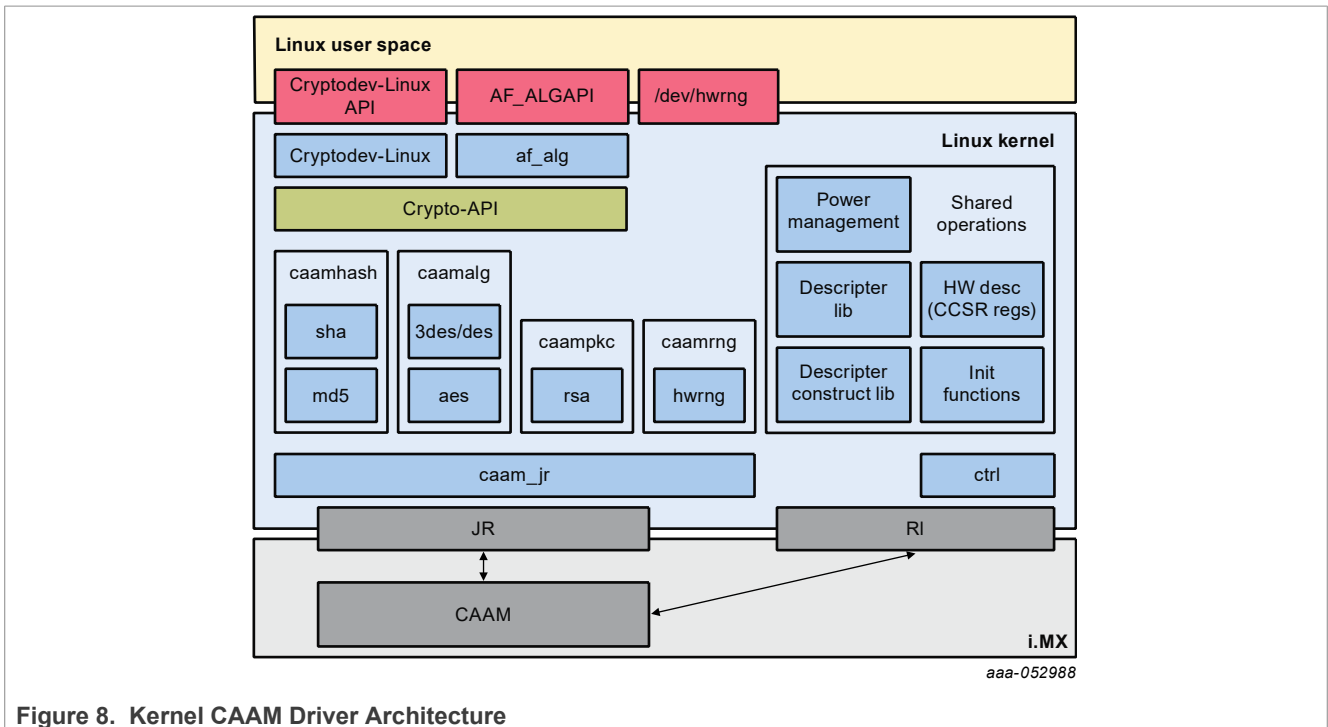

Figure 8. Kernel CAAM Driver Architecture

### 10.1.2 Source files

The drivers source code is maintained in the Linux kernel source tree, under `drivers/crypto/caam`. The following is a non-exhaustive list of files, mapping to CAAM (some files have been omitted because their existence is justified only by driver logic or design).

Table 75. Source files

Source File	Description	Module name
<code>ctrl.[c,h]</code>	Init (global settings, RNG, power management, etc.)	caam
<code>desc.h</code>	HW description (CCSR registers, etc.)	N/A

Table 75. Source files...continued

Source File	Description	Module name
desc_constr.h	Inline append - descriptor construction library	N/A
caamalg_desc.[c,h]	(Shared) Descriptors library (symmetric encryption, AEAD)	caamalg_desc
caamhash_desc.[c,h]	(Shared) Descriptors library (HASH)	caamhash_desc
caamrng.c	RNG (runtime)	N/A
caamkeyblob_desc.[c,h]	Descriptors library (black keys and blobs)	caamkeyblob_desc
jr.[c,h]	JRI backend	caam_jr
caamalg.c	JRI frontend (symmetric encryption, AEAD)	N/A
caamhash.c	JRI frontend (hashing)	N/A
caampkc.c, pkc_desc.c	JRI frontend (public key cryptography)	N/A
caamkeyblob.[c,h]	JRI frontend (black keys and blobs)	N/A
caamkeygen.c	IOCTL calls for key and blob generation/import	N/A

### 10.1.3 Module loading

CAAM backend drivers can be compiled either built-in or as modules. Frontend drivers are linked to the backend driver. See Section [Section 10.1.2](#) for the list of module names and Section [Section 10.1.4](#) for how kernel configuration looks like and a mapping between menu entries and modules and/or functionalities enabled.

### 10.1.4 Kernel configuration

The designated driver should be configured in the kernel by default for the target platform. If unsure, check CONFIG\_CRYPTO\_DEV\_FSL\_CAAM, which is located in the **Cryptographic API -> Hardware crypto devices** sub-menu in the kernel configuration.

Table 76. Kernel configuration tree view

Kernel configuration tree view option	Description
<pre> ---Cryptographic API ---&gt; [*]   Hardware crypto devices ---&gt; &lt;*&gt;CAAM/SNVS Security Violation Handler       (EXPERIMENTAL) &lt;*&gt;Freescale CAAM-Multicore platform driver       backend [ ]   Enable debug output in CAAM driver &lt;*&gt;   Freescale CAAM Job Ring driver backend       ---&gt; (9)   Job Ring size [ ]   Job Ring interrupt coalescing [*]   Register algorithm implementations       with the Crypto API [*]   Register hash algorithm       implementations with Crypto API [*]   Register public key cryptography       implementations with Crypto API [*]   Register caam device for hwrng API [*]   Register tagged key cryptography       implementations with Crypto API           </pre>	<p>Enable CAAM device driver:</p> <ul style="list-style-type: none"> <li>Basic platform driver: Freescale CAAM-Multicore platform driver backend</li> <li>Backends/interfaces: Freescale CAAM Job Ring driver backend - JRI</li> <li>Frontends/crypto algorithms: symmetric encryption, AEAD, "stitched" AEAD; Register algorithm implementations with the Crypto API - via JRI (caamalg driver)</li> <li>Register hash algorithm implementations with Crypto API - hashing (only via JRI - caamhash driver)</li> <li>Register public key cryptography implementations with Crypto API - asymmetric/public key (only via JRI - caampkc driver)</li> <li>Register CAAM device for hwrng API - HW RNG (only via JRI - caamrng driver)</li> </ul>

**Table 76. Kernel configuration tree view**

Kernel configuration tree view option	Description
<pre>[ ] Test caam rng [*] CAAM Secure Memory / Keystore API    (EXPERIMENTAL) (7) Size of each keystore slot in    Secure Memory &lt;M&gt; CAAM Secure Memory - Keystore Test/ Example (EXPERIMENTAL) &lt;M&gt; Freescale Job Ring UIO support</pre>	<ul style="list-style-type: none"> <li>Register algorithms supporting tagged key and generate black keys and encapsulate them into black blobs</li> </ul>

**Table 77. Device tree binding**

Property	Type	Status	Description
compatible	String	Required	fsl, sec-vX.Y (preferred) or fsl, secX.Y

**Sample Device Tree crypto node**

```
crypto@30000 {
    compatible = "fsl,sec-v4.0";
    fsl,sec-era = <2>;
    #address-cells = <1>;
    #size-cells = <1>;
    reg = <0x300000 0x10000>;
    ranges = <0 0x300000 0x10000>;
    interrupt-parent = <&mpic>;
    interrupts = <92 2>;
    clocks = <&clks IMX6QDL_CLK_CAAM_MEM>,
            <&clks IMX6QDL_CLK_CAAM_ACLK>,
            <&clks IMX6QDL_CLK_CAAM_IPG>,
            <&clks IMX6QDL_CLK_EIM_SLOW>;
    clock-names = "mem", "aclk", "ipg", "emi_slow";
};
```

**10.1.5 How to test the drivers**

Crypto drivers could be validated in two modes: at boot time and at request. To enable crypto testing feature, the kernel needs to be updated as follows.

**Table 78. Kernel configuration**

Kernel configuration	Description
<pre>--- Cryptographic API ---&gt; [ ] Disable run-time self tests [ ] Enable extra run-time crypto   self tests &lt;M&gt; Testing module</pre>	<p>Deselect the feature that bypass crypto driver validation. By default, Linux kernel is bypassing crypto driver validation. Disable run-time self tests that normally take place at algorithm registration.</p> <p>Enable extra run-time self tests of registered crypto algorithms, including randomized fuzz tests. This is intended for developer use only, as these tests take much longer to run than the normal self tests.</p> <p>Enable testing module.</p>

Section from boot log that specify where crypto test are made (If a boot test is passing with success, no information will be reported. For algorithms with no tests available, a line in dmesg will be printed):

```
[ 4.647985] alg: No test for authenc(hmac(sha224),ecb(cipher_null)) (authenc-hmac-sha224-ecb-cipher_null-caam)
[ 4.661181] alg: No test for authenc(hmac(sha256),ecb(cipher_null)) (authenc-hmac-sha256-ecb-cipher_null-caam)
[ 4.671345] alg: No test for authenc(hmac(sha384),ecb(cipher_null)) (authenc-hmac-sha384-ecb-cipher_null-caam)
[ 4.681486] alg: No test for authenc(hmac(sha512),ecb(cipher_null)) (authenc-hmac-sha512-ecb-cipher_null-caam)
[ 4.691608] alg: No test for authenc(hmac(md5),cbc(aes)) (authenc-hmac-md5-cbc-aes-caam)
[ 4.699802] alg: No test for echainiv(authenc(hmac(md5),cbc(aes))) (echainiv-authenc-hmac-md5-cbc-aes-caam)
[ 4.710445] alg: No test for echainiv(authenc(hmac(sha1),cbc(aes))) (echainiv-authenc-hmac-sha1-cbc-aes-caam)
[ 4.720488] alg: No test for authenc(hmac(sha224),cbc(aes)) (authenc-hmac-sha224-cbc-aes-caam)
[ 4.734647] alg: No test for echainiv(authenc(hmac(sha224),cbc(aes))) (echainiv-authenc-hmac-sha224-cbc-aes-caam)
[ 4.750504] alg: No test for echainiv(authenc(hmac(sha256),cbc(aes))) (echainiv-authenc-hmac-sha256-cbc-aes-caam)
[ 4.762468] alg: No test for authenc(hmac(sha384),cbc(aes)) (authenc-hmac-sha384-cbc-aes-caam)
[ 4.771188] alg: No test for echainiv(authenc(hmac(sha384),cbc(aes))) (echainiv-authenc-hmac-sha384-cbc-aes-caam)
[ 4.782380] alg: No test for echainiv(authenc(hmac(sha512),cbc(aes))) (echainiv-authenc-hmac-sha512-cbc-aes-caam)
[ 4.792765] alg: No test for authenc(hmac(md5),cbc(des3_ede)) (authenc-hmac-md5-cbc-des3_ede-caam)
[ 4.801832] alg: No test for echainiv(authenc(hmac(md5),cbc(des3_ede))) (echainiv-authenc-hmac-md5-cbc-des3_ede-caam)
[ 4.812814] alg: No test for echainiv(authenc(hmac(sha1),cbc(des3_ede))) (echainiv-authenc-hmac-sha1-cbc-des3_ede-caam)
[ 4.823942] alg: No test for echainiv(authenc(hmac(sha224),cbc(des3_ede))) (echainiv-authenc-hmac-sha224-cbc-des3_ede-caam)
[ 4.835465] alg: No test for echainiv(authenc(hmac(sha256),cbc(des3_ede))) (echainiv-authenc-hmac-sha256-cbc-des3_ede-caam)
[ 4.846980] alg: No test for echainiv(authenc(hmac(sha384),cbc(des3_ede))) (echainiv-authenc-hmac-sha384-cbc-des3_ede-caam)
[ 4.858497] alg: No test for echainiv(authenc(hmac(sha512),cbc(des3_ede))) (echainiv-authenc-hmac-sha512-cbc-des3_ede-caam)
[ 4.869764] alg: No test for authenc(hmac(md5),cbc(des)) (authenc-hmac-md5-cbc-des-caam)
[ 4.877977] alg: No test for echainiv(authenc(hmac(md5),cbc(des))) (echainiv-authenc-hmac-md5-cbc-des-caam)
[ 4.888078] alg: No test for echainiv(authenc(hmac(sha1),cbc(des))) (echainiv-authenc-hmac-sha1-cbc-des-caam)
[ 4.898356] alg: No test for echainiv(authenc(hmac(sha224),cbc(des))) (echainiv-authenc-hmac-sha224-cbc-des-caam)
[ 4.908994] alg: No test for echainiv(authenc(hmac(sha256),cbc(des))) (echainiv-authenc-hmac-sha256-cbc-des-caam)
[ 4.919653] alg: No test for echainiv(authenc(hmac(sha384),cbc(des))) (echainiv-authenc-hmac-sha384-cbc-des-caam)
[ 4.930292] alg: No test for echainiv(authenc(hmac(sha512),cbc(des))) (echainiv-authenc-hmac-sha512-cbc-des-caam)
[ 4.940688] alg: No test for authenc(hmac(md5),rfc3686(ctr(aes))) (authenc-hmac-md5-rfc3686-ctr-aes-caam)
```

```
[ 4.950372] alg: No test for seqiv(authenc(hmac(md5),rfc3686(ctr(aes))))
(seqiv-authenc-hmac-md5-rfc3686-ctr-aes-caam)
[ 4.961281] alg: No test for seqiv(authenc(hmac(sha1),rfc3686(ctr(aes))))
(seqiv-authenc-hmac-sha1-rfc3686-ctr-aes-caam)
[ 4.972281] alg: No test for authenc(hmac(sha224),rfc3686(ctr(aes)))
(authenc-hmac-sha224-rfc3686-ctr-aes-caam)
[ 4.982482] alg: No test for seqiv(authenc(hmac(sha224),rfc3686(ctr(aes))))
(seqiv-authenc-hmac-sha224-rfc3686-ctr-aes-caam)
[ 4.993903] alg: No test for seqiv(authenc(hmac(sha256),rfc3686(ctr(aes))))
(seqiv-authenc-hmac-sha256-rfc3686-ctr-aes-caam)
[ 5.005331] alg: No test for seqiv(authenc(hmac(sha384),rfc3686(ctr(aes))))
(seqiv-authenc-hmac-sha384-rfc3686-ctr-aes-caam)
[ 5.016763] alg: No test for seqiv(authenc(hmac(sha512),rfc3686(ctr(aes))))
(seqiv-authenc-hmac-sha512-rfc3686-ctr-aes-caam)
[ 5.028023] caam algorithms registered in /proc/crypto
[ 5.157622] caam_jr 31430000.jr2: registering rng-caam
[ 5.206167] caam_31400000.caam: caam pkc algorithms registered in /proc/
crypto
```

## 10.2 Crypto algorithms support

- Algorithms supported in the Linux kernel scatterlist Crypto API
 

The Linux kernel contains various users of the Scatterlist Crypto API, including its IPsec implementation, sometimes referred to as the NETKEY stack. The driver, after registering supported algorithms with the Crypto API, is therefore used to process per packet symmetric crypto requests and forward them to the CAAM hardware. Since CAAM hardware processes requests asynchronously, the driver registers asynchronous algorithm implementations with the crypto API: `ahash`, `skcipher`, and a head with `CRYPTO_ALG_ASYNC` set in `.cra_flags`. Different combinations of hardware and driver software version support different sets of algorithms, so searching for the driver name in `/proc/crypto` on the desired target system will ensure the correct report of what algorithms are supported.
- Authenticated Encryption with Associated Data (AEAD) algorithms
 

These algorithms are used in applications where the data to be encrypted overlaps, or partially overlaps, the data to be authenticated, as is the case with IPsec and TLS protocols. These algorithms are implemented in the driver such that the hardware makes a single pass over the input data, and both encryption and authentication data are written out simultaneously. The AEAD algorithms are mainly for use with IPsec ESP (however there is also support for TLS (1.x) record layer encryption (KTLS Support)). CAAM drivers currently supports offloading the following AEAD algorithms:

  - "stitched" AEAD: all combinations of { `NULL`, `CBC-AES`, `CBC-DES`, `CBC-3DES-EDE`, `RFC3686-CTR-AES` } x `HMAC-{MD-5, SHA-1, -224, -256, -384, -512}`
  - "true" AEAD: generic GCM-AES, GCM-AES used in IPsec: `RFC4543-GCM-AES` and `RFC4106-GCM-AES`
- Encryption algorithms
 

The CAAM driver currently supports offloading the following encryption algorithms.
- Authentication algorithms
 

The CAAM driver's `ahash` support includes keyed (`hmac`) and unkeyed hashing algorithms.
- Asymmetric (public key) algorithms
 

Currently, CAAM driver supports RSA-Encrypt and RSA-Decrypt together with `pkcs1pad` (`rsa-caam`, `sha256`) driver.
- Algorithms supported by CAAM drivers

```
root@imx8mqevk:~# cat /proc/crypto | grep caam driver : pkcs1pad(rsa-
caam,sha256) driver : rsa-caam driver : cmac-aes-caam driver : xcbc-aes-caam
driver : md5-caam driver : hmac-md5-caam driver : sha256-caam driver : hmac-
sha256-caam driver : sha224-caam driver : hmac-sha224-caam driver : sha1-
caam driver : hmac-sha1-caam driver : seqiv-authenc-hmac-sha256-rfc3686-ctr-
aes-caam driver : authenc-hmac-sha256-rfc3686-ctr-aes-caam driver : seqiv-
```

```

authenc-hmac-sha224-rfc3686-ctr-aes-caam driver : authenc-hmac-sha224-rfc3686-
ctr-aes-caam driver : seqiv-authenc-hmac-sha1-rfc3686-ctr-aes-caam driver :
authenc-hmac-sha1-rfc3686-ctr-aes-caam driver : seqiv-authenc-hmac-md5-
rfc3686-ctr-aes-caam driver : authenc-hmac-md5-rfc3686-ctr-aes-caam driver :
echainiv-authenc-hmac-sha256-cbc-des-caam driver : authenc-hmac-sha256-cbc-
des-caam driver : echainiv-authenc-hmac-sha224-cbc-des-caam driver : authenc-
hmac-sha224-cbc-des-caam driver : echainiv-authenc-hmac-sha1-cbc-des-caam
driver : authenc-hmac-sha1-cbc-des-caam driver : echainiv-authenc-hmac-md5-
cbc-des-caam driver : authenc-hmac-md5-cbc-des-caam driver : echainiv-authenc-
hmac-sha256-cbc-des3_edec-caam driver : authenc-hmac-sha256-cbc-des3_edec-caam
driver : echainiv-authenc-hmac-sha224-cbc-des3_edec-caam driver : authenc-hmac-
sha224-cbc-des3_edec-caam driver : echainiv-authenc-hmac-sha1-cbc-des3_edec-caam
driver : authenc-hmac-sha1-cbc-des3_edec-caam driver : echainiv-authenc-hmac-
md5-cbc-des3_edec-caam driver : authenc-hmac-md5-cbc-des3_edec-caam driver :
echainiv-authenc-hmac-sha256-cbc-aes-caam driver : authenc-hmac-sha256-cbc-
aes-caam driver : echainiv-authenc-hmac-sha224-cbc-aes-caam driver : authenc-
hmac-sha224-cbc-aes-caam driver : echainiv-authenc-hmac-sha1-cbc-aes-caam
driver : authenc-hmac-sha1-cbc-aes-caam driver : echainiv-authenc-hmac-md5-
cbc-aes-caam driver : authenc-hmac-md5-cbc-aes-caam driver : authenc-hmac-
sha256-ecb-cipher_null-caam driver : authenc-hmac-sha224-ecb-cipher_null-caam
driver : authenc-hmac-sha1-ecb-cipher_null-caam driver : authenc-hmac-md5-ecb-
cipher_null-caam driver : gcm-aes-caam driver : rfc4543-gcm-aes-caam driver :
rfc4106-gcm-aes-caam driver : ecb-arc4-caam driver : ecb-des3-caam driver :
tk-ecb-aes-caam driver : ecb-aes-caam driver : ecb-des-caam driver : rfc3686-
ctr-aes-caam driver : ctr-aes-caam driver : cbc-des-caam driver : cbc-3des-caam
driver : tk-cbc-aes-caam driver : cbc-aes-caam root@imx8mqevk:~#

```

### 10.3 CAAM Job Ring backend driver specifications

CAAM Job Ring backend driver (`caam_jr`) implements and uses the job ring interface (JRI) for submitting crypto API service requests from the frontend drivers (`caamalg`, `caamhash`, `caampkc`, `caamrng`, `caamkeyblob`) to CAAM engine.

CAAM drivers have a few options, most notably hardware job ring size and interrupt coalescing. They can be used to fine-tune performance for a particular use case.

The option Freescale CAAM Job Ring driver backend enables the Job Ring backend (`caam_jr`). The sub-option Job Ring Size allows the user to select the size of the hardware job rings. If requests arrive at the driver enqueue entry point in a bursty nature, the bursts' maximum length can be approximated. The user can set the greatest burst length to save performance and memory consumption.

The sub-option Job Ring interrupt coalescing allows the user to select the use of the hardware's interrupt coalescing feature. Note that the driver already performs IRQ coalescing in software, and zero-loss benchmarks have in fact produced better results with this option turned off. If selected, two additional options become effective:

- **Job Ring interrupt coalescing count threshold** (`CRYPTO_DEV_FSL_CAAM_INTC_THLD`) Device Drivers. Selects the value of the descriptor completion threshold, in the range 1-256. A selection of 1 effectively defeats the coalescing feature, and any selection equal or greater than the selected ring size will force timeouts for each interrupt.
- **Job Ring interrupt coalescing timer threshold** (`CRYPTO_DEV_FSL_CAAM_INTC_TIME_THLD`) Selects the value of the completion timeout threshold in multiples of 64 CAAM interface clocks, to which, if no new descriptor completions occur within this window (and at least one completed job is pending), then an interrupt will occur. This is selectable in the range 1-65535.

The options to register to Crypto API, `hwrng` API respectively, allow the frontend drivers to register their algorithm capabilities with the corresponding APIs. They should be deselected only when the purpose is to perform Crypto API requests in software (on the GPPs) instead of offloading them on CAAM engine.

`caamhash` frontend (hash algorithms) may be individually turned off, since the nature of the application may be such that it prefers software (core) crypto latency due to many small-sized requests.

`caampkc` frontend (public key / asymmetric algorithms) can be turned off too, if needed.

`caamrng` frontend (Random Number Generation) may be turned off in case there is an alternate source of entropy available to the kernel.

`caamkeyblob` frontend (algorithms supporting tagged key) can be turned off if tagged keys or blobs are not used.

### 10.3.1 Verifying driver operation and correctness

Other than noting the performance advantages due to the crypto offload, one can also ensure the hardware is doing the crypto by looking for driver messages in `dmesg`. The driver emits console messages at initialization time:

```
[ 1.830397] caam 30900000.crypto: device ID = 0x0a16040100000000 (Era 9)
[ 1.837113] caam 30900000.crypto: job rings = 2, qi = 0
[ 1.849949] caam algorithms registered in /proc/crypto
[ 1.855972] caam 30900000.crypto: caam pkc algorithms registered in /proc/
crypto
[ 1.865564] caam_jr 30901000.jr: registering rng-caam
[ 1.870766] Device caam-keygen registered
```

If the messages are not present in the logs, either the driver is not configured in the kernel, or no CAAM compatible device tree node is present in the device tree.

### 10.3.2 Incrementing IRQs in /proc/interrupts

Given a time period when crypto requests are being made, the CAAM hardware will fire completion notification interrupts on the corresponding Job Ring:

```
root@imx8qxpmeek:~# cat /proc/interrupts | grep jr
418:          1059             0             0             0          GICv3 485 Level
      31430000.jr2
419:           21             0             0             0          GICv3 486 Level
      31440000.jr3
root@imx8qxpmeek:~#
```

If the number of interrupts fired increment, then the hardware is being used to do the crypto. If the numbers do not increment, then check the algorithm being exercised is supported by the driver. If the algorithm is supported, there is a possibility that the driver is in polling mode (NAPI mechanism) and the hardware statistics in debugfs (inbound/outbound bytes encrypted/protected - see below) should be monitored.

### 10.3.3 Verifying the 'self test' fields say 'passed' in /proc/crypto

An entry such as the one below means the driver has successfully registered support for the algorithm with the kernel crypto API:

```
name          : cbc(des)
driver        : cbc-des-caam
module       : kernel
priority     : 3000
refcnt       : 1
selftest     : passed
internal     : no
```

```

type      : givcipher
async    : yes
blocksize : 8
min keysize : 8
max keysize : 8
ivsize   : 8
geniv    : <built-in>

```

Note that although a test vector may not exist for a particular algorithm supported by the driver, the kernel will emit messages saying which algorithms weren't tested, and mark them as 'passed' anyway:

```

[ 4.647985] alg: No test for authenc(hmac(sha224),ecb(cipher_null)) (authenc-
hmac-sha224-ecb-cipher_null-caam)
[ 4.661181] alg: No test for authenc(hmac(sha256),ecb(cipher_null)) (authenc-
hmac-sha256-ecb-cipher_null-caam)
[ 4.671345] alg: No test for authenc(hmac(sha384),ecb(cipher_null)) (authenc-
hmac-sha384-ecb-cipher_null-caam)
[ 4.681486] alg: No test for authenc(hmac(sha512),ecb(cipher_null)) (authenc-
hmac-sha512-ecb-cipher_null-caam)

```

## 10.4 OpenSSL offload

The Secure Socket Layer (SSL) protocol is the most widely deployed application protocol to protect data during transmission by encrypting the data using commonly used cipher algorithms such as AES, DES and 3DES. Apart from encryption, it also provides message authentication services using hash/digest algorithms such as SHA1 and MD5. SSL is widely used in application web servers (HTTP) and other applications such as SMTP POP3, IMAP, and Proxy servers, where protection of data in transit is essential for data integrity. There are various versions of SSL protocol such as TLSv1.0, TLSv1.1, TLSv1.2, TLSv1.3, and DTLS (Datagram TLS). This document describes NXP SSL acceleration solution on i.MX platforms using OpenSSL:

- OpenSSL software architecture
- Building OpenSSL with hardware offload support
- Examples of OpenSSL Offloading

### 10.4.1 OpenSSL software architecture

The SSL protocol is implemented as a library in OpenSSL - the most popular library distribution in Linux and BSD systems. The OpenSSL library has several sub-components such as:

- SSL protocol library
- SSL protocol library Crypto library (Symmetric and Asymmetric cipher support, digest support, etc.)
- Certificate Management

The following figure presents the general interconnect architecture for OpenSSL. Each relevant layer is represented with a clear separation between Linux User Space and Linux Kernel Space.



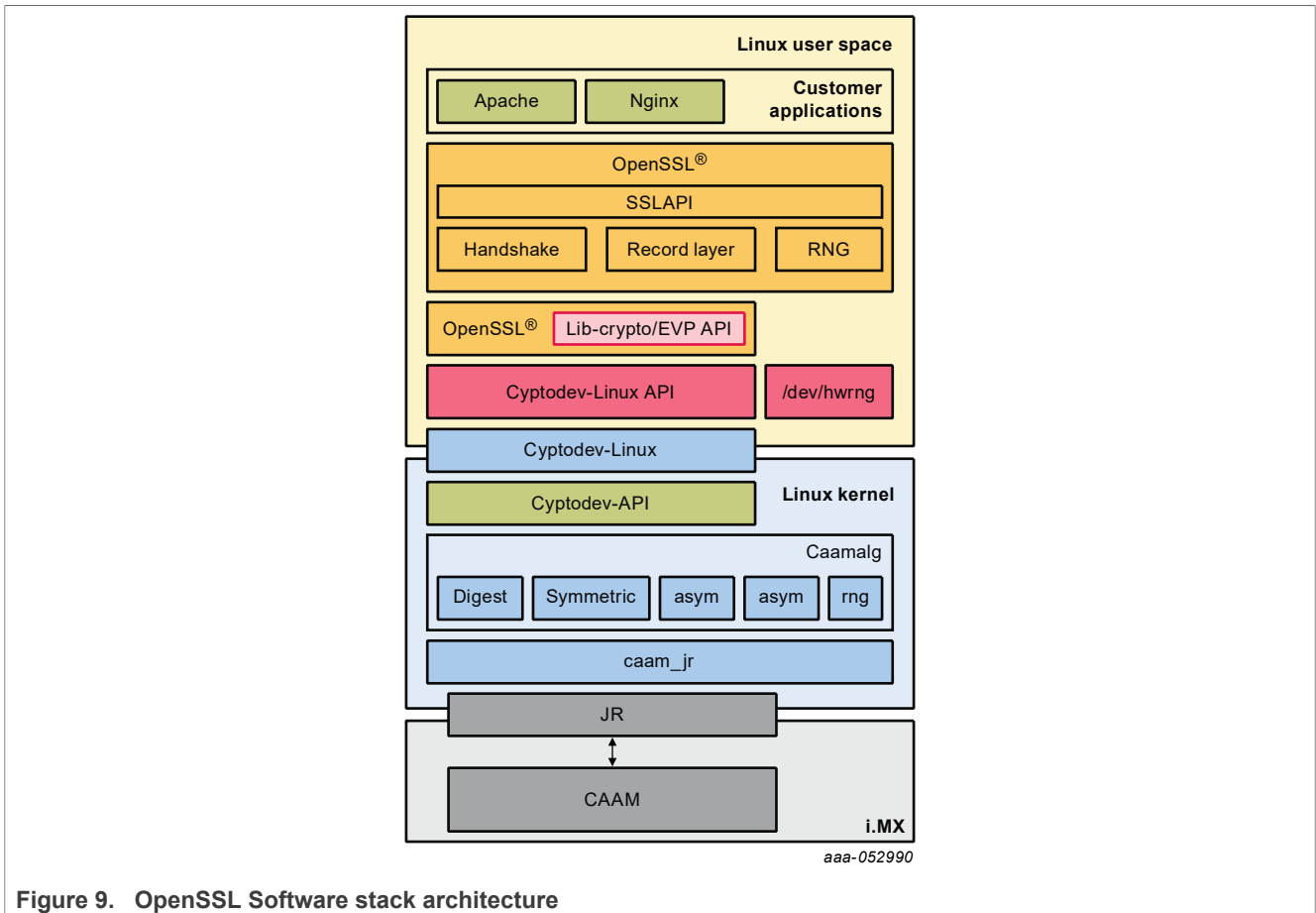

Figure 9. OpenSSL Software stack architecture

### 10.4.2 OpenSSL's ENGINE interface

OpenSSL Crypto library provides Symmetric and Asymmetric (PKI) cipher support that is used in a wide variety of applications such as OpenSSH, OpenVPN, PGP, IKE, and XML-SEC. The OpenSSL Crypto library provides software support for:

- Cipher algorithms
- Digest algorithms
- Random number generation
- Public Key Infrastructure

Apart from the software support, the OpenSSL can offload these functions to hardware accelerators through the ENGINE interface. The ENGINE interface provides callback hooks that integrate hardware accelerators with the crypto library. The callback hooks provide the glue logic to interface with the hardware accelerators. Generic offloading of cipher and digests algorithms through Linux kernel is possible with cryptodev engine.

### 10.4.3 NXP solution for OpenSSL hardware offloading

The following layers can be observed in NXP's solution for OpenSSL hardware offloading:

- OpenSSL (user space): implements the SSL protocol
- cryptodev-engine (user space): implements the OpenSSL ENGINE interface; talks to cryptodev-linux (/dev/crypto) through ioctls, offloading cryptographic operations in the kernel

- `cryptodev-linux` (kernel space): Linux module that translates `ioctl` requests from `cryptodev-engine` into calls to Linux Crypto API
- `AF_ALG` is a netlink-based in the kernel asynchronous interface that adds an `AF_ALG` address family introduced in 2.6.38.
- Linux Crypto API (kernel space): Linux kernel crypto abstraction layer
- CAAM driver (kernel space): Linux device driver for the CAAM crypto engine

The following are offloaded in hardware in current BSP:

- Symmetric Cipherring operations - AES (CBC, ECB), 3DES (CBC, ECB)
- Digest Operations - SHA (1, 256, 384, 512), MD5
- Public Key Operations - RSA Sign (1k, 2k, 4k) / RSA Verify (1k, 2k, 4k)

#### 10.4.4 Deploying OpenSSL into rootfs

Typically, the `imx-image-full` includes the OpenSSL and `cryptodev` modules, but for other Yocto targets, users need to update the `conf` file from the build directory. Update `conf/local.conf` by adding the following line:

```
CORE_IMAGE_EXTRA_INSTALL+="cryptodev-module openssl-bin"
```

Restart the build procedure:

```
bitbake imx-image-full
```

#### 10.4.5 Running OpenSSL benchmarking tests with cryptodev engine

Probe the `cryptodev-module`:

```
root@imx8qxpmeek:~# modprobe cryptodev
[17044.896494] cryptodev: driver 1.10 loaded.
root@imx8qxpmeek:~# openssl engine
(devcrypto) /dev/crypto engine
(dynamic) Dynamic engine loading support
root@imx8qxpmeek:~#
```

##### Note:

Starting from OpenSSL 1.1.1, the `cryptodev engine` is invoked by OpenSSL by default if the corresponding module has been inserted in the kernel. Thus to perform only SW benchmark test using OpenSSL, remove the `cryptodev module` by running `rmmmod cryptodev`.

##### 10.4.5.1 Running OpenSSL benchmarking tests for symmetric cipherring and digest

In the speed test file, a series of performance tests are made to check the performance of the symmetric and digest operations. The following is described in the OpenSSL test execution:

```
root@imx8qxpmeek:~# openssl speed -engine devcrypto -multi 8 -elapsed -evp aes-128-cbc
Forked child 1
engine "devcrypto" set.
Forked child 2
engine "devcrypto" set.
...
Got: +F:22:aes-128-cbc:378616.72:1611328.00:5084501.33:13994666.67:10731793.98:16219060.40 from 6
Got: +H:16:64:256:1024:8192:16384 from 7
Got: +F:22:aes-128-cbc:120773.33:9344.00:3088298.67:13588480.00:31642965.33:16471967.79 from 7
OpenSSL 1.1.1b 26 Feb 2019
built on: Thu Nov 14 13:22:07 2019 UTC
options:bn(64,64) rc4(char) des(int) aes(partial) idea(int) blowfish(ptr)
```

```

compiler: aarch64-poky-linux-gcc --sysroot=recipe-sysroot -O2 -pipe -g -feliminate-unused-debug-
types -fmacro-prefix-map=
-fdebug-prefix-map= -fdebug-prefix-map= -fdebug-prefix-map= -DOPENSSL_USE_NODELETE -DOPENSSL_PIC -
DOPENSSL_CPUID_OBJ -DOPENSSL_BN_ASM_MONT
-DSHA1_ASM -DSHA256_ASM -DSHA512_ASM -DKECCAK1600_ASM -DVPAES_ASM -DECP_NISTZ256_ASM -DPOLY1305_ASM
-DNDEBUG
evp                2242.05k      9681.05k      35017.46k      106866.86k      127787.74k      130077.23k
root@imx8qxpmeek:~#

```

Additional ciphers that could be benchmarked: aes-192-cbc, aes-256-cbc, aes-128-ecb, aes-192-ecb, aes-256-ecb, aes-128-ctr, aes-192-ctr, aes-256-ctr, des-cbc, des-cbc, des-ede3-cbc.

Additional digests that could be benchmarked: sha1, sha224, sha256, sha384, sha512, md5.

## 10.4.6 Running OpenSSL benchmarking tests with AF\_ALG engine

Execute the following commands:

```

Probe the af_alg:
root@imx8mmevk:~# rmmod cryptodev
root@imx8mmevk:~# modprobe af_alg
root@imx8mmevk:~# modprobe algif_hash
root@imx8mmevk:~# modprobe algif_skcipher
root@imx8mmevk:~# modprobe algif_rng
root@imx8mmevk:~# modprobe algif_aead

```

### 10.4.6.1 Running OpenSSL benchmarking tests for symmetric ciphering and digest

Execute the following command:

```

root@imx8mmevk:~# openssl speed -engine afalg -multi 8 -elapsed -evp aes-128-cbc
Forked child 0
Forked child 1
engine "afalg" set.
+DT:aes-128-cbc:3:16
engine "afalg" set.
engine "afalg" set.
engine "afalg" set.
...
Got: +H:16:64:256:1024:8192:16384 from 0
Got: +F:22:aes-128-cbc:333888.00:1359317.33:4248405.33:5720064.00:6160384.00:6176768.00 from 0
Got: +H:16:64:256:1024:8192:16384 from 1
Got: +F:22:aes-128-cbc:378336.00:1382826.67:5117269.33:5739178.67:6190421.33:6176768.00 from 1
...
OpenSSL 1.1.1k 25 Mar 2021
built on: Thu Mar 25 13:28:38 2021 UTC
options:bn(64,64) rc4(char) des(int) aes(partial) blowfish(ptr)
compiler: aarch64-poky-linux-gcc -mcpu=cortex-a53 -march=armv8-a+crc+crypto -fstack-protector-
strong -O2 -D_FORTIFY_SOURCE=2 -Wformat -Wformat-security -Werror=format-security --sysroot=recipe-
sysroot -O2 -pipe -g -feliminate-unused-debug-types -fmacro-prefix-map=
-fdebug-prefix-map= -fdebug-prefix-map= -fdebug-prefix-map=
map= -DOPENSSL_USE_NODELETE -DOPENSSL_PIC -DOPENSSL_CPUID_OBJ -DOPENSSL_BN_ASM_MONT -DSHA1_ASM -
DSHA256_ASM -DSHA512_ASM -DKECCAK1600_ASM -DVPAES_ASM -DECP_NISTZ256_ASM -DPOLY1305_ASM -DNDEBUG
evp                2682.45k      10842.73k      35957.50k      45915.48k      49722.71k      50135.04k

```

## 10.4.7 Running OpenSSL asymmetric tests with PKCS#11 based engine

Prerequisites:

1. For running the PKCS#11 OpenSSL Engine with our PKCS#11 Library, add the following into your global OpenSSL configuration file (often in `/etc/ssl/openssl.cnf`).

This line must be placed at the top, before any sections are defined:

```
openssl_conf = openssl_init
```

Make sure there are no other `openssl_conf = ...` lines in the file.

This should be added to the bottom of the file:

```
[openssl_init]
engines=engine_section
[engine_section]
pkcs11 = pkcs11_section
[pkcs11_section]
engine_id = pkcs11
dynamic_path = /usr/lib/engines-3/pkcs11.so
MODULE_PATH = /usr/lib/libckteec.so.0
init = 0
```

The `dynamic_path` value is the PKCS#11 engine plug-in, and the `MODULE_PATH` value is the NXP PKCS#11 library. The `engine_id` value is an arbitrary identifier for OpenSSL applications to select the engine by the identifier.

## 2. Make sure tee-supPLICANT is running.

```
root@imx8mpevk:~# ps -aux | grep tee
root        661    0.0  0.0  76424  1432 ?        Ssl  May27   0:00 /usr/bin/tee-supPLICANT
```

If it is not running, run the following command:

```
root@imx8mpevk:~# tee-supPLICANT &
```

### 10.4.7.1 Running p11tool to generate key (RSA or EC)

```
root@imx8mpevk:~# mkdir /etc/gnutls
root@imx8mpevk:~# echo load=`find /usr/lib -name libckteec.so.0` > /etc/gnutls/pkcs11.conf
root@imx8mpevk:~# p11tool --list-tokens --provider=/usr/lib/libckteec.so.0
root@imx8mpevk:~# p11tool --initialize "<token url>" --label="<token label>"
Enter Security Officer's PIN:
root@imx8mpevk:~# p11tool --list-tokens --provider=/usr/lib/libckteec.so.0
root@imx8mpevk:~# p11tool --initialize-pin "<token url>"
Setting user's PIN...
Enter User's new PIN:
Token <token label> with URL <token url> requires security officer PIN
Enter PIN:<Security Officer's PIN>
```

To generate an RSA key:

```
root@imx8mpevk:~# p11tool --login --generate-rsa --bits=2048 --label="RSA-key-2048" --outfile="RSA-key-2048.pub" "<token url>" --set-pin="<user pin>"
root@imx8mpevk:~# p11tool --login --list-privkeys "<token url>" --set-pin="<user pin>"
Object 0:
  URL: token url private
  Type: Private key (RSA-2048)
  Label: RSA-key-2048
  Flags: CKA_PRIVATE; CKA_NEVER_EXTRACTABLE; CKA_SENSITIVE;
  ID: bc:8e:f3:ca:95:d6:e7:ae:57:89:43:1f:67:a3:e5:d1:05:d8:5d:66
```

Or to generate an EC key:

```
root@imx8mpevk:~# p11tool --login --generate-ec --curve=secp256r1 --label="ec-
key-256" --outfile="ec-key-256.pub" "<token url>" --set-pin="<user pin>"
root@imx8mpevk:~# p11tool --login --list-privkeys "<token url>" --set-pin="<user
pin>"
Object 0:
  URL: token url private
  Type: Private key (EC/ECDSA-SECP256R1)
  Label: ec-key-256
  Flags: CKA_PRIVATE; CKA_NEVER_EXTRACTABLE; CKA_SENSITIVE;
  ID: 9b:54:b4:c5:88:3f:19:44:cb:b2:40:04:46:fa:a0:48:19:eb:0e:70
```

#### 10.4.7.2 Using OpenSSL from command line

To generate a certificate with its key in the PKCS #11 module, use the following commands. The first command creates a self-signed Certificate for "NXP Semiconductor". The signing is done using the key specified by the URL.

```
root@imx8mpevk:~# openssl req -engine pkcs11 -new -key "<token url private>" -
keyform engine -out req.pem -text -x509 -subj "/CN=NXP Semiconductor"
Engine "pkcs11" set.
Enter PKCS#11 token PIN for token label:<user pin>
```

The second command creates a self-signed certificate for the request. The private key used to sign the certificate is the same private key used to create the request.

```
root@imx8mpevk:~# openssl x509 -engine pkcs11 -signkey "<token url private>" -
keyform engine -in req.pem -out cert.pem
Engine "pkcs11" set.
Enter PKCS#11 token PIN for token label:<user pin>
root@imx8mpevk:~# ls
cert.pem req.pem
```

#### 10.4.7.3 Running OpenSSL test for RSA

```
root@imx8mpevk:~# echo "This is plain message 2021-01-18" > plain.text
root@imx8mpevk:~# openssl pkeyutl -engine pkcs11 -encrypt -in plain.text -out
encrypted.enc -inkey cert.pem -certin
root@imx8mpevk:~# openssl pkeyutl -engine pkcs11 -decrypt -in encrypted.enc -out
plain.dec -inkey "<token url private>" -keyform engine
Engine "pkcs11" set.
Enter PKCS#11 token PIN for token label:<user pin>
root@imx8mpevk:~# cat plain.text
This is plain message 2021-01-18
root@imx8mpevk:~# cat plain.dec
This is plain message 2021-01-18
```

#### 10.4.7.4 Running OpenSSL test for EC

```
root@imx8mpevk:~# echo "This is plain message 2021-01-18" > plain.text
root@imx8mpevk:~# openssl pkeyutl -engine pkcs11 -sign -in plain.text -out
cert_ecc.sign -inkey "<token url private>" -keyform engine
Engine "pkcs11" set.
Enter PKCS#11 token PIN for token label:<user pin>
```

```
root@imx8mpevk:~# openssl pkeyutl -verify -in plain.text -sigfile cert_ecc.sign
-inkey ecc_cert.pem -certin
Signature Verified Successfully
```

### 10.5 Disk encryption acceleration

Disk encryption is a technology that protects information by converting it into unreadable code that cannot be deciphered easily by unauthorized people. Disk encryption uses disk encryption software or hardware to encrypt every bit of data that goes on a disk or disk volume. It is used to prevent unauthorized access to data storage. On i.MX Applications Processors, the disk encryption scenarios could be implemented in various ways with different methods of key protection.

This section provides steps to run a transparent storage encryption at block level using DM-Crypt. The figure below presents the software stack that implements disk encryption.

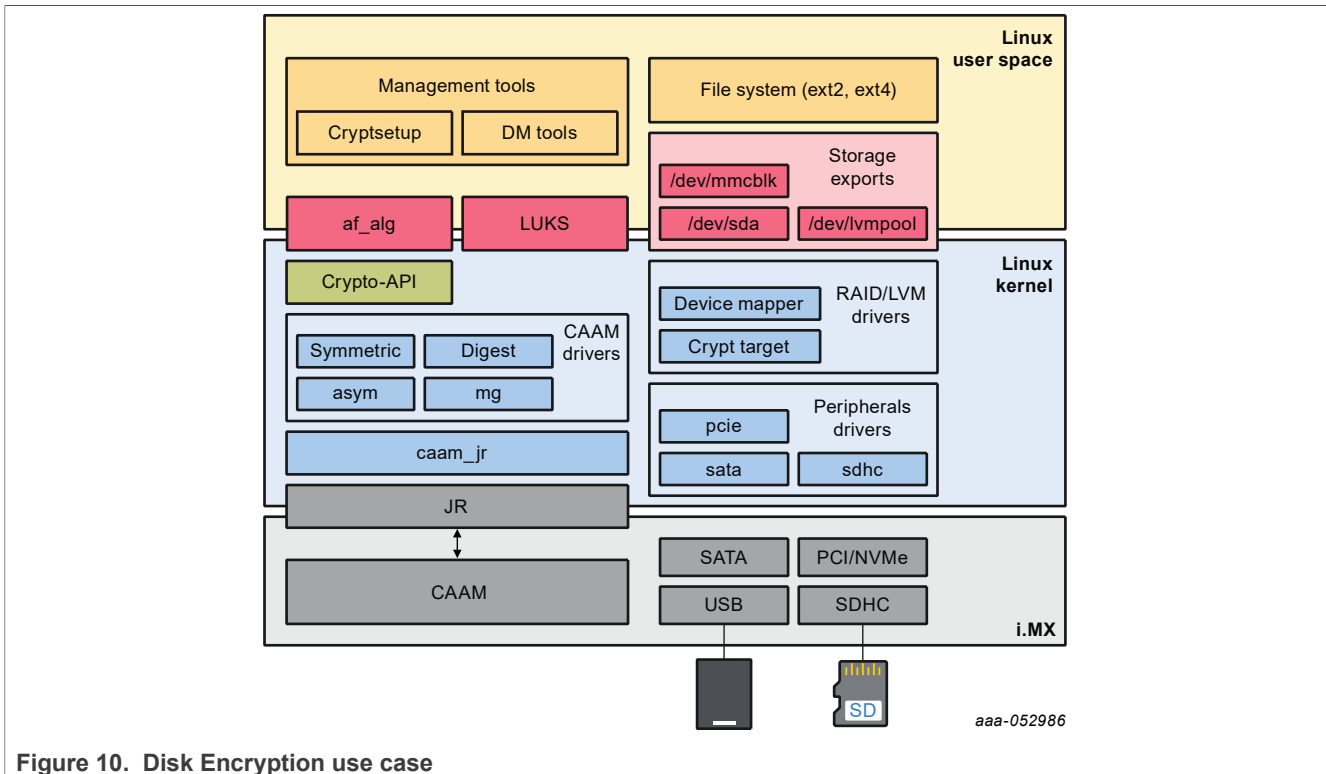

Figure 10. Disk Encryption use case

#### 10.5.1 Enabling disk encryption support in kernel

By default, the kernel configuration file enables the Device Mapper configuration and Crypt Target support as modules. Therefore, to enable disk encryption scenario, after the board is booted up, insert the following modules:

```
root@imx8mqevk:/# modprobe dm-mod
[ 266.982638] device-mapper: ioctl: 4.41.0-ioctl (2019-09-16) initialised: dm-
devel@redhat.com
root@imx8mqevk:/# modprobe dm-crypt
root@imx8mqevk:/# dmsetup targets
crypt                v1.19.0
striped              v1.6.0
linear               v1.4.0
```

error v1.5.0

If the disk encryption scenario is not enabled, some features in the kernel need to be enabled:

Kernel Configure Tree View Options	Description
<pre>&lt; Device Drivers ---&gt; [*] Multiple devices driver support (RAID and LVM) - --&gt; &lt;*&gt; Device mapper support [ ] Device mapper debugging support &lt; &gt; Unstriped target (NEW) &lt;*&gt; Crypt target support &lt;*&gt; Multipath target [*] DM uevents</pre>	<p>DM Crypt support enablement in Linux kernel</p> <p>CONFIG_BLK_DEV_DM=y</p>
<pre>&lt; Cryptographic API ---&gt; &lt;*&gt; User-space interface for hash algorithms &lt;*&gt; User-space interface for symmetric key cipher algorithms &lt;*&gt; User-space interface for AEAD cipher algorithms</pre>	<p>Enable user space crypto API's to allow simple cryptsetup benchmarks</p>
<pre>Cryptographic API ---&gt; [*] Hardware crypto devices ---&gt; &lt;*&gt; CAAM/SNVS Security Violation Handler (EXPERIMENTAL) &lt;*&gt; Freescale CAAM-Multicore platform driver backend [ ] Enable debug output in CAAM driver &lt;*&gt; Freescale CAAM Job Ring driver backend ---&gt; [*] Register tagged key cryptography implementations with Crypto API</pre>	<p>Selecting this will register algorithms supporting tagged key, generate black keys and encapsulate them into black blobs.</p>

### 10.5.2 User space tools for disk encryption

All the required user space tools needed for DM-Crypt are already installed on the board when using Linux i.MX BSP.

If the required user space tools are not installed in the build, add them by editing the `conf/local.conf` file and appending:

```
CORE_IMAGE_EXTRA_INSTALL+="coreutils keyutils lvm2 e2fsprogs-mke2fs util-linux"
```

- `keyutils`: provides `keyctl`, which is required to manage Linux Key retention service.
- `lvm2`: provides `dmsetup` utility and libraries to manage device-mapper.
- `e2fsprogs-mke2fs`: contains necessary tools to create filesystems.
- `util-linux`: provides `blockdev` utility needed to read number of sectors from a volume.

### 10.5.3 DM-Crypt using CAAM backed keys

In Linux Unified Key Setup (LUKS) mode, to generate the disk encryption key (master key), the user supplies a passphrase, which is combined with a salt, and then a hash function is applied for a supplied number of rounds. When the user wants to mount an encrypted volume, the passphrase should be supplied. An alternative

could be providing a key file stored in an external drive containing necessary decryption information. Those approaches are not convenient with embedded devices usage.

The aim of using DM-Crypt with CAAM's secure key is to suppress the mechanism of encrypting the master volume key with a key derived from a user-supplied passphrase.

DM-Crypt can be leveraged with:

- Trusted keys backed by CAAM
- CAAM's tagged key

Linux OS provides an in-kernel key management and retention facility called Keyrings. Keyring also enables interfaces to allow accessing keys and performing operations such as add, update, and delete from user-space.

The kernel provides several basic types of keys including encrypted, trusted, user, and logon.

The CAAM driver has associated a user-space application used to generate:

- A plain key and encapsulate it into a Red blob
- A tagged key and encapsulate it into a black blob

### 10.5.3.1 DM-Crypt with Trusted keys backed by CAAM

DM-Crypt fetches the trusted key which was generated through CAAM, from the kernel keyring, to take advantage of CAAM state.

The key de-capsulated from Red-Blob is different for different CAAM states:

- If System is booted in secure boot with Chain-of-trust established, CAAM state is secure state.
- If system is booted in non-secure (or compromised) state, CAAM state is non-secure state.

**Note:**

*Data that was written in secure state using the trusted key, is not read back from non-trusted or compromised system.*

#### 10.5.3.1.1 Usage

The following steps shows how to perform a full disk encryption on i.MX devices using the DM-Crypt with Trusted keys backed by CAAM method.

1. Insert the kernel module.

```
$>: modprobe trusted
```

2. Generate the trusted key:

```
$>: KEYNAME=dm_trust
$>: KEY="$ (keyctl add trusted $KEYNAME 'new 32' @s) "
$>: keyctl pipe $KEY >~/ $KEYNAME.blob
$>: keyctl list @s
```

Output:

```
$>: keyctl list @s
2 keys in keyring:
 48178143: ----s-rv      0      0 user: invocation_id
143779047: --alswrv      0      0 trusted: dm_trust
```

3. Create a secure volume. It could be a physical partition. In this example, make use of an image file and mount it later.

```
$>: DEV=/dev/loop0
```



```
$>: BLOCKS=20
$>: fallocate -l $((BLOCKS*512)) ~/loop0.img
$>: losetup -P $DEV ~/loop0.img
```

4. Create the mapping table "TABLE". Where:

- Algo is set in Kernel Crypto API format to use the plain key. Algo/cipher is set to `cbc(aes)-plain`.
- Key is set as the trusted key of length 32 and the name is exported as `$KEYNAME`.

```
$>: DEV=/dev/loop0
$>: ALGO=capi:cbc(aes)-plain
$>: KEYNAME=dm_trust
$>: BLOCKS=20
$>: TARGET=crypt
$>: TABLE="0 $BLOCKS $TARGET $ALGO :32:trusted:$KEYNAME 0 $DEV 0 1
allow_discards"
```

5. Use `dmsetup` to create a new device-mapper device named `encrypted` for example, and specify the mapping table "TABLE" created above, as argument.

```
$>: echo $TABLE | dmsetup create encrypted
```

6. Load the device-mapper device named `encrypted` created in the previous step.

```
$>: echo $TABLE | dmsetup load encrypted
```

7. Create a secure volume.

```
$>: dd if=/dev/zero of=/dev/mapper/encrypted || true
```

8. Write to the volume.

```
$>: echo "It works. Congratulations" 1<> /dev/mapper/encrypted
```

9. Unmount the device.

```
$>: umount /mnt/encrypted/
```

10. Deactivate the device mapper device.

```
$>: dmsetup remove encrypted
```

Restart the board:

```
$>: reboot
```

11. In the next boot, insert the kernel module.

```
$>: modprobe trusted
Step 11: Load the trusted key:
$>: KEYNAME=dm_trust
$>: keyctl add trusted $KEYNAME "load $(cat ~/$KEYNAME.blob)" @s
$>: keyctl list @s
```

Output:

```
$>: keyctl list @s
2 keys in keyring:
 48178143: ----s-rv      0      0 user: invocation_id
143779047: --alswrv      0      0 trusted: dm_trust
```

12. Create the mapping table "TABLE". Where:

- Algo is set in Kernel Crypto API format to use the plain key. Algo/cipher is set to `cbc(aes)-plain`.
- Key is set as the trusted key of length 32 and name is exported as `$KEYNAME`.

```
$>: DEV=/dev/loop0
```

```
$>: ALGO=capi:cbc(aes) -plain
$>: KEYNAME=dm_trust
$>: BLOCKS=20
$>: TARGET=crypt
$>: TABLE="0 $BLOCKS $TARGET $ALGO :32:trusted:$KEYNAME 0 $DEV 0 1
allow_discards"
```

### 13. Mount the encrypted device.

```
$>: losetup -P $DEV ~/loop0.img
```

### 14. Specify the mapping table "TABLE" to encrypt the volume using dmsetup.

```
$>: echo $TABLE | dmsetup create encrypted
$>: echo $TABLE | dmsetup load encrypted
```

### 15. Read from the device to verify if the content is same as it was written in the previous boot.

```
$>: hexdump -C /dev/mapper/encrypted
```

#### 10.5.3.2 DM-Crypt with CAAM's tagged key

DM-Crypt can also take advantages of tagged key to protect storage volumes from offline decryption. In addition, the volume could only be opened by the devices that have the same OTPMK burned in the fuses. For more details, see the Security Reference Manual for specific SoC.

The tagged key feature is based on CAAM's black key mechanism. Black key protects user keys against bus snooping while the keys are being written to or read from memory external to the SoC. CAAM supports two different black key encapsulation schemes, which are AES-ECB and AES-CCM.

Regarding AES-ECB encryption, the data is a multiple of 16 bytes long and is intended for quick decryption.

The AES-CCM mode is not as fast as AES-ECB mode, but includes a "MAC tag" (integrity check value) that ensures the integrity of the encapsulated key. A CCM-encrypted black key is always at least 12 bytes longer than the encapsulated key (nonce value + MAC tag).

Black keys are session keys; therefore, they are not power-cycles safe. CAAM's blob mechanism provides a method for protecting user-defined data across system power cycles. It provides both confidentiality and integrity protection. The data to be protected is encrypted so that it can be safely placed into non-volatile storage before the SoC is powered down.

The following diagram illustrates the changes that have been added to support full disk encryption using tagged key. The CAAM driver registers new Cryptographic transformations in the kernel to use ECB and CBC blacken keys, tk(ecb(aes)) and tk(cbc(aes)). The tk prefix refers to Tagged Key.

A Tagged Key is a black key that contains metadata indicating what it is and how to handle it.

```
caam-keygen application. Usability should be updated as below:-
$ caam-keygen
CAAM keygen usage: caam-keygen [options]
Options:
create <key_name> <key_enc> <key_mode> <key_val>
<key_name> the name of the file that will contain the black key.
A file with the same name, but with .bb extension, will contain the black blob.
<key_enc> can be ecb or ccm
<key_mode> can be -s or -t.
  -s generate a black key from random with the size given in the next argument
  -t generate a black key from a plaintext given in the next argument
<key_val> the size or the plaintext based on the previous argument (<key_mode>)
<text_type> can be -h or -p (default argument is -p)
```

```

-h generate a black key from the hex text that is provided in previous
argument
-p generate a black key from the plain text that is provided in previous
argument
import <blob_name> <key_name>
<blob_name> the absolute path of the file that contains the blob
<key_name> the name of the file that will contain the black key.
derive [-pass <pass_phrase>] [-md <digest>] [-S <salt>] <derived_key_name>
<pass_phrase> password value
<digest> Supported digest:-
    sha1
    sha224
    sha256
    sha384
    sha512
Note:- Default algorithm is sha-256.
    <salt> [Optional] The actual salt to use.
    8 bytes salt value needs to be provided.
    If salt value > 8 bytes, trim to 8 bytes.
    If salt_value < 8 bytes, zero padding is added.
    If no salt is provided, -nosalt option will be used.
    <derived_key_name> Black key obtained after using PBKDF2
    derivation function.
    
```

By default, the keys and blobs are created in KEYBLOB\_LOCATION, which is /data/caam/.

Later, CAAM Tagged Key is added into Linux Key Retention service and managed by user-space application such as keyctl. Black blobs can be stored on any non-volatile storage.

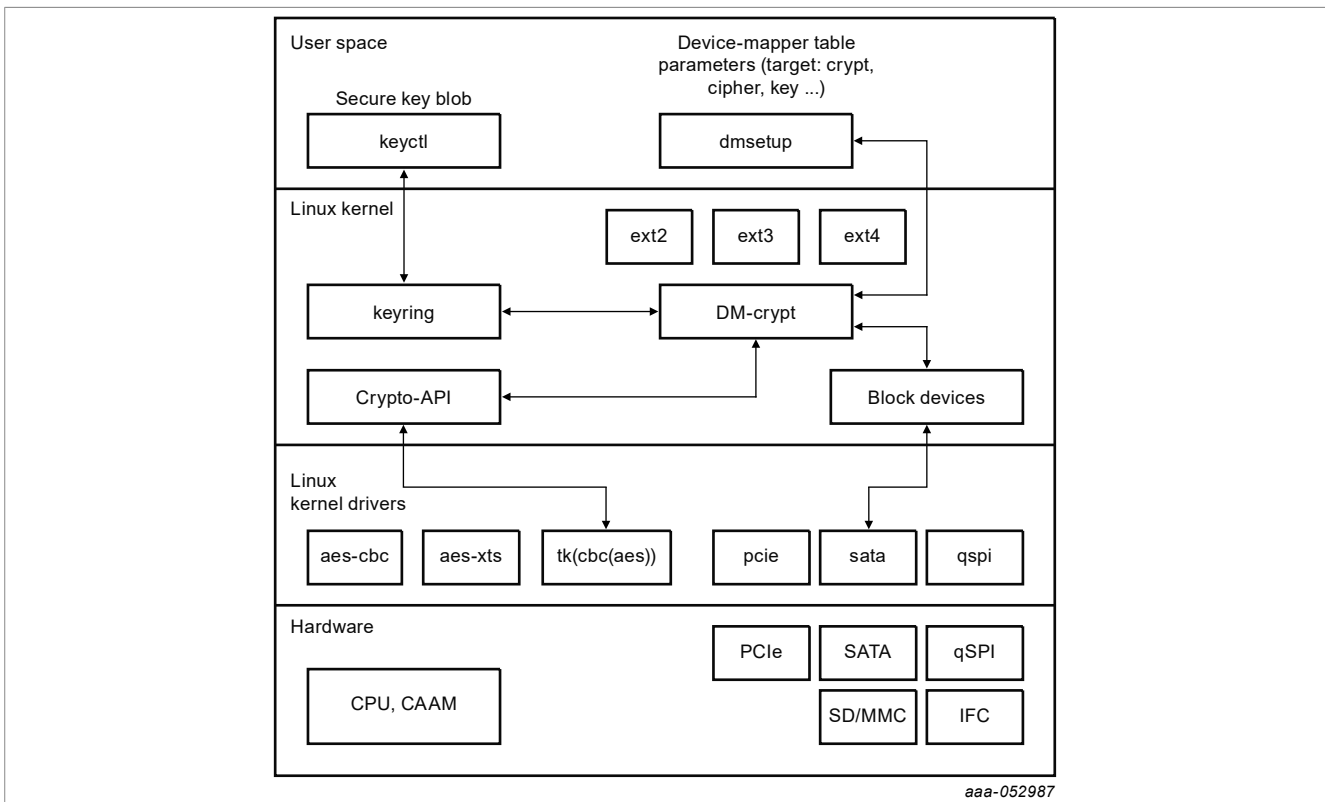

Figure 11. DM-Crypt using CAAM Tagged key - overall architecture

Dmsetup (part of the `libdevmapper` package) is a powerful tool for performing very low-level configuration and is used to manage encrypted volumes.

### 10.5.4 Usage

The following are the steps to perform a full disk encryption on i.MX devices using the DM-Crypt with CAAM's tagged key method.

1. After booting the device, make sure that cryptographic transformations using Tagged Key are registered.

```
root@imx8mqevk:~# grep -Bl -A2 tk- /proc/crypto | grep -v kernel
name      : tk(ecb(aes))
driver    : tk-ecb-aes-caam
priority  : 3000
--
name      : tk(cbc(aes))
driver    : tk-cbc-aes-caam
priority  : 3000
root@imx8mqevk:~#
```

And `caam-keygen` application is available:

```
root@imx8mqevk:~# cd /; find -name "caam-keygen"
./usr/bin/caam-keygen
./dev/caam-keygen
./sys/class/misc/caam-keygen
./sys/devices/virtual/misc/caam-keygen
```

For now, we only support AES algorithms. Therefore, the size of the key accepted for encryption/decryption is 16, 24, and 32 bytes.

2. Make sure DM-Crypt is enabled.

```
root@imx8mqevk:~# dmsetup targets
crypt          v1.19.0
striped       v1.6.0
linear        v1.4.0
error         v1.5.0
```

If any of the above is missing, check Kernel configurations or see section [Enable disk encryption support in kernel](#).

3. Then, provide the device with its key, the black key, which could be created either from a defined plain key or randomly.

Here is an example for black key encrypted with ECB, from a given plaintext of size 16 bytes:

```
root@imx8mqevk:~# ./caam-keygen create fromTextkey ecb -t 0123456789abcdef
```

The result is a Tagged Key and a Blob files written to filesystem (the default location is `/data/caam`). The used key encryption scheme is ECB.

```
root@imx8mqevk:~# ls -la /data/caam/
total 16
drwxr-xr-x 2 root root 4096 Aug 25 15:38 .
drwxr-xr-x 3 root root 4096 Aug 25 15:38 ..
-rw-r--r-- 1 root root   36 Aug 25 15:38 fromTextkey
-rw-r--r-- 1 root root   96 Aug 25 15:38 fromTextkey.bb
```

Next, add the key in key retention service, using `keyctl`:

```
root@imx8mqevk:~# cat /data/caam/fromTextkey | keyctl padd logon logkey: @s
876928653
```

4. Create a secure volume. It could be a physical partition. In this example, make use of an image file and mount it later.

```
root@imx8mqevk:~# dd if=/dev/zero of=encrypted.img bs=1M count=32
32+0 records in
32+0 records out
33554432 bytes (34 MB, 32 MiB) copied, 3.20227 s, 10.5 MB/s
root@imx8mqevk:~#
root@imx8mqevk:~# losetup /dev/loop0 encrypted.img
root@imx8mqevk:~#
```

5. Use `dmsetup` to create a new device-mapper device named `encrypted` for example, and specify the mapping table. The table can be provided on `stdin` or as argument.

```
root@imx8mqevk:~# dmsetup -v create encrypted --table "0 $(blockdev --getsz /dev/loop0) crypt
capi:tk(cbc(aes))-plain :36:logon:logkey: 0 /dev/loop0 0 1 sector_size:512"
Name:          encrypted
State:         ACTIVE
Read Ahead:   256
Tables present: LIVE
Open count:   0
Event number: 0
Major, minor: 253, 0
Number of targets: 1
```

The following is a breakdown of the mapping table:

- `start` means encrypting begins with sector 0.
- `size` is the size of the volume in sectors.
- `blockdev` gets the number of sectors of the device.
- `target` is `crypt`.
- `cipher` is set in Kernel Crypto API format to use Tagged Key. `cipher` set to `capi:tk(cbc(aes))-plain` and key set to `:36:logon:logkey:` leads to use of the logon key with CAAM Tagged Key transformation.
- `IV` is the Initialization Vector defined to plain, initial vector, which is the 32-bit little-endian version of the sector number, padded with zeros if necessary.
- `key type` is the Keyring key service type, set to Logon Key. 36 is the key size in bytes.
- `key name` is the key description to identify the key to load.
- `IV offset` is the value to add to sector number to compute the IV value.
- `device` is the path to device to be used as backend; it contains the encrypted data.
- `offset` represents encrypted data begins at sector 0 of the device.
- `optional parameters` represent the number of optional parameters.
- `sector_size` specifies the encryption sector size.

For more detailed options and descriptions, refer to <https://gitlab.com/cryptsetup/cryptsetup/-/wikis/DMCrypt>.

The created device appears in `/dev/mapper`:

```
root@imx8mqevk:~# dmsetup table --showkey encrypted
0 65536 crypt capi:tk(cbc(aes))-plain :36:logon:logkey: 0 7:0 0
```

6. Create a file system on the device.

```
root@imx8mqevk:~# mkfs.ext4 /dev/mapper/encrypted
mke2fs 1.45.3 (14-Jul-2019)
Creating filesystem with 32768 1k blocks and 8192 inodes
Filesystem UUID: 3ba01ad8-ba03-4389-a955-5136b3173c35
Superblock backups stored on blocks:
    8193, 24577
Allocating group tables: done
Writing inode tables: done
Creating journal (4096 blocks): done
```

```
Writing superblocks and filesystem accounting information: done
```

#### 7. Set up a mount point.

```
root@imx8mqevk:~# mkdir /mnt/encrypted
```

#### 8. Mount the mapped device.

```
root@imx8mqevk:~# mount -t ext4 /dev/mapper/encrypted /mnt/encrypted/
[ 9409.936183] EXT4-fs (dm-0): mounted filesystem with ordered data mode.
  Opts: (null)
[ 9409.943892] ext4 filesystem being mounted at /mnt/encrypted supports
  timestamps until 2038 (0x7fffffff)
```

#### 9. Write to device.

```
root@imx8mqevk:~# echo "This is an encrypt with black key (ECB from text 16 bytes key size) test
of full disk encryption on i.MX" > /mnt/encrypted/readme.txt
```

#### 10. Unmount the device.

```
root@imx8mqevk:~# umount /mnt/encrypted/
```

#### 11. Deactivate the device mapper device.

```
root@imx8mqevk:~# dmsetup remove encrypted
```

#### 12. Restart the board.

```
root@imx8mqevk:~# reboot
...
root@imx8mqevk:~#
```

#### 13. Import the key from blob and add it to key retention service.

```
root@imx8mqevk:~# ./caam-keygen import /data/caam/fromTextkey.bb importKey
root@imx8mqevk:~# cat /data/caam/importKey | keyctl padd logon logkey2: @s
605536287
root@imx8mqevk:~# ls -la /data/caam/
total 20
drwxr-xr-x 2 root root 4096 Aug 25 15:47 .
drwxr-xr-x 3 root root 4096 Aug 25 15:38 ..
-rw-r--r-- 1 root root  36 Aug 25 15:38 fromTextkey
-rw-r--r-- 1 root root  96 Aug 25 15:38 fromTextkey.bb
-rw-r--r-- 1 root root  36 Aug 25 15:47 importKey
root@imx8mqevk:~#
```

#### 14. Mount the encrypted device.

```
root@imx8mqevk:~# losetup /dev/loop0 encrypted.img
root@imx8mqevk:~#
```

#### 15. Specify the mapping table to encrypt the volume using dmsetup.

```
root@imx8mqevk:~# dmsetup -v create encrypted --table "0 $(blockdev --getsz /dev/loop0) crypt
  capi:tk(cbc(aes))-plain :36:logon:logkey2: 0 /dev/loop0 0 1 sector_size:512"
Name:          encrypted
State:         ACTIVE
Read Ahead:   256
Tables present: LIVE
Open count:   0
Event number: 0
Major, minor: 253, 0
Number of targets: 1
```

#### 16. Mount.

```
root@imx8mqevk:~# mount /dev/mapper/encrypted /mnt/encrypted/
```

```
[ 191.961828] EXT4-fs (dm-0): mounted filesystem with ordered data mode.
  Opts: (null)
[ 191.969533] ext4 filesystem being mounted at /mnt/encrypted supports
  timestamps until 2038 (0x7fffffff)
root@imx8mqevk:~
```

#### 17. Read from the device.

```
root@imx8mqevk:~# cat /mnt/encrypted/readme.txt
This is an encrypt with black key (ECB from text 16 bytes key size) test of
full disk encryption on i.MX.
root@imx8mqevk:~#
```

#### 18. Unmount the device and deactivate the device mapper device.

```
root@imx8mqevk:~# umount /mnt/encrypted/; dmsetup remove encrypted
```

## 10.6 crypto\_af\_alg application support

### 10.6.1 Prerequisites

The caam-keygen application is needed to import the black key from the black blob. Make sure that the caam-keygen application is already present at `/usr/bin`.

### 10.6.2 Building the kernel

#### 10.6.2.1 Kernel configuration

- CONFIG\_CRYPT\_USER\_API
- CONFIG\_CRYPT\_USER\_API\_HASH
- CONFIG\_CRYPT\_USER\_API\_SKCIPHER
- CONFIG\_CRYPT\_USER\_API\_RNG
- CONFIG\_CRYPT\_USER\_API\_AEAD

Get a bootable image that includes the black key support and AF\_ALG socket interface for the Linux kernel. Or build the kernel from here: <https://github.com/nxp-imx/linux-imx/>.

#### 10.6.2.2 Building a toolchain

Build a toolchain to cross compile the sources of the caam-crypt application. For details, see the *i.MX Yocto Project User's Guide* (IMXLXOCTOUG).

```
$ wget https://developer.arm.com/-/media/Files/downloads/gnu-a/8.2-2019.01/gcc-arm-8.2-2019.01-x86_64-aarch64-elf.tar.xz
$ tar xf gcc-arm-8.2-2019.01-x86_64-aarch64-elf.tar.xz
```

#### 10.6.2.3 Cross compiling the user space sources

Set up the environment for cross compilation using the toolchain previously prepared.

1. In the toolchain folder, set up the environment.

```
$ export CROSS_COMPILE=<path to toolchain>/bin/aarch64-linux-gnu-
$ export CC=${CROSS_COMPILE}gcc
```

```
$ export LD=${CROSS_COMPILE}ld
```

2. Build the caam-crypt user space application. Go to the source folder and run:

```
$ make clean
$ make
```

### 10.6.3 Usage

After the device successfully boots with the previously generated image, caam-crypt can be used to decrypt an encrypted data stored in a file.

```
$ ./caam-crypt
Application usage: caam-crypt [options]
Options:
  <crypto_op> <algo> [-k <blob_name>] [-in <input_file>] [-out <output_file>] [-iv <IV value>]
  <crypto_op> can be enc or dec
    enc for encryption.
    dec for decryption.
  <algo> can be AES-256-CBC
  <blob_name> the absolute path of the file that contains the black blob
  <input_file> the absolute path of the file that contains input data
    In case of encryption, input file will contain plain data.
    In case of decryption, input file will contain encrypted data.
  <output_file> the absolute path of the file that contains output data
  <IV value> 16 bytes IV value
```

### 10.6.4 Use case example

- For encryption:

```
$ caam-crypt enc AES-256-CBC -k myblob -in <plain_text_file> -out
  <encrypted_file> -iv <16-byte IV value>
```

- For decryption:

```
$ caam-crypt dec AES-256-CBC -k myblob -in <encrypted_file> -out
  <decrypted_file> -iv <16-byte IV value>
```

where:

- **myblob**: Generated black key blob. The caam-keygen application imports a black key from black blob. This black key is used by CAAM for encryption/decryption.
- **AES-256-CBC**: Currently, the only supported symmetric algorithm used for encryption/decryption operation. **Note: Make sure that the algorithm used for encryption/decryption should be same.**
- **encrypted\_file**: Encrypted data stored in a file.
- **plain\_text\_file**: Plain text stored in a file (Padding is added for making data as multiples of block size).
- **decrypted\_file**: Decrypted data stored in a file.
- **iv**: 16 bytes IV value.

**Note:** Customer should increase `net.core.optmem_max` using the command below:

```
# sysctl -w net.core.optmem_max=1048576
```

The default value is set to **20480**. Increasing to **1048576** (1 MB) seems to fix the issue of decryption of file size greater than 1 MB.



## 10.7 Kernel TLS offload

Linux kernel provides TLS connection offload infrastructure. Once a TCP connection is in ESTABLISHED state, user space can enable the TLS Upper Layer Protocol (ULP) and install the cryptographic connection state. For details regarding the user-facing interface, refer to the TLS documentation in [Kernel TLS](#).

### 10.7.1 Prerequisites

Check OpenSSL version using the following command. It must be 3.0.0 or higher.

```
openssl version
```

### 10.7.2 Running Kernel TLS test

On server generate RSA 2048 key, certificate and run `openssl s_server`:

```
root@imx8mmevk:~# openssl req -new -newkey rsa:2048 -nodes -keyout rsa.key -out
rsa.csr
root@imx8mmevk:~# openssl x509 -req -sha256 -days 365 -in rsa.csr -signkey
rsa.key -out server.pem
root@imx8mmevk:~# openssl s_server -key rsa.key -cert server.pem -accept 443 -
ssl_config ktls
Using default temp DH parameters
ACCEPT
```

Run `openssl s_client` from another terminal:

```
root@imx8mmevk:~# openssl s_client -quiet -connect <server ip>:443 -tls1_2 -
ssl_config ktls -cipher 'ECDHE-RSA-AES256-GCM-SHA384'
Connecting to <server ip>
Can't use SSL_get_servername
...
Using Kernel TLS for sending
Using Kernel TLS for receiving
<write some message and enter>
```

Remove `-quiet` to see full client logs. With TLSv1.2, the Kernel TLS supports these ciphers:

- AES128-GCM-SHA256
- AES256-GCM-SHA384
- ECDHE-RSA-AES128-GCM-SHA256
- ECDHE-RSA-AES256-GCM-SHA384

## 10.8 IMA/EVM on i.MX SoCs

**Integrity Measurement Architecture (IMA):** is the Linux integrity subsystem used to detect if files have been accidentally or maliciously altered. It appraises a file's measurement against a "good" value stored as an extended attribute (`security.ima`) and enforces local file integrity checks. The extended attribute (`security.ima`) of a file is the hash value (SHA-1, SHA-256, or SHA-512) of its content. IMA maintains a list of hash values over all executables and other sensitive system files loaded at runtime into the system.

**Extended Verification Module (EVM):** protects a file's extended attributes against integrity attacks. The extended security attribute (`security.evm`) stores the HMAC value over other extended attributes associated with the file such as `security.selinux`, `security.SMACK64`, and `security.ima`.

EVM depends on the kernel key retention system and requires an encrypted key named `evm-key` for the HMAC operation. The key is loaded onto the root user keyring using `keyctl` utility. EVM is enabled by setting an enable flag in `securityfs/evm` file.

In normal secure boot process, contents of root file system mounted over persistent storage device are not validated by any mechanism and hence cannot be trusted. Any malicious changes in non-trusted rootfs contents are undetected. IMA EVM is the Linux standard mechanism to verify the integrity of the rootfs. Integrity checks over file attributes and its contents are performed by Linux IMA EVM module before its execution. IMA EVM depends on encrypted key loaded on user's keyring. Loading keys to root user keyring and enabling EVM is typically done using `initramfs` image. The `initramfs` image is validated using secure boot process and becomes the part of chain of trust. `initramfs` switches control to main rootfs mounted over storage device, after EVM is successfully enabled on the system.

### 10.8.1 EVM Key on user keyrings

The EVM security attribute depends on an encrypted key (named `evm-key`) loaded on the user keyring. The encrypted key is derived by the kernel using the master key. The master key can be of the following types:

- User-Key
- Secure-Key
- Trusted-Key

Secure and trusted keys are derived using a hardware security engine for greater security while the security of user-key depends on the user-defined mechanisms irrespective of the hardware. The secure-key is derived using the Layerscape's SEC (aka CAAM). The trusted-key can be used on the platforms supporting TPM.

The encrypted key acts as an HMAC key, which is subsequently used to calculate the HMAC value (`security.evm`) over other security attributes. This key is stored internally by the kernel and user can only see its blob.

### 10.8.2 Modes of operation in IMA EVM

IMA/EVM is enabled in two modes:

- Fix mode
- Enforce mode

To enable a system with IMA EVM, both modes must be implemented in a sequence as described below:

1. The system needs to be booted in fix mode with `ima_appraise=fix` and `evm=fix` bootargs. After loading the keys on the root keyring, the entire file system is labelled with security attributes. In fix mode, any file with `INTEGRITY_UNKNOWN` is labelled with proper attribute values. This mode must be executed only once while preparing system for field deployment.
2. After the fix mode execution is completed successfully, system needs to be booted IMA EVM in enforce mode. Enforce mode is enabled by setting `ima_appraise=enforce` bootargs. In enforce mode, the files are measured against their "good" values. In case there is a mismatch between calculated security attribute value and stored value, access to that file is denied. While in field the system boot is done in enforce mode only.

### 10.8.3 Build Steps

Follow instructions mentioned in <https://github.com/nxp-imx/meta-imx-integrity> for building `initramfs`.

1. After building `integrity-image-minimal-<board-name>-<build_no>.rootfs.tar.zst`, extract `tar.zst`.

- Convert the extracted directory into CPIO file using the following command:

```
find . | cpio -H newc -o > ../<rootfs_name>.cpio
```

- Gzip the built rootfs above using the following command:

```
gzip ../<rootfs_name>.cpio
```

- Convert gzipped rootfs into Ramdisk file using the following command:

```
mkimage -A arm -O linux -T ramdisk -d <gzipped_rootfs> <Ramdisk_name>
```

- Flash the kernel image, dtb file, and Ramdisk file on the i.MX board.

- For fix mode, add the following bootargs to the current bootargs:

```
rootwait rw lsm=integrity rootflags=i_version ima_appraise=fix  
ima_policy=appraise_tcb evm=fix initrd=<Ramdisk path>
```

- For enforce mode, add the following bootargs to the current bootargs:

```
rootwait rw lsm=integrity rootflags=i_version ima_appraise_tcb  
ima_appraise=enforce initrd=<Ramdisk path>"
```

#### 10.8.4 Steps to verify IMA EVM feature

Perform the following checks to ensure that IMA EVM is successfully enabled in enforce mode.

- Trusted keys and encrypted keys are enabled in kernel image. The Following kernel logs ensures that secure key and encrypted key is successful registered.

```
[ 6.893635] Key type trusted registered  
[ 6.905123] Key type encrypted registered
```

- IMA EVM is enabled in the kernel image. The following kernel logs ensures IMA EVM is enabled.

```
[ 6.909218] ima: No TPM chip found, activating TPM-bypass!  
[ 6.914738] ima: Allocated hash algorithm: sha1  
[ 6.962804] evm: HMAC attrs: 0x1
```

- System is up in enforce mode. The following logs from initramfs and kernel ensures enforce mode is enabled.

```
[ 8.248060] EXT4-fs (mmcblk0p2): mounted filesystem with ordered data  
mode. Opts: (null). Quota mode: none.  
Loading blobs  
[ 8.294368] evm: key initialized
```

- EVM attributes over a file can be checked using `getfattr` utility.

```
root@imx8ulpevk:~# getfattr -d -m . /path/to/file
```

- Security attribute are appraised successfully upon changing any file contents. The following commands verify the appraise functionality.

```
root@imx8ulpevk:~# vim test_file // write contents "abc"  
root@imx8ulpevk:~# getfattr -d -m . /path/to/test_file  
root@imx8ulpevk:~# vim test_file // write contents "abcd"  
root@imx8ulpevk:~# getfattr -d -m . /path/to/test_file
```

## 10.9 Security reference design

The NXP Security Reference Design initiative aims to help customers enable/configure security features through the Yocto build process. This framework is intended to ease the utilization and modification of security features in the NXP processors.

The following sections describe the various enablement as part of the Security Reference Design framework.

### 10.9.1 Automated image signing for secure boot

**Note:** See [meta layer documentation](#) for the information on the supported devices and supported distro for this release.

Secure boot is an industry standard to ensure that the device boots a trusted OEM software. NXP i.MX devices support Root of Trust (RoT) through the secure boot method using the OEM trusted root keys. In general, the secure boot mechanism involves signing and authentication of Bootloader and OS kernel image.

The signing method involves determining the part of the boot image that needs to be signed by analyzing the build log and then using [NXP Code Signing Tool](#). This method is usually found to be manual and error prone causing signing/authentication failure, which may eventually lead to boot failures. To eliminate such errors, an automated method is devised, which analyzes the input boot image and signs it using CST.

The NXP BSP release contains a `meta-nxp-security-reference-design/meta-secure-boot` Yocto meta layer, which supports i.MX boot image signing automation. The usage of this meta layer is described in the following sections.

#### 10.9.1.1 NXP CST Signer

**Note:** See [NXP CST Signer Tool](#) for more documentation.

The NXP CST Signer Tool created by NXP, analyzes the input NXP BSP image to extract the offset and size of the image(s) that need to be signed and prepares the corresponding Command Sequence File for CST to sign. This tool is used in the meta layer to support image signing. However, it can also be used as a standalone tool.

The NXP CST Signer tool has the following properties:

- Supports signing both HAB (i.MX 6/7/8M Family) and AHAB (i.MX 8/8x/8ULP/9 Family) devices' images.
- Analyzes input image to sign IVT/FIT/Container format images.
- Extracts offsets and sizes from the input image and constructs CSFs.
- Default configuration files are present in the CST Signer repository, filled with the basic information related to keys, certificate and flags to be used, both for HAB and AHAB devices.

#### 10.9.1.2 Prerequisites for preparing a signed image

The prerequisites for preparing a signed image are as follows:

1. Download the [NXP Code Signing Tool](#) delivered by NXP, which is required for this automation to work.
2. Prepare the keys using CST.

By default, the NXP CST Signer Tool uses standard keys of type `ECC_P256-SHA256` for i.MX 8/8x/8ULP/9 Family and `RSA_2048-SHA256` for i.MX 6/7/8M Family, to be available in the download location of CST. Follow the CST User Guide available in the CST package to generate the keys, certificates, SRK table/fuses and for more information.

**Note:** (Optional) Create and populate `csf_hab4.cfg` and/or `csf_ahab.cfg` with the preferred key type at the CST location to use your preferred PKI tree. The default configuration files are located at the CST Signer work directory in Yocto build.

### 10.9.1.3 Yocto setup for secure boot build

**Note:** See the *i.MX Yocto Project User's Guide* ([IMXLXYOCTOUG](#)) for how to set up and build Yocto project.

To set up the Yocto project for secure boot build, perform the following steps:

1. Set up Yocto Build Environment and Configuration.

```
repo init -u https://github.com/nxp-imx/imx-manifest -b imx-linux-nanbiel -m
imx-6.6.3-1.0.0_security-reference-design.xml
repo sync
DISTRO=<DISTRO> MACHINE=<MACHINE> source imx-setup-release.sh -b <build
directory>
```

2. Add the meta-secure-boot layer to the Yocto project.

```
bitbake-layers add-layer ../sources/meta-nxp-security-reference-design/meta-
secure-boot
```

3. Add CST in CST\_PATH in local.conf.

**Note:** The absolute location of CST is required.

```
echo "CST_PATH = \"<_absolute_location_ to cst package>\"" >> conf/local.conf
```

### 10.9.1.4 Generating a signed bootloader/kernel/WIC image in Yocto project

To generate a signed bootloader/kernel/WIC image in Yocto project, perform the following steps:

1. Build a signed WIC image.

```
bitbake core-image-minimal-secure-boot
```

2. Build a signed imx-boot bootloader (for i.MX 8M/8/8x/8ULP/9x).

```
bitbake imx-boot-signature
```

3. Build a signed U-Boot bootloader (for i.MX 6/7).

```
bitbake u-boot-signature
```

4. Build a signed Linux kernel image.

```
bitbake linux-imx-signature
```

### 10.9.1.5 Booting a signed image

The output of the Yocto build contains three signed artifacts:

- Signed Bootloader
- Signed Kernel image
- SDcard (WIC) image (Contains signed bootloader and signed kernel images only)

Either of the signed bootloader or kernel image can be downloaded to the target based on the development scenario. The signed WIC image is provided to deploy the signed bootloader and kernel artifacts to the device.

- Secure boot in OPEN/OEM OPEN lifecycle

It is recommended to download the signed image in the OPEN lifecycle state and verify secure boot before closing the part. For more information on how to program the SRK Fuses, verifying signature and closing the part to enable secure boot, see the secure boot user guide, based on the SoC, at [HAB4 UBoot Guide](#) or [AHAB UBoot Guides](#).

- Secure boot in CLOSED/OEM CLOSED lifecycle

When the SoC is in CLOSED lifecycle state, the same pre-provisioned signed image must boot the device in a closed security state ensuring a trusted image is running on the device.

## 11 Connectivity

This section describes the connectivity for Bluetooth wireless technology and Wi-Fi, as well as for USB type-C.

### 11.1 Connectivity for Bluetooth wireless technology and Wi-Fi

Bluetooth and Wi-Fi are supported on i.MX through on-board chip solutions and external hardware. The following table lists the various on-board chips and external solutions.

**Table 79. On-board chips and external solutions for Bluetooth and Wi-Fi support**

SoC	On-board chip	PCIe M.2 card	uSD card or SDIO M.2 card
8QuadXPlus/8DXL	-	NXP PCIe 88W9098 (tested with Murata LBEE5ZZ1XL)	-
8QuadMax	-	NXP PCIe 88W9098 (tested with Murata LBEE5ZZ1XL)	-
8M Quad	-	NXP 88W8997 (tested with Murata LBEE5XV1YM) On i.MX 8M Quad WEVK board (use M.2 on the bottom side): NXP PCIe 88W9098 (tested with Murata LBEE5ZZ1XL).	-
8M Nano	NXP 88W8987 (tested with AzureWave AW-CM358SM)	-	NXP SDIO IW612 (tested with Murata LBES5PL2EL)
8M Mini	NXP 88W8987 (tested with AzureWave AW-CM358SM)	-	-
7ULP	-	-	NXP 88W8987 (tested with Murata LBEE5QD1ZM)
7Dual	-	-	NXP 88W8987 (tested with Murata LBEE5QD1ZM)
6QuadPlus/Quad/Dual/Solo	-	-	NXP 88W8987 (tested with Murata LBEE5QD1ZM)
6SLL/6UltraLite/6ULL/6ULZ	-	-	NXP 88W8987 (tested with Murata LBEE5QD1ZM) NXP SDIO IW416 (tested with Murata LBEE5CJ1XK) NXP SDIO 88W8801 (tested with Murata LBWA0ZZ2DS) NXP SDIO IW612 (tested with Murata LBES5PL2EL)
8M Plus	-	NXP 88W8997 (tested with AW-CM276MAPUR) NXP PCIe 88W9098 (tested with Murata LBEE5ZZ1XL).	NXP SDIO 88W8997 (tested with Murata LBEE5XV1YM) NXP SDIO 88W9098 (tested with Murata LBEE5ZZ1XL)
8ULP	-	-	NXP SDIO IW416 (tested with Murata LBEE5CJ1XK)

Table 79. On-board chips and external solutions for Bluetooth and Wi-Fi support...continued

SoC	On-board chip	PCIe M.2 card	uSD card or SDIO M.2 card
i.MX 91P	-	-	NXP SDIO IW612 (tested with Murata LBES5PL2EL)
i.MX 93	-	-	NXP SDIO IW612 (tested with Murata LBES5PL2EL)
i.MX 95	-	On i.MX 95 19x19 EVK board: NXP PCIe 88W9098 (tested with U-Blox JODY-W3).	-

**Note:** All Murata LBEE5QD1ZM are tested on i.MX 6/i.MX 7 platforms along with the Murata M.2-to-usd adapter.

The wireless driver supports wpa\_supplicant, which is a WEP/WPA/WPA2/WPA3 encryption authenticated tool.

- Wi-Fi driver: supports NXP 88W8987-based modules with SDIO interface, NXP 88W9098-based modules with PCIe and SDIO interfaces, NXP 88W8997-based modules with PCIe and SDIO interfaces, NXP IW416-based modules with SDIO interface, NXP 88W8801-based modules with SDIO interface, and NXP IW612-based modules with SDIO interface.
- Firmware  
The NXP release package already includes all NXP, Wi-Fi/Bluetooth firmware. It requires to accept NXP license.

To run Wi-Fi, execute the following commands first and follow common commands below:

- For the following steps, execute these commands using [connman](#)

```
# For all the Wi-Fi modules:
modprobe moal mod_para=nxp/wifi_mod_para.conf
$connmanctl
$connmanctl> enable wifi
$connmanctl> scan wifi
$connmanctl> services /* This should list of the network. For example
wifi_c0e4347f5053_4a62726f_managed_psk*/
$connmanctl> agent on
$connmanctl> connect wifi_c0e4347f5053_4a62726f_managed_psk /* Enter Passphrase
*/
Agent RequestInput wifi_c0e4347f5053_4a62726f_managed_psk
Passphrase = [ Type=psk, Requirement=mandatory ]
Passphrase?
$connmanctl> quit
```

To run NXP Bluetooth with BlueZ stack, execute the following commands (it requires load Wi-Fi first to load Bluetooth firmware):

```
modprobe btnxpuart
hciconfig hci0 up
```

Run the following commands to connect the Bluetooth device for all chips:

```
$ bluetoothctl
[bluetooth]# default-agent
[bluetooth]# agent on
[bluetooth]# scan on
[bluetooth]# pair xx:xx:xx:xx:xx:xx
[BT dev]# connect xx:xx:xx:xx:xx:xx
```

```
[BT dev]# quit
```

**Note:**

*MuRata has two kinds of 88W9098 1XL modules with no visual difference between them. The old version 1XL sets the initial baud rate of Bluetooth firmware to 3 Mbps, and the new version 1XL sets it to 115200 bps.*

*BSP release supports the new 1XL module (115200 bps) by default. To use the old 1XL module (3 Mbps), add the `fw-init-baudrate = <3000000>` property in Bluetooth device node of the dts file to make it work.*

The i.MX 6 boards require board rework to support the Bluetooth/Wi-Fi enablement as well as running with the Bluetooth/Wi-Fi device tree. The following is a list of the hardware modifications required and possibly conflicts caused by these modifications.

- i.MX 6QuadPlus/Quad/Dual/DualLite/Solo: See <https://community.nxp.com/docs/DOC-94235>. This change HAS a pin conflict with: EPDC/SPI-NOR/GPIO-LED.
- i.MX 6SoloX: Install R328, and disconnect R327. Connect with SD2 slot and BLUETOOTH CABLE CONNECTOR J19. It has no Pin conflict with other modules.
- i.MX 6SLL: Install R127, and double check to ensure R126 and R128 are installed. Connect with SD3 slot and BLUETOOTH CABLE CONNECTOR J4. It has no Pin conflict with other modules.
- i.MX 6UL/ULL/ULZ: Install R1701. It has no Pin conflict with other modules.

Rework is also required to support NXP PCIe 88W9098 on i.MX 8M Plus.

- To run NXP PCIe 88W9098 on i.MX 8M Plus, perform the hardware rework as follows:  
Change R452 to 0 ohm.

## 11.2 Connectivity for USB type-C

The following describes the connectivity for USB type-C and power delivery connection on the i.MX 8QuadXPlus MEK board.

- The Linux release includes USB type-C and PD stack, which is enabled by default. The specific power parameters are passed in by DTS. The following `fs1-imx8qxp-mek` is an example:

```
typec_ptn5110: typec@50 {
    compatible = "usb,tcpci";
    pinctrl-names = "default";
    pinctrl-0 = <&pinctrl_typec>;
    reg = <0x50>;
    interrupt-parent = <&gpio1>;
    interrupts = <3 IRQ_TYPE_LEVEL_LOW>;
    ss-sel-gpios = <&gpio5 9 GPIO_ACTIVE_LOW>;
    reset-gpios = <&pca9557_a 7 GPIO_ACTIVE_HIGH>;
    src-pdos = <0x380190c8>;
    snk-pdos = <0x380190c8 0x3802d0c8>;
    max-snk-mv = <9000>;
    max-snk-ma = <1000>;
    op-snk-mw = <9000>;
    port-type = "drp";
    sink-disable;
    default-role = "source";
    status = "okay";
};
```

For power capability related configuration, users need to check the PD specification to see how to composite the PDO value. To make it support power source role for more voltages, specify the source PDO. The i.MX 8QuadXPlus board can support 5 V and 12 V power supply.



- Users can use `/sys/kernel/debug/tcpm/2-0050` to check the power delivery state, which is for debugging purpose information.

The following describes the connectivity for USB type-C and power delivery connection on the i.MX 95 EVK board.

- The Linux release includes USB type-C and PD stack, which are enabled by default. The specific power parameters are passed in by DTS. The following takes i.MX 95 EVK as an example:

```
ptn5110: tcpc@50 {
    compatible = "nxp,ptn5110";
    reg = <0x50>;
    interrupt-parent = <&gpio5>;
    interrupts = <14 IRQ_TYPE_LEVEL_LOW>;
    pinctrl-names = "default";
    pinctrl-0 = <&pinctrl_ptn5110>;

    typec_con: connector {
        compatible = "usb-c-connector";
        label = "USB-C";
        power-role = "dual";
        data-role = "dual";
        try-power-role = "sink";
        source-pdos = <PDO_FIXED(5000, 3000, PDO_FIXED_USB_COMM)>;
        sink-pdos = <PDO_FIXED(5000, 3000, PDO_FIXED_USB_COMM)
            PDO_VAR(5000, 20000, 3000)>;
        op-sink-microwatt = <15000000>;
        self-powered;
    };
};
```

For power capability related configuration, users need to check the PD specification to see how to composite the PDO value. To make it support power source role for more voltages, specify the source PDO. The i.MX 95 EVK board only supports 5V supply.

- Users can use `/sys/kernel/debug/usb/tcpm-6-0050/log` to check the power delivery state, which is for debugging purpose information.
- Booting only by type-C port power supply is not supported.

### 11.3 NXP Bluetooth/Wi-Fi information

The NXP Bluetooth/Wi-Fi information is as follows:

- SoC version: SDIO 88W8987, PCIe 88W8997, SDIO 88w8997, PCIe 88w9098, SDIO 88W9098, SDIO IW416, SDIO 88W8801, SDIO IW612
- SDIO W8801 Firmware version: 14.92.36.p188
- SDIO-UART IW416 Firmware version: 16.92.21.p119.2
- PCIE-UART W9098 Firmware version: 17.92.1.p149.131
- SDIO-UART W8997 Firmware version: 16.92.21.p119.2
- PCIE-UART W8997 Firmware version: 116.92.21.p119.2
- SDIO-UART W8987 Firmware version: 16.92.21.p119.2
- SDIO-UART W9098 Firmware version: 17.92.1.p149.131
- SDIO-UART IW612 Firmware version: 18.99.2.p66.17
- Wi-Fi/Bluetooth firmware version: for example, 16.92.10.p210
  - 16: Major revision
  - 92: Feature pack
  - 10: Release version

- p210: Patch number
- For all Wi-Fi modules, Driver version: MXM6x17437.p3-MGPL
  - 6X: Linux 6.x
  - 17437: Release version
  - p3: Patch number
  - MGPL: General

Tested using iPerf3 version 3.15.

### 11.4 Hardware limitations

i.MX 8M Mini and Nano baseboards do not route SDIO, UART, and I2S to the M.2 Key-E connector, so it is not possible to use SDIO/UART/I2S wireless cards on these boards.

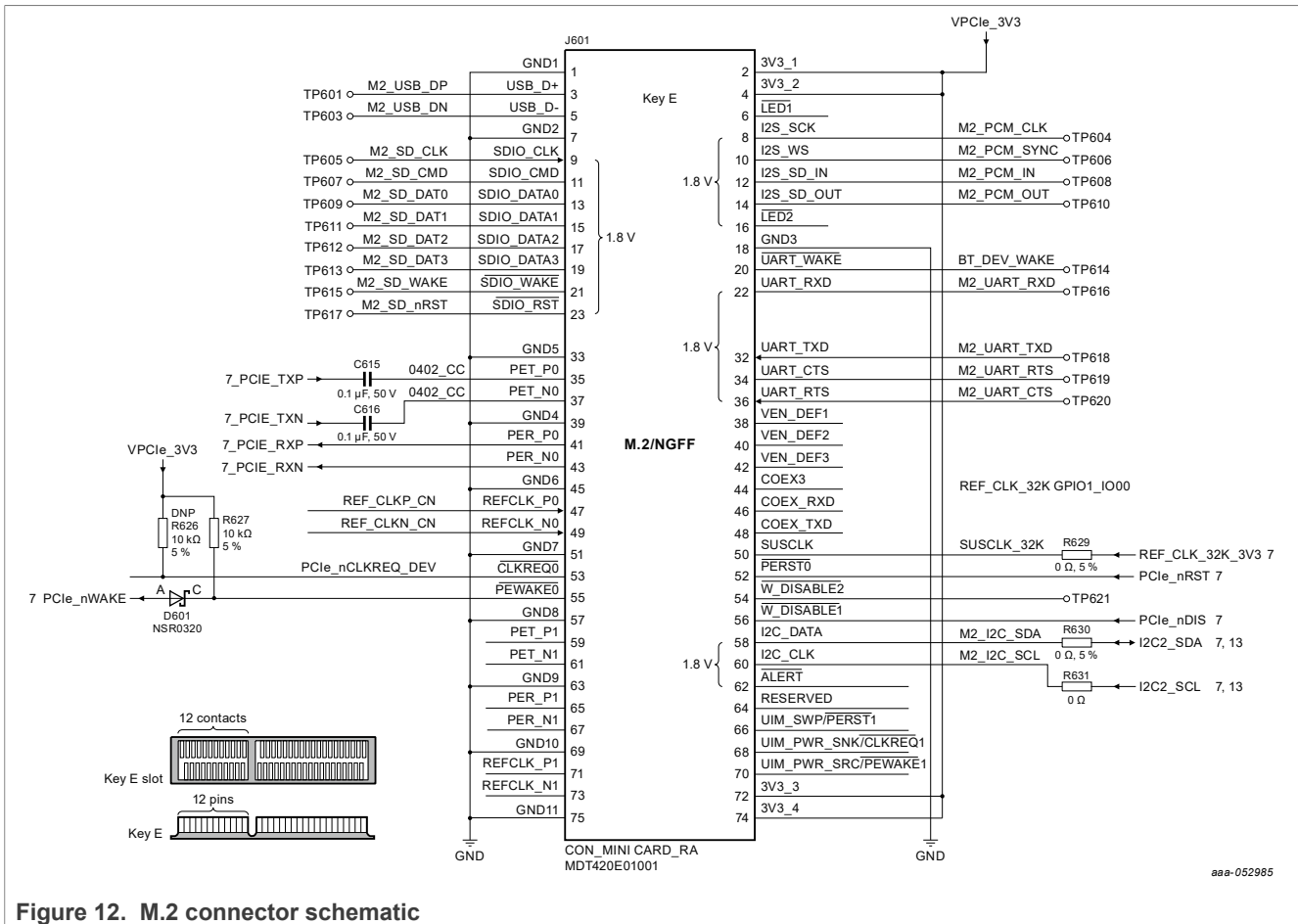

Figure 12. M.2 connector schematic

### Workarounds

Use an M.2 adapter to do a physical connection to bring SDIO, UART, and I2S signals to the J1003 connector. With this, it is required to modify the device tree to enable these new modules.

### 11.5 Certification

### 11.5.1 WFA certification

The following table lists the WFA certification.

Table 80. WFA certification

STA	Certification
STA	802.11n
STA	802.11ac
STA	WPS2.0
STA	PMF
STA	WMM-PS
STA	WPA3

For details, see [Wi-Fi Alliance Derivative Certification \(AN12976\)](#).

### 11.5.2 Bluetooth controller certification

Listing details: <https://launchstudio.bluetooth.com/ListingDetails/115533>

## 12 DDR Performance Monitor

### 12.1 Introduction

There are counters in some i.MX 8 DDR controllers, which are used to monitor DDR signals. Some signals can help users monitor DDR transactions and calculate DDR bandwidth.

### 12.2 Frequently used events

The following events are frequently used to monitor DDR transactions for different platforms.

- i.MX 8QuadMax/8QuadXPlus/8M Quad/8M Mini/8M Nano: cycles, read-cycles, write-cycles
- i.MX 8M Plus: axid-read, axid-write
- i.MX 8DXL: cycles, read-cycles, write-cycles, axid-read, axid-write

**Note:**

- *i.MX 8M Plus and 8DXL support AXI ID filtering.*
- *For i.MX 8M Plus, cycles, read-cycles, write-cycles cannot be used since there is a hardware bug that leads to counter overflow.*

### 12.3 Showing supported events

Run the following commands to show the supported events:

```
# perf list pmu | grep imx8_ddr
imx8_ddr0/activate/ [Kernel PMU event]
imx8_ddr0/axid-read/ [Kernel PMU event]
imx8_ddr0/axid-write/ [Kernel PMU event]
imx8_ddr0/cycles/ [Kernel PMU event]
imx8_ddr0/hp-read-credit-cnt/ [Kernel PMU event]
imx8_ddr0/hp-read/ [Kernel PMU event]
```

```

imx8_ddr0/hp-req-nocredit/ [Kernel PMU event]
imx8_ddr0/hp-xact-credit/ [Kernel PMU event]
imx8_ddr0/load-mode/ [Kernel PMU event]
imx8_ddr0/lp-read-credit-cnt/ [Kernel PMU event]
imx8_ddr0/lp-req-nocredit/ [Kernel PMU event]
imx8_ddr0/lp-xact-credit/ [Kernel PMU event]
imx8_ddr0/perf-mwr/ [Kernel PMU event]
imx8_ddr0/precharge/ [Kernel PMU event]
imx8_ddr0/raw-hazard/ [Kernel PMU event]
imx8_ddr0/read-accesses/ [Kernel PMU event]
imx8_ddr0/read-activate/ [Kernel PMU event]
imx8_ddr0/read-command/ [Kernel PMU event]
imx8_ddr0/read-cycles/ [Kernel PMU event]
imx8_ddr0/read-modify-write-command/ [Kernel PMU event]
imx8_ddr0/read-queue-depth/ [Kernel PMU event]
imx8_ddr0/read-write-transition/ [Kernel PMU event]
imx8_ddr0/read/ [Kernel PMU event]
imx8_ddr0/refresh/ [Kernel PMU event]
imx8_ddr0/selfresh/ [Kernel PMU event]
imx8_ddr0/wr-xact-credit/ [Kernel PMU event]
imx8_ddr0/write-accesses/ [Kernel PMU event]
imx8_ddr0/write-command/ [Kernel PMU event]
imx8_ddr0/write-credit-cnt/ [Kernel PMU event]
imx8_ddr0/write-cycles/ [Kernel PMU event]
imx8_ddr0/write-queue-depth/ [Kernel PMU event]
imx8_ddr0/write/ [Kernel PMU event]

```

## 12.4 Examples for monitoring transactions

This section shows some examples to monitor DDR transactions.

- For i.MX 8QuadMax/8QuadXPlus/8M Quad/8M Mini/8M Nano:

```
# perf stat -a -I 1000 -e imx8_ddr0/cycles/,imx8_ddr0/read-cycles/,imx8_ddr0/
write-cycles/
```

- For i.MX 8M Plus:

– All masters:

```
# perf stat -a -I 1000 -e imx8_ddr0/axid-read,axi_mask=0xffff/,imx8_ddr0/
axid-write,axi_mask=0xffff/
```

– GPU 3D:

```
# perf stat -a -I 1000 -e imx8_ddr0/axid-read,axi_id=0x70/,imx8_ddr0/axid-
write,axi_id=0x70/
```

– LCDIF1:

```
# perf stat -a -I 1000 -e imx8_ddr0/axid-read,axi_id=0x68/,imx8_ddr0/axid-
write,axi_id=0x68/
```

- For i.MX 8DXL:

– All masters:

```
# perf stat -a -I 1000 -e imx8_ddr0/cycles/,imx8_ddr0/read-cycles/,imx8_ddr0/
write-cycles/
# perf stat -a -I 1000 -e imx8_ddr0/axid-read,axi_mask=0xffff/,imx8_ddr0/
axid-write,axi_mask=0xffff/
```

**- USB 2.0:**

```
# perf stat -a -I 1000 -e imx8_ddr0/axid-
read,axi_mask=0xb0,axi_id=0x40b/,imx8_ddr0/axid-
write,axi_mask=0xb0,axi_id=0x40b/
```

**- USDHC0:**

```
# perf stat -a -I 1000 -e imx8_ddr0/axid-read,axi_id=0x1b/,imx8_ddr0/axid-
write,axi_id=0x1b/
```

## 12.5 Performance metric

Try to use metric instead of event if event command line is too cumbersome to you. The following is the example on i.MX 8QuadXPlus.

### 12.5.1 Showing supported metric

Run the following commands to show the supported metric:

```
# perf list metric
List of pre-defined events (to be used in -e):
Metrics:
imx8qxp_bandwidth_usage.lpddr4
    [bandwidth usage for lpddr4 mek board. Unit: imx8_ddr ]
imx8qxp_ddr_read.all
    [bytes all masters read from ddr based on read-cycles event. Unit:
    imx8_ddr ]
imx8qxp_ddr_write.all
    [bytes all masters write to ddr based on write-cycles event. Unit:
    imx8_ddr ]
```

### 12.5.2 Monitoring transactions

Run the following commands to monitor transactions:

```
# perf stat -a -I 1000 -M imx8qxp_ddr_read.all,imx8qxp_ddr_write.all
# time counts unit events
1.001115250 28264 imx8_ddr0/read-cycles/ # 441.6 KB imx8qxp_ddr_read.all
1.001115250 11622 imx8_ddr0/write-cycles/ # 181.6 KB imx8qxp_ddr_write.all
2.002718000 14496 imx8_ddr0/read-cycles/ # 226.5 KB imx8qxp_ddr_read.all
2.002718000 4585 imx8_ddr0/write-cycles/ # 71.6 KB imx8qxp_ddr_write.all
```

## 12.6 DDR Performance usage summary

It is recommended to use metric to monitor DDR transactions, as it is more convenient. You can get DDR bandwidth of all masters or specific master directly without doing extra calculations. Especially on platforms that support AXI ID filtering, get rid of searching masters' ID.

## 13 One-Time Programmable Controller Driver Using NVMEM Subsystem

## 13.1 Introduction

The One-Time Programmable Controller driver is realized with the NVMEM Subsystem, which introduces DT representation for consumer devices to get the data they require (MAC addresses, SoC/Revision ID, part numbers, and so on) from the NVMEMs.

## 13.2 NVMEM provider OCOTP

Use struct `nvmem_config` to set the configuration of the NVMEM device OCOTP. This structure can define callback to read/write the eFUSE data.

In the read/write function prototype:

- The 1st parameter is the private data of the OCOTP device, and it contains a pointer to the remapped memory.
- The 2nd parameter is from the first data in property reg of a NVMEM consumer, and this offset represents the OCOTP shadow register, to which a eFuse address is mapped.
- The 3rd parameter returns the read data when reading or passes the data to write when writing.
- The 4th parameter, which indicates how many bytes to read/write, is from the second data in property reg of a NVMEM consumer.

```
typedef int (*nvmem_reg_read_t)(void *priv, unsigned int offset, void *val,
    size_t bytes);
typedef int (*nvmem_reg_write_t)(void *priv, unsigned int offset, void *val,
    size_t bytes);
```

## 13.3 NVMEM consumer

NVMEM consumers are the entities that make use of the NVMEM provider to read from and to NVMEM. In the DTS file, the NVMEM consumer node needs to be written in the NVMEM provider node. The indispensable property is `reg`. The first data represents the offset of the OCOTP shadow register, to which a eFuse address is mapped. The second data indicates the number of bytes to read or write.

Take the MAC address on i.MX 8M Nano as an example:

The first data in `reg` is `0x90`,  $0x400 + 0x90 * 0x4 = 0x640$ , `0x640` is the first Fuse address of `MAC_ADDR`. `0x4` represents 4 bytes.

## 13.4 Examples to read/write the raw NVMEM file in user space

- i.MX 6/i.MX 7/i.MX 8M Mini/8M Nano/8M Plus/8M Quad

```
# hexdump /sys/bus/nvmem/devices/imx-ocotp0/nvmem
```

- i.MX 8ULP

```
# hexdump /sys/bus/nvmem/devices/fsb_s400_fuse1/nvmem
```

- i.MX 8M Plus

```
f = open('/sys/devices/platform/30350000.ocotp-ctrl/imx-ocotp0/nvmem', 'br+')
f.seek(0x90) # MAC1_ADDR
f.write(pack('<L', 0x30445011))
f.close()
```

## 14 NXP eIQ Machine Learning

The NXP eIQ machine learning software development environment enables the use of machine learning algorithms on i.MX family SoCs. The eIQ software for i.MX includes inference engines, optimized libraries for hardware acceleration, and an ML security package.

The main eIQ toolkit is integrated in the Yocto BSP, contained in meta-imx/meta-ml layer. The following inference engines are currently supported: TensorFlow Lite, ONNX Runtime, OpenCV, DeepViewRT, and PyTorch. See the *i.MX Machine Learning User's Guide* (IMXMLUG) for details about the eIQ software development environment.

In addition to the toolkit integrated in the Yocto BPS, there is an ML security package delivered separately. See also [Security for Machine Learning Package \(AN12867\)](#).

## 15 Murata Wi-Fi/Bluetooth Solutions

Table 81. Murata Wi-Fi/Bluetooth solutions with NXP chipsets

NXP chipset	Murata module (Part number)	Embedded Artists M.2 EVB
88W8801	Type 2DS ( <a href="#">LBWA0ZZ2DS</a> )	 <p>2DS M.2 Module rev PA1</p> <p><a href="#">EAR00386</a></p>
IW416	Type 1XK ( <a href="#">LBEE5CJ1XK</a> )	 <p>1XK M.2 rev PA2</p> <p><a href="#">EAR00385</a></p>
88W8987	Type 1ZM ( <a href="#">LBEE5QD1ZM</a> )	 <p>1ZM M.2 rev B</p> <p><a href="#">EAR00364</a></p>
88W8997	Type 1YM ( <a href="#">LBEE5XV1YM</a> )	 <p>1YM M.2 rev M1</p> <p><a href="#">EAR00370</a></p>

Table 81. Murata Wi-Fi/Bluetooth solutions with NXP chipsets...continued

NXP chipset	Murata module (Part number)	Embedded Artists M.2 EVB
88W9098	Type 1XL ( <a href="#">LBEE5ZZ1XL</a> )	 <p><a href="#">EAR00387</a></p>

Table 82. Murata Wi-Fi/Bluetooth solutions for NXP and Embedded Artists EVKs

EVK	Murata module	Interconnect	Embedded Artists M.2 Module Part #
<a href="#">NXP i.MX 8QuadMax</a>	<a href="#">Type 1YM</a> (PCIe)	M.2	<a href="#">EAR00370</a>
	<a href="#">Type 1XL</a> (PCIe)	M.2	<a href="#">EAR00387</a>
<a href="#">NXP i.MX 8QuadXPlus</a>	<a href="#">Type 1YM</a> (PCIe)	M.2	<a href="#">EAR00370</a>
	<a href="#">Type 1XL</a> (PCIe)	M.2	<a href="#">EAR00387</a>
<a href="#">NXP i.MX 8M</a>	<a href="#">Type 1XK</a>	<a href="#">uSD-M.2</a>	<a href="#">EAR00385</a>
	<a href="#">Type 1ZM</a>	<a href="#">uSD-M.2</a>	<a href="#">EAR00364</a>
	<a href="#">Type 1YM</a> (SDIO <sup>[1]</sup> )	<a href="#">uSD-M.2</a>	<a href="#">EAR00370</a>
	<a href="#">Type 1XL</a> (SDIO <sup>[1]</sup> )	<a href="#">uSD-M.2</a>	<a href="#">EAR00387</a>
	<a href="#">Type 1YM</a> (PCIe)	M.2	<a href="#">EAR00370</a>
	<a href="#">Type 1XL</a> (PCIe)	M.2	<a href="#">EAR00387</a>
<a href="#">NXP i.MX 8DXL</a>	<a href="#">Type 1YM</a> (PCIe)	M.2	<a href="#">EAR00370</a>
	<a href="#">Type 1XL</a> (PCIe)	M.2	<a href="#">EAR00387</a>
<a href="#">NXP i.MX 8M Plus</a>	<a href="#">Type 1XK</a>	M.2	<a href="#">EAR00385</a>
	<a href="#">Type 1ZM</a>	M.2	<a href="#">EAR00364</a>
	<a href="#">Type 1YM</a> (SDIO <sup>[1]</sup> )	M.2	<a href="#">EAR00370</a>
	<a href="#">Type 1XL</a> (SDIO <sup>[1]</sup> )	M.2	<a href="#">EAR00387</a>
	<a href="#">Type 1YM</a> (PCIe)	M.2	<a href="#">EAR00370</a>
	<a href="#">Type 1XL</a> (PCIe)	M.2	<a href="#">EAR00387</a>
<a href="#">NXP i.MX 8M Mini LPDDR4</a>	<a href="#">Type 1XK</a>	<a href="#">uSD-M.2</a>	<a href="#">EAR00385</a>
	<a href="#">Type 1ZM</a>	<a href="#">uSD-M.2</a>	<a href="#">EAR00364</a>
	<a href="#">Type 1YM</a> (SDIO <sup>[1]</sup> )	<a href="#">uSD-M.2</a>	<a href="#">EAR00370</a>
	<a href="#">Type 1XL</a> (SDIO <sup>[1]</sup> )	<a href="#">uSD-M.2</a>	<a href="#">EAR00387</a>
	<a href="#">Type 1YM</a> (PCIe)	M.2	<a href="#">EAR00370</a>
	<a href="#">Type 1XL</a> (PCIe)	M.2	<a href="#">EAR00387</a>
<a href="#">NXP i.MX 8M Nano LPDDR4</a>	<a href="#">Type 1XK</a>	<a href="#">uSD-M.2</a>	<a href="#">EAR00385</a>
	<a href="#">Type 1ZM</a>	<a href="#">uSD-M.2</a>	<a href="#">EAR00364</a>

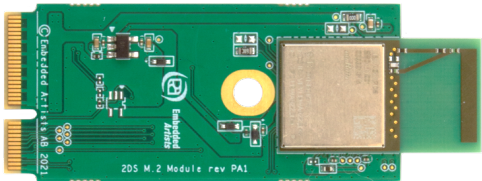
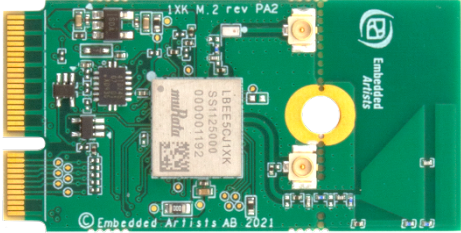
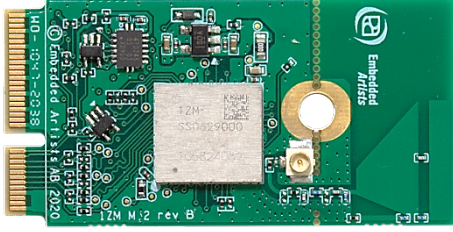
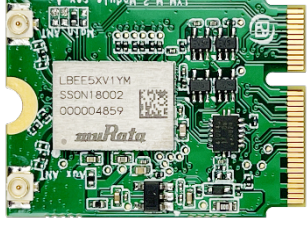

Table 82. Murata Wi-Fi/Bluetooth solutions for NXP and Embedded Artists EVKs...continued

EVK	Murata module	Interconnect	Embedded Artists M.2 Module Part #
	<a href="#">Type 1YM</a> (SDIO <sup>[1]</sup> )	<a href="#">uSD-M.2</a>	<a href="#">EAR00370</a>
	<a href="#">Type 1XL</a> (SDIO <sup>[1]</sup> )	<a href="#">uSD-M.2</a>	<a href="#">EAR00387</a>
<a href="#">NXP i.MX 7Dual</a>	<a href="#">Type 1XK</a>	<a href="#">uSD-M.2</a>	<a href="#">EAR00385</a>
	<a href="#">Type 1ZM</a>	<a href="#">uSD-M.2</a>	<a href="#">EAR00364</a>
	<a href="#">Type 1YM</a> (SDIO <sup>[1]</sup> )	<a href="#">uSD-M.2</a>	<a href="#">EAR00370</a>
<a href="#">NXP i.MX 7ULP</a>	<a href="#">Type 1XK</a>	<a href="#">uSD-M.2</a>	<a href="#">EAR00385</a>
	<a href="#">Type 1ZM</a>	<a href="#">uSD-M.2</a>	<a href="#">EAR00364</a>
<a href="#">NXP i.MX 6QuadPlus</a>	<a href="#">Type 1XK</a>	<a href="#">uSD-M.2</a>	<a href="#">EAR00385</a>
<a href="#">NXP i.MX 6Quad</a>	<a href="#">Type 1YM</a> (SDIO <sup>[1]</sup> )	<a href="#">uSD-M.2</a>	<a href="#">EAR00370</a>
<a href="#">NXP i.MX 6DL</a>			
<a href="#">NXP i.MX 6SLL</a>	<a href="#">Type 1XK</a>	<a href="#">uSD-M.2</a>	<a href="#">EAR00385</a>
<a href="#">NXP i.MX 6UL</a>	<a href="#">Type 1ZM</a>	<a href="#">uSD-M.2</a>	<a href="#">EAR00364</a>
<a href="#">NXP i.MX 6ULL/ULZ</a>	<a href="#">Type 1YM</a> (SDIO <sup>[1]</sup> )	<a href="#">uSD-M.2</a>	<a href="#">EAR00370</a>

[1] Default strapping option on Embedded Artists 1YM/1XL M.2 module is WLAN-PCle. Refer to Embedded Artists datasheet on how to modify strapping on M.2 module for WLAN-SDIO configuration.

## 16 Note About the Source Code in the Document

Example code shown in this document has the following copyright and BSD-3-Clause license:

Copyright 2024 NXP Redistribution and use in source and binary forms, with or without modification, are permitted provided that the following conditions are met:

1. Redistributions of source code must retain the above copyright notice, this list of conditions and the following disclaimer.
2. Redistributions in binary form must reproduce the above copyright notice, this list of conditions and the following disclaimer in the documentation and/or other materials provided with the distribution.
3. Neither the name of the copyright holder nor the names of its contributors may be used to endorse or promote products derived from this software without specific prior written permission.

THIS SOFTWARE IS PROVIDED BY THE COPYRIGHT HOLDERS AND CONTRIBUTORS "AS IS" AND ANY EXPRESS OR IMPLIED WARRANTIES, INCLUDING, BUT NOT LIMITED TO, THE IMPLIED WARRANTIES OF MERCHANTABILITY AND FITNESS FOR A PARTICULAR PURPOSE ARE DISCLAIMED. IN NO EVENT SHALL THE COPYRIGHT HOLDER OR CONTRIBUTORS BE LIABLE FOR ANY DIRECT, INDIRECT, INCIDENTAL, SPECIAL, EXEMPLARY, OR CONSEQUENTIAL DAMAGES (INCLUDING, BUT NOT LIMITED TO, PROCUREMENT OF SUBSTITUTE GOODS OR SERVICES; LOSS OF USE, DATA, OR PROFITS; OR BUSINESS INTERRUPTION) HOWEVER CAUSED AND ON ANY THEORY OF LIABILITY, WHETHER IN CONTRACT, STRICT LIABILITY, OR TORT (INCLUDING NEGLIGENCE OR OTHERWISE) ARISING IN ANY WAY OUT OF THE USE OF THIS SOFTWARE, EVEN IF ADVISED OF THE POSSIBILITY OF SUCH DAMAGE.

## 17 Revision History

This table provides the revision history.

## Revision history

Document ID	Release date	Description
IMXLUG v.LF6.6.3_1.0.0	29 March 2024	Upgraded to the 6.6.3 kernel, removed the i.MX 91P, and added the i.MX 95 as Alpha Quality.
IMXLUG v.LF6.1.55_2.2.0	12/2023	Updated a link in <a href="#">Section 10.9.1</a> .
IMXLUG v.LF6.1.55_2.2.0	12/2023	Upgraded to the 6.1.55 kernel.
IMXLUG v.LF6.1.36_2.1.0	09/2023	Upgraded to the 6.1.36 kernel.
IMXLUG v.LF6.1.22_2.0.0	08/2023	Changed "0x9F800" to "0x9F8000" in Section <a href="#">Section 4.3</a> .
IMXLUG v.LF6.1.22_2.0.0	07/2023	Updated a description in Section <a href="#">Section 4.3.4</a> .
IMXLUG v.LF6.1.22_2.0.0	06/2023	Upgraded to the 6.1.22 kernel.
IMXLUG v.LF6.1.1_1.0.00	03/2023	Upgraded to the 6.1.1 kernel.
IMXLUG v.LF5.15.71_2.2.0	12/2022	Upgraded to the 5.15.71 kernel.
IMXLUG v.LF5.15.52_2.1.0	09/2022	Upgraded to the 5.15.52 kernel, and added the i.MX 93.
IMXLUG v.LF5.15.32_2.0.0	06/2022	Upgraded to the 5.15.32 kernel, U-Boot 2022.04, and Kirkstone Yocto.
IMXLUG v.LF5.15.5_1.0.0	03/2022	Upgraded to the 5.15.5 kernel, Honister Yocto, and Qt6.
IMXLUG v.LF5.10.72_2.2.0	12/2021	Upgraded the kernel to 5.10.72 and updated the BSP.
IMXLUG v.LF5.10.52_2.1.0	10/2021	Added an appendix for Murata Wi-Fi/Bluetooth solutions.
IMXLUG v.LF5.10.52_2.1.0	09/2021	Updated for i.MX 8ULP Alpha and the kernel upgraded to 5.10.52.
IMXLUG v.LF5.10.35_2.0.0	06/2021	Upgraded Yocto Project to Hardknott and the kernel upgraded to 5.10.35.
IMXLUG v.LF5.10.9_1.0.0	03/2021	Upgraded Yocto Project to Gatesgarth and the kernel upgraded to 5.10.9.
IMXLUG v.L5.4.70_2.3.0	01/2021	Updated the command lines in Section "Running the Arm Cortex-M4 image".
IMXLUG v.L5.4.70_2.3.0	12/2020	i.MX 5.4 consolidated GA for release i.MX boards including i.MX 8M Plus and i.MX 8DXL.
IMXLUG v.L5.4.47_2.2.0	09/2020	i.MX 5.4 Beta2 release for i.MX 8M Plus, Beta for 8DXL, and consolidated GA for released i.MX boards.
IMXLUG v.L5.4.24_2.1.0	06/2020	i.MX 5.4 Beta release for i.MX 8M Plus, Alpha2 for 8DXL, and consolidated GA for released i.MX boards.
IMXLUG v.L5.4.3_2.0.0	04/2020	i.MX 5.4 Alpha release for i.MX 8M Plus and 8DXL EVK boards.
IMXLUG v.LF5.4.3_1.0.0	03/2020	i.MX 5.4 Kernel and Yocto Project Upgrades.
IMXLUG v.L4.19.35_1.1.0	10/2019	i.MX 4.19 Kernel and Yocto Project Upgrades.
IMXLUG v.L4.19.35_1.0.0	07/2019	i.MX 4.19 Beta Kernel and Yocto Project Upgrades.
IMXLUG v.L4.14.98_2.0.0_ga	04/2019	i.MX 4.14 Kernel upgrade and board updates.
IMXLUG v.L4.14.78_1.0.0_ga	01/2019	i.MX 6, i.MX 7, i.MX 8 family GA release.
IMXLUG v.L4.14.62_1.0.0_beta	11/2018	i.MX 4.14 Kernel Upgrade, Yocto Project Sumo upgrade.
IMXLUG v.L4.9.123_2.3.0_8mm	09/2018	i.MX 8M Mini GA release.
IMXLUG v.L4.9.88_2.2.0_8qxp-beta2	07/2018	i.MX 8QuadXPlus Beta2 release.

## Revision history...continued

Document ID	Release date	Description
IMXLUG v.L4.9.88_2.1.0_8mm-alpha	06/2018	i.MX 8M Mini Alpha release.
IMXLUG v.L4.9.88_2.0.0-ga	05/2018	i.MX 7ULP and i.MX 8M Quad GA release.
IMXLUG v.L4.9.51_imx8mq-ga	03/2018	Added i.MX 8M Quad GA.
IMXLUG v.L4.9.51_8qm-beta2/8qxp-beta	02/2018	Added i.MX 8QuadMax Beta2 and i.MX 8QuadXPlus Beta.
IMXLUG v.L4.9.51_imx8mq-beta	12/2017	Added i.MX 8M Quad.
IMXLUG v.L4.9.51_imx8qm-beta1	12/2017	Added i.MX 8QuadMax.
IMXLUG v.L4.9.51_imx8qxp-alpha	11/2017	Initial release.

## Legal information

### Definitions

**Draft** — A draft status on a document indicates that the content is still under internal review and subject to formal approval, which may result in modifications or additions. NXP Semiconductors does not give any representations or warranties as to the accuracy or completeness of information included in a draft version of a document and shall have no liability for the consequences of use of such information.

### Disclaimers

**Limited warranty and liability** — Information in this document is believed to be accurate and reliable. However, NXP Semiconductors does not give any representations or warranties, expressed or implied, as to the accuracy or completeness of such information and shall have no liability for the consequences of use of such information. NXP Semiconductors takes no responsibility for the content in this document if provided by an information source outside of NXP Semiconductors.

In no event shall NXP Semiconductors be liable for any indirect, incidental, punitive, special or consequential damages (including - without limitation - lost profits, lost savings, business interruption, costs related to the removal or replacement of any products or rework charges) whether or not such damages are based on tort (including negligence), warranty, breach of contract or any other legal theory.

Notwithstanding any damages that customer might incur for any reason whatsoever, NXP Semiconductors' aggregate and cumulative liability towards customer for the products described herein shall be limited in accordance with the Terms and conditions of commercial sale of NXP Semiconductors.

**Right to make changes** — NXP Semiconductors reserves the right to make changes to information published in this document, including without limitation specifications and product descriptions, at any time and without notice. This document supersedes and replaces all information supplied prior to the publication hereof.

**Suitability for use** — NXP Semiconductors products are not designed, authorized or warranted to be suitable for use in life support, life-critical or safety-critical systems or equipment, nor in applications where failure or malfunction of an NXP Semiconductors product can reasonably be expected to result in personal injury, death or severe property or environmental damage. NXP Semiconductors and its suppliers accept no liability for inclusion and/or use of NXP Semiconductors products in such equipment or applications and therefore such inclusion and/or use is at the customer's own risk.

**Applications** — Applications that are described herein for any of these products are for illustrative purposes only. NXP Semiconductors makes no representation or warranty that such applications will be suitable for the specified use without further testing or modification.

Customers are responsible for the design and operation of their applications and products using NXP Semiconductors products, and NXP Semiconductors accepts no liability for any assistance with applications or customer product design. It is customer's sole responsibility to determine whether the NXP Semiconductors product is suitable and fit for the customer's applications and products planned, as well as for the planned application and use of customer's third party customer(s). Customers should provide appropriate design and operating safeguards to minimize the risks associated with their applications and products.

NXP Semiconductors does not accept any liability related to any default, damage, costs or problem which is based on any weakness or default in the customer's applications or products, or the application or use by customer's third party customer(s). Customer is responsible for doing all necessary testing for the customer's applications and products using NXP Semiconductors products in order to avoid a default of the applications and the products or of the application or use by customer's third party customer(s). NXP does not accept any liability in this respect.

**Terms and conditions of commercial sale** — NXP Semiconductors products are sold subject to the general terms and conditions of commercial sale, as published at <https://www.nxp.com/profile/terms>, unless otherwise agreed in a valid written individual agreement. In case an individual agreement is concluded only the terms and conditions of the respective agreement shall apply. NXP Semiconductors hereby expressly objects to applying the customer's general terms and conditions with regard to the purchase of NXP Semiconductors products by customer.

**Export control** — This document as well as the item(s) described herein may be subject to export control regulations. Export might require a prior authorization from competent authorities.

**Suitability for use in non-automotive qualified products** — Unless this document expressly states that this specific NXP Semiconductors product is automotive qualified, the product is not suitable for automotive use. It is neither qualified nor tested in accordance with automotive testing or application requirements. NXP Semiconductors accepts no liability for inclusion and/or use of non-automotive qualified products in automotive equipment or applications.

In the event that customer uses the product for design-in and use in automotive applications to automotive specifications and standards, customer (a) shall use the product without NXP Semiconductors' warranty of the product for such automotive applications, use and specifications, and (b) whenever customer uses the product for automotive applications beyond NXP Semiconductors' specifications such use shall be solely at customer's own risk, and (c) customer fully indemnifies NXP Semiconductors for any liability, damages or failed product claims resulting from customer design and use of the product for automotive applications beyond NXP Semiconductors' standard warranty and NXP Semiconductors' product specifications.

**Translations** — A non-English (translated) version of a document, including the legal information in that document, is for reference only. The English version shall prevail in case of any discrepancy between the translated and English versions.

**Security** — Customer understands that all NXP products may be subject to unidentified vulnerabilities or may support established security standards or specifications with known limitations. Customer is responsible for the design and operation of its applications and products throughout their lifecycles to reduce the effect of these vulnerabilities on customer's applications and products. Customer's responsibility also extends to other open and/or proprietary technologies supported by NXP products for use in customer's applications. NXP accepts no liability for any vulnerability. Customer should regularly check security updates from NXP and follow up appropriately. Customer shall select products with security features that best meet rules, regulations, and standards of the intended application and make the ultimate design decisions regarding its products and is solely responsible for compliance with all legal, regulatory, and security related requirements concerning its products, regardless of any information or support that may be provided by NXP.

NXP has a Product Security Incident Response Team (PSIRT) (reachable at [PSIRT@nxp.com](mailto:PSIRT@nxp.com)) that manages the investigation, reporting, and solution release to security vulnerabilities of NXP products.

**NXP B.V.** — NXP B.V. is not an operating company and it does not distribute or sell products.

### Trademarks

Notice: All referenced brands, product names, service names, and trademarks are the property of their respective owners.

**NXP** — wordmark and logo are trademarks of NXP B.V.

**AMBA, Arm, Arm7, Arm7TDMI, Arm9, Arm11, Artisan, big.LITTLE, Cordio, CoreLink, CoreSight, Cortex, DesignStart, DynamIQ, Jazelle, Keil, Mali, Mbed, Mbed Enabled, NEON, POP, RealView, SecurCore, Socrates, Thumb, TrustZone, ULINK, ULINK2, ULINK-ME, ULINK-PLUS, ULINKpro,  $\mu$ Vision, Versatile** — are trademarks and/or registered trademarks of Arm Limited (or its subsidiaries or affiliates) in the US and/or elsewhere. The related technology may be protected by any or all of patents, copyrights, designs and trade secrets. All rights reserved.

**Bluetooth** — the Bluetooth wordmark and logos are registered trademarks owned by Bluetooth SIG, Inc. and any use of such marks by NXP Semiconductors is under license.

**EdgeLock** — is a trademark of NXP B.V.

**eIQ** — is a trademark of NXP B.V.

**Freescale** — is a trademark of NXP B.V.

**i.MX** — is a trademark of NXP B.V.

**Layerscape** — is a trademark of NXP B.V.

**PyTorch, the PyTorch logo and any related marks** — are trademarks of The Linux Foundation.

**TensorFlow, the TensorFlow logo and any related marks** — are trademarks of Google Inc.

Contents

<b>1</b>	<b>Overview</b>	<b>2</b>	4.7	Running Linux OS on the target	41
1.1	Audience	2	4.7.1	Running the image from NAND	43
1.2	Conventions	2	4.7.2	Running Linux OS from Parallel NOR	44
1.3	Supported hardware SoCs and boards	2	4.7.3	Running the Linux OS image from QuadSPI	44
1.4	References	3	4.7.4	Running the Arm Cortex-M4/7/33 image	44
<b>2</b>	<b>Introduction</b>	<b>4</b>	4.7.5	Linux OS login	47
<b>3</b>	<b>Basic Terminal Setup</b>	<b>5</b>	4.7.6	Running Linux OS from MMC/SD	47
<b>4</b>	<b>Booting Linux OS</b>	<b>5</b>	4.7.7	Running the Linux image from NFS	48
4.1	Software overview	5	4.8	Arm SystemReady-IR	48
4.1.1	Bootloader	6	4.8.1	Arm SystemReady-IR ACS compliance test	49
4.1.2	Linux kernel image and device tree	7	4.8.2	Capsule update	49
4.1.3	Root file system	7	4.8.3	Linux distro installation	49
4.2	Universal update utility	8	<b>5</b>	<b>Enabling Solo Emulation</b>	<b>50</b>
4.2.1	Downloading UUU	8	<b>6</b>	<b>Power Management</b>	<b>50</b>
4.2.2	Using UUU	8	6.1	Suspend and resume	50
4.3	Preparing an SD/MMC card to boot	9	6.2	CPU frequency scaling	51
4.3.1	Preparing the card	10	6.3	Bus frequency scaling	51
4.3.2	Copying the full SD card image	10	<b>7</b>	<b>Multimedia</b>	<b>52</b>
4.3.3	Partitioning the SD/MMC card	10	7.1	i.MX multimedia packages	52
4.3.4	Copying a bootloader image	11	7.2	Building limited access packages	53
4.3.5	Copying the kernel image and DTB file	11	7.3	Multimedia use cases	53
4.3.6	Copying the root file system (rootfs)	12	7.3.1	Playback use cases	53
4.4	Downloading images	13	7.3.1.1	Audio-only playback	53
4.4.1	Downloading images using U-Boot	13	7.3.1.2	Video-only playback	54
4.4.1.1	Flashing an Arm Cortex-M4 image on QuadSPI	13	7.3.1.3	Audio/Video file playback	54
4.4.1.2	Downloading an image to MMC/SD	14	7.3.1.4	Multichannel audio playback	54
4.4.1.3	Using eMMC	16	7.3.1.5	Other methods for playback	55
4.4.1.4	Flashing U-Boot on SPI-NOR from U-Boot	19	7.3.1.6	Video playback to multiple displays	55
4.4.1.5	Flashing U-Boot on Parallel NOR from U-Boot	20	7.3.2	Audio encoding	56
4.4.2	Using an i.MX board as the host server to create a rootfs	20	7.3.3	Video encoding	56
4.5	How to boot the i.MX boards	23	7.3.4	Transcoding	57
4.5.1	Booting from an SD card in slot SD1	23	7.3.5	Audio recording	58
4.5.2	Booting from an SD card in slot SD2	24	7.3.6	Video recording	59
4.5.3	Booting from an SD card in slot SD3	25	7.3.7	Audio/Video recording	60
4.5.4	Booting from an SD card in slot SD4	26	7.3.8	Camera preview	60
4.5.5	Booting from eMMC	26	7.3.9	Recording the TV-in source	60
4.5.6	Booting from SATA	28	7.3.10	Web camera	61
4.5.7	Booting from NAND	29	7.3.11	HTTP streaming	61
4.5.8	Booting from SPI-NOR	29	7.3.12	HTTP live streaming	61
4.5.9	Booting from EIM (Parallel) NOR	29	7.3.13	MPEG-DASH streaming	61
4.5.10	Booting from QuadSPI or FlexSPI	30	7.3.14	Real Time Streaming Protocol (RTSP) playback	62
4.5.11	Serial download mode for the Manufacturing Tool	31	7.3.15	RTP/UDP MPEGTS streaming	62
4.5.12	How to build U-Boot and Kernel in standalone environment	33	7.3.16	RTSP streaming server	63
4.5.13	How to build imx-boot image by using imx-mkimage	36	7.3.17	Video conversion	64
4.6	Flash memory maps	39	7.3.18	Video composition	65
4.6.1	MMC/SD/SATA memory map	40	7.4	PipeWire input/output settings	66
4.6.2	NAND flash memory map	40	7.4.1	PipeWire settings	66
4.6.3	Parallel NOR flash memory map	40	7.5	Installing gstreamer1.0-libav into rootfs	67
4.6.4	SPI-NOR flash memory map	40	<b>8</b>	<b>Audio</b>	<b>68</b>
4.6.5	QuadSPI flash memory map	41	8.1	DSP support	68
			8.1.1	HiFi 4 DSP framework	68
			8.1.2	Sound Open Firmware	68
			8.2	HDMI eARC support	68
			8.3	Low power voice UI	69
			8.3.1	Introduction	69

8.3.2	Standard voice solution	70	10.6.1	Prerequisites	103
8.3.3	Audio Front End (AFE)	71	10.6.2	Building the kernel	103
8.3.4	Linux drivers	75	10.6.2.1	Kernel configuration	103
8.3.5	Cortex-M Image	75	10.6.2.2	Building a toolchain	103
8.3.5.1	Application name	75	10.6.2.3	Cross compiling the user space sources	103
8.3.5.2	Board setup	75	10.6.3	Usage	104
8.3.5.3	Execution	76	10.6.4	Use case example	104
8.3.6	Power consumption notes	77	10.7	Kernel TLS offload	105
8.3.7	Using Linux remoteproc (i.MX 93 only)	77	10.7.1	Prerequisites	105
8.4	Conversa Integration	77	10.7.2	Running Kernel TLS test	105
<b>9</b>	<b>Graphics</b>	<b>78</b>	10.8	IMA/EVM on i.MX SoCs	105
9.1	imx-gpu-sdk	79	10.8.1	EVM Key on user keyrings	106
9.2	G2D-imx-samples	79	10.8.2	Modes of operation in IMA EVM	106
9.3	viv_samples	79	10.8.3	Build Steps	106
9.4	Qt 6	80	10.8.4	Steps to verify IMA EVM feature	107
<b>10</b>	<b>Security</b>	<b>80</b>	10.9	Security reference design	108
10.1	CAAM kernel driver	80	10.9.1	Automated image signing for secure boot	108
10.1.1	Introduction	80	10.9.1.1	NXP CST Signer	108
10.1.2	Source files	81	10.9.1.2	Prerequisites for preparing a signed image	108
10.1.3	Module loading	82	10.9.1.3	Yocto setup for secure boot build	109
10.1.4	Kernel configuration	82	10.9.1.4	Generating a signed bootloader/kernel/WIC image in Yocto project	109
10.1.5	How to test the drivers	83	10.9.1.5	Bootting a signed image	109
10.2	Crypto algorithms support	85	<b>11</b>	<b>Connectivity</b>	<b>110</b>
10.3	CAAM Job Ring backend driver specifications	86	11.1	Connectivity for Bluetooth wireless technology and Wi-Fi	110
10.3.1	Verifying driver operation and correctness	87	11.2	Connectivity for USB type-C	112
10.3.2	Incrementing IRQs in /proc/interrupts	87	11.3	NXP Bluetooth/Wi-Fi information	113
10.3.3	Verifying the 'self test' fields say 'passed' in /proc/crypto	87	11.4	Hardware limitations	114
10.4	OpenSSL offload	88	11.5	Certification	114
10.4.1	OpenSSL software architecture	88	11.5.1	WFA certification	115
10.4.2	OpenSSL's ENGINE interface	89	11.5.2	Bluetooth controller certification	115
10.4.3	NXP solution for OpenSSL hardware offloading	89	<b>12</b>	<b>DDR Performance Monitor</b>	<b>115</b>
10.4.4	Deploying OpenSSL into rootfs	90	12.1	Introduction	115
10.4.5	Running OpenSSL benchmarking tests with cryptodev engine	90	12.2	Frequently used events	115
10.4.5.1	Running OpenSSL benchmarking tests for symmetric ciphering and digest	90	12.3	Showing supported events	115
10.4.6	Running OpenSSL benchmarking tests with AF_ALG engine	91	12.4	Examples for monitoring transactions	116
10.4.6.1	Running OpenSSL benchmarking tests for symmetric ciphering and digest	91	12.5	Performance metric	117
10.4.7	Running OpenSSL asymmetric tests with PKCS#11 based engine	91	12.5.1	Showing supported metric	117
10.4.7.1	Running p11tool to generate key (RSA or EC)	92	12.5.2	Monitoring transactions	117
10.4.7.2	Using OpenSSL from command line	93	12.6	DDR Performance usage summary	117
10.4.7.3	Running OpenSSL test for RSA	93	<b>13</b>	<b>One-Time Programmable Controller Driver Using NVMEM Subsystem</b>	<b>117</b>
10.4.7.4	Running OpenSSL test for EC	93	13.1	Introduction	118
10.5	Disk encryption acceleration	94	13.2	NVMEM provider OCOTP	118
10.5.1	Enabling disk encryption support in kernel	94	13.3	NVMEM consumer	118
10.5.2	User space tools for disk encryption	95	13.4	Examples to read/write the raw NVMEM file in user space	118
10.5.3	DM-Crypt using CAAM backed keys	95	<b>14</b>	<b>NXP eIQ Machine Learning</b>	<b>119</b>
10.5.3.1	DM-Crypt with Trusted keys backed by CAAM	96	<b>15</b>	<b>Murata Wi-Fi/Bluetooth Solutions</b>	<b>119</b>
10.5.3.2	DM-Crypt with CAAM's tagged key	98	<b>16</b>	<b>Note About the Source Code in the Document</b>	<b>121</b>
10.5.4	Usage	100	<b>17</b>	<b>Revision History</b>	<b>121</b>
10.6	crypto_af_alg application support	103		<b>Legal information</b>	<b>124</b>

Please be aware that important notices concerning this document and the product(s) described herein, have been included in section 'Legal information'.

© 2024 NXP B.V.

All rights reserved.

For more information, please visit: <https://www.nxp.com>

Date of release: 29 March 2024  
Document identifier: IMXLUG