

Not Recommended for New Designs.
Use MC1320x.

MC13192

2.4 GHz Low Power Transceiver
for the IEEE® 802.15.4 Standard

Reference Manual

Document Number: MC13192RM
Rev. 1.6
04/2008

Not Recommended for Design
Use MC1320X

How to Reach Us:

Home Page:
www.freescale.com

E-mail:
support@freescale.com

USA/Europe or Locations Not Listed:
Freescale Semiconductor
Technical Information Center, CH370
1300 N. Alma School Road
Chandler, Arizona 85224
+1-800-521-6274 or +1-480-768-2130
support@freescale.com

Europe, Middle East, and Africa:
Freescale Halbleiter Deutschland GmbH
Technical Information Center
Schatzbogen 7
81829 Muenchen, Germany
+44 1296 380 456 (English)
+46 8 52200080 (English)
+49 89 92103 559 (German)
+33 1 69 35 48 48 (French)
support@freescale.com

Japan:
Freescale Semiconductor Japan Ltd.
Headquarters
ARCO Tower 15F
1-8-1, Shimo-Meguro, Meguro-ku,
Tokyo 153-0064, Japan
0120 191014 or +81 3 5437 9125
support.japan@freescale.com

Asia/Pacific:
Freescale Semiconductor Hong Kong Ltd.
Technical Information Center
2 Dai King Street
Tai Po Industrial Estate
Tai Po, N.T., Hong Kong
+800 2666 8080
support.asia@freescale.com

For Literature Requests Only:
Freescale Semiconductor Literature Distribution Center
P.O. Box 5405
Denver, Colorado 80217
1-800-521-6274 or 303-675-2140
Fax: 303-675-2150
LDCForFreescaleSemiconductor@hibbertgroup.com

Information in this document is provided solely to enable system and software implementers to use Freescale Semiconductor products. There are no express or implied copyright licenses granted hereunder to design or fabricate any integrated circuits or integrated circuits based on the information in this document.

Freescale Semiconductor reserves the right to make changes without further notice to any products herein. Freescale Semiconductor makes no warranty, representation or guarantee regarding the suitability of its products for any particular purpose, nor does Freescale Semiconductor assume any liability arising out of the application or use of any product or circuit, and specifically disclaims any and all liability, including without limitation consequential or incidental damages. "Typical" parameters that may be provided in Freescale Semiconductor data sheets and/or specifications can and do vary in different applications and actual performance may vary over time. All operating parameters, including "Typicals", must be validated for each customer application by customer's technical experts. Freescale Semiconductor does not convey any license under its patent rights nor the rights of others. Freescale Semiconductor products are not designed, intended, or authorized for use as components in systems intended for surgical implant into the body, or other applications intended to support or sustain life, or for any other application in which the failure of the Freescale Semiconductor product could create a situation where personal injury or death may occur. Should Buyer purchase or use Freescale Semiconductor products for any such unintended or unauthorized application, Buyer shall indemnify and hold Freescale Semiconductor and its officers, employees, subsidiaries, affiliates, and distributors harmless against all claims, costs, damages, and expenses, and reasonable attorney fees arising out of, directly or indirectly, any claim of personal injury or death associated with such unintended or unauthorized use, even if such claim alleges that Freescale Semiconductor was negligent regarding the design or manufacture of the part.

Freescale™ and the Freescale logo are trademarks of Freescale Semiconductor, Inc. All other product or service names are the property of their respective owners.

© Freescale Semiconductor, Inc. 2005, 2006, 2007, 2008. All rights reserved.

Contents

About This Book

Audience	ix
Organization	ix
Revision History	x
Conventions	x
Definitions, Acronyms, and Abbreviations	x
References	xi

Chapter 1 Introduction

1.1	Features	1-2
1.2	Software Support	1-2
1.2.1	Simple MAC (SMAC)	1-3
1.2.2	802.15.4 Standard-Compliant MAC	1-3
1.2.3	ZigBee-Compliant Network Stack (BeeStack)	1-3
1.3	Block Diagrams	1-3
1.4	Data Transfer Modes	1-4
1.5	Packet Structure	1-4
1.6	Receive Path Description	1-5
1.7	Transmit Path Description	1-5

Chapter 2 MC13192 Pins and Connections

2.1	Device Pin Assignment	2-1
2.2	Pin Definitions	2-2

Chapter 3 System Considerations

3.1	Introduction	3-1
3.2	Power Connections	3-1
3.3	Test Pin SM	3-2
3.4	Reset Usage	3-2
3.5	MC13192 Interface to MCU	3-3
3.5.1	SPI Command Channel	3-3
3.5.2	Interrupt Request to MCU	3-4
3.5.3	Modem Control Signals	3-4
3.5.4	Modem Status Signals	3-4
3.6	System Oscillator and Clock Considerations	3-4
3.6.1	Modem Crystal Oscillator	3-4
3.6.2	System Clock Configurations	3-5
3.6.3	Single System Crystal with CLK0 driving MCU crystal input	3-6
3.7	GPIO Characteristics	3-6

3.8	MC13192 Digital Signal Properties Summary	3-7
3.9	Transceiver RF Port Operation and External Connections	3-8
3.10	Low Power Considerations	3-9
3.10.1	Modem Low Power States	3-10
3.10.2	Special Considerations for Hibernate and Doze Low Power Modes	3-11
3.10.2.1	Doze Current Higher Than Specified	3-11
3.10.2.2	Asserting ATTN Early to Exit Hibernate or Doze Mode	3-11
3.10.3	Recovery Times from Low Power Modes	3-12
3.10.3.1	Modem Active Currents	3-13
3.10.3.1.1	Modem CCA/ED Timing profile	3-13
3.10.3.1.2	Modem RX Timing profile	3-14
3.10.3.1.3	Modem TX Timing profile	3-14
3.10.4	General System Considerations for Low Power	3-15

Chapter 4 SPI Register Descriptions

4.1	Overview	4-1
4.2	Mandatory Register Initialization	4-1
4.3	Register Model and Description Details	4-2
4.4	Reset - Register 00	4-5
4.5	RX_Pkt_RAM - Register 01	4-5
4.6	TX_Pkt_RAM - Register 02	4-6
4.7	TX_Pkt_Ctl - Register 03	4-7
4.8	CCA_Thresh - Register 04	4-8
4.9	IRQ_Mask - Register 05	4-9
4.10	Control_A - Register 06	4-11
4.11	Control_B - Register 07	4-13
4.12	PA_Enable - Register 08	4-14
4.13	Control_C - Register 09	4-15
4.14	CLKO_Ctl - Register 0A	4-16
4.15	GPIO_Dir - Register 0B	4-17
4.16	GPIO_Data_Out - Register 0C	4-19
4.17	LO1_Int_Div - Register 0F	4-20
4.18	LO1_Num - Register 10	4-21
4.19	PA_Lvl - Register 12	4-22
4.20	Tmr_Cmp1_A - Register 1B	4-23
4.21	Tmr_Cmp1_B - Register 1C	4-23
4.22	Tmr_Cmp2_A - Register 1D	4-25
4.23	Tmr_Cmp2_B - Register 1E	4-25
4.24	Tmr_Cmp3_A - Register 1F	4-27
4.25	Tmr_Cmp3_B - Register 20	4-27
4.26	Tmr_Cmp4_A - Register 21	4-29
4.27	Tmr_Cmp4_B - Register 22	4-30
4.28	TC2_Prime - Register 23	4-31

4.29	IRQ_Status - Register 24	4-32
4.30	RST_Ind - Register 25	4-34
4.31	Current_Time_A - Register 26	4-35
4.32	Current_Time_B - Register 27	4-35
4.33	GPIO_Data_In - Register 28	4-36
4.34	Chip_ID - Register 2C	4-37
4.35	RX_Status - Register 2D	4-37
4.36	Timestamp_A - Register 2E	4-38
4.37	Timestamp_B - Register 2F	4-38
4.38	BER_Enable - Register 30	4-39
4.39	PSM_Mode - Register 31	4-40

Chapter 5 Serial Peripheral Interface (SPI)

5.1	Overview	5-1
5.2	SPI Basic Operation	5-1
5.2.1	SPI Pin Definition	5-1
5.2.1.1	Chip Enable (CE)	5-2
5.2.1.2	SPI Clock (SPICLK)	5-2
5.2.1.3	Master Out / Slave In (MOSI)	5-2
5.2.1.4	Master In / Slave Out (MISO)	5-2
5.2.1.4.1	Setting MISO Output Drive Strength	5-2
5.2.1.4.2	Setting MISO Off Impedance	5-2
5.2.2	SPI Burst Operation	5-3
5.3	SPI Singular Transactions	5-3
5.3.1	SPI Singular Transaction Signalling	5-4
5.3.2	SPI Singular Transaction Protocol	5-4
5.4	Symbol / Data Format	5-5
5.5	SPI Recursive Transactions	5-6
5.5.1	Recursive SPI Register Read	5-6
5.5.2	Recursive SPI Register Write	5-6
5.5.3	Special Case - Packet RAM Access	5-7
5.5.3.1	Recursive Receive Packet RAM Read Access	5-7
5.5.3.1.1	Receive Packet RAM Read Access Flow	5-7
5.5.3.1.2	Receive Packet RAM Read Access Error Conditions	5-8
5.5.3.2	Recursive Transmit Packet RAM Write Access	5-8
5.5.3.2.1	Transmit Packet RAM Write Access Flow	5-9
5.5.3.2.2	Transmit Packet RAM Write Access Error Conditions	5-9
5.6	Program Reset (Writing Address 0x00)	5-10

Chapter 6 Modes of Operation

6.1	Operational Modes Summary	6-1
6.2	Low Power Modes	6-4

6.2.1	Off Mode	6-4
6.2.2	Hibernate Mode	6-4
6.2.3	Doze Mode	6-4
6.2.3.1	Normal Doze Mode	6-4
6.2.3.2	Acoma Doze Mode	6-5
6.3	Active Modes	6-5
6.3.1	Idle Mode	6-5
6.3.2	Controlling Transition to Other Active Modes from Idle	6-6
6.3.3	Packet Mode Data Transfer TX and RX Operation	6-6
6.3.3.1	Packet Receive Mode	6-7
6.3.3.2	Aborting a Packet Receive Sequence	6-8
6.3.3.3	Packet Transmit Mode	6-8
6.3.4	Stream Mode Data Transfer TX and RX Operation	6-9
6.3.4.1	Stream Receive Mode	6-11
6.3.4.2	Aborting a Stream Receive Mode Sequence	6-12
6.3.4.3	Stream Transmit Mode	6-13
6.3.5	Clear Channel Assessment (CCA) Modes (including Link Quality Indication)	6-14
6.3.5.1	Clear Channel Assessment Function (use_strm is zero)	6-14
6.3.5.2	Energy Detect Function (use_strm is zero)	6-17
6.3.5.3	CCA / ED While in Stream Mode (use_strm is one)	6-18
6.3.5.4	Link Quality Indication	6-18
6.4	Frequency of Operation	6-18
6.5	Transmit Power Adjustment	6-19
6.6	2.4GHz PLL Out-of-Lock Interrupt	6-20

Chapter 7 Timer Information

7.1	Event Timer Block	7-1
7.2	Event Timer Time Base	7-2
7.3	Setting Current Time	7-2
7.4	Reading Current Time	7-3
7.5	Latching the Timestamp	7-3
7.6	Event Timer Comparators	7-3
7.6.1	Timer Compare Fields	7-3
7.6.2	Timer Disable Bits	7-4
7.6.3	Timer Status Flags	7-4
7.6.4	Timer Interrupt Masks	7-4
7.6.5	Setting Compare Values	7-5
7.7	Intended Event Timer Usage	7-5
7.7.1	Generating Time-Based Interrupts	7-5
7.7.2	Using tmr_cmp2[23:0] to Exit Doze Mode	7-6
7.7.3	Timer-Triggered Transceiver Events	7-6
7.7.3.1	Packet Mode Timer_Triggered TX or RX Events	7-7
7.7.3.2	Stream Mode Timer_Triggered TX or RX Events	7-7

Chapter 8 Interrupt Description

8.1	Interrupts	8-1
8.1.1	Interrupt Sources	8-2
8.1.2	Output Pin IRQ	8-3
8.1.2.1	Programming IRQ Pullup	8-3
8.1.2.2	Setting IRQ Output Drive Strength	8-3
8.2	PLL_lock_irq Status Bit and Operation	8-4
8.3	Attn_irq Status Bit and Interrupt Operation	8-4
8.4	Interrupts from Exiting Low Power Modes	8-4
8.4.1	Exiting Off Mode (Reset)	8-4
8.4.2	Exiting Hibernate Mode	8-5
8.4.3	Exiting Doze Mode(s)	8-5

Chapter 9 Miscellaneous Functions

9.1	Reset Function	9-1
9.1.1	Input Pin RST	9-1
9.1.2	Software Reset (Writing to Register 00)	9-1
9.1.3	Reset Indicator Bit (RST_Ind Register 25, Bit 7)	9-1
9.2	General Purpose Input/Output	9-2
9.2.1	Configuring GPIO Direction	9-2
9.2.2	Setting GPIO Output Drive Strength	9-2
9.2.3	Programming GPIO Output Value	9-2
9.2.4	Reading GPIO Input State	9-3
9.2.5	GPIO1 and GPIO2 as Status Indicators	9-3
9.3	Crystal Oscillator	9-3
9.3.1	Crystal Requirements	9-4
9.3.2	Crystal Trim Operation	9-4
9.4	Output Clock Pin CLKO	9-5
9.4.1	Enable CLKO (clko_en, Control_C Register 09, Bit 5)	9-5
9.4.2	Setting CLKO frequency (clko_rate[2:0], CLKO_Ctl Register 0A, Bits 2-0)	9-5
9.4.3	Enable CLKO During Doze Mode (clko_doze_en, Control_B Register 07, Bit 9)	9-5
9.4.4	Setting CLKO Output Drive Strength (clko_drv[1:0], GPIO_Data_Out Register 0C, Bits 11-10)	9-6
9.5	Input Pin ATTN	9-6

Not Recommended for New Designs.
Use MC1320X.

About This Book

This manual describes the Freescale MC13192. The MC13192 is a 2.4 GHz ISM band transceiver built for the 802.15.4 Standard. The MC13192 transceiver can function as a standalone transceiver or when combined with a software package and an HCS08 MCU, they form the Freescale 802.15.4 Standard platform solution.

Audience

This manual is intended for system designers.

Organization

This document is organized into nine (9) chapters.

- Chapter 1 **Introduction** — The MC13192 is Freescale’s ZigBee™ transceiver. This transceiver is a low power, 2.4 GHz radio frequency transceiver that can be coupled with an 8-bit microcontroller.
- Chapter 2 **Pins and Connections** — Describes device pinout and functionality.
- Chapter 3 **System Considerations** — Describes system level considerations of the MC13192 modem.
- Chapter 4 **SPI Register Descriptions** — Details how all control, reading of status, writing of data, and reading of data is done through the MC13192 SPI port.
- Chapter 5 **SPI** — Shows how the MC13192 modem and CPU communicate primarily through the onboard SPI command channel.
- Chapter 6 **Modes of Operation** — Describes the numerous MC13192 passive operational modes that allow for low-current operation as well as modes where the transceiver is active.
- Chapter 7 **Timer Information** — Describes how the MC13192 uses its internal Event Timer block to manage system timing.
- Chapter 8 **Interrupt Description** — Shows how interrupts provide a way for the MC13192 to inform the host microcontroller (MCU) of onboard events without requiring the MCU to constantly query MC13192 status.
- Chapter 9 **Miscellaneous Functions** — Describes how the MC13192 can be placed in one of two reset conditions either through hardware input M_RSTB or by writing to Reset Register 00.

Revision History

The following table summarizes revisions to this document since the previous release (Rev 1.5).

Revision History

Location	Revision
Entire document	Updated various specification numbers, fixed numerous stale cross references and updated for most recent software updates.

Conventions

This document uses the following notational conventions:

- Courier monospaced type indicate commands, command parameters, code examples, expressions, datatypes, and directives.
- Italic type indicates replaceable command parameters.
- All source code examples are in C.

Definitions, Acronyms, and Abbreviations

The following list defines the acronyms and abbreviations used in this document.

ACK	Acknowledgement Frame
API	Application Programming Interface
BB	Baseband
CCA	Clear Channel Assessment
CRC	Cyclical Redundancy Check
DCD	Differential Chip Decoding
DME	Device Management Entity
FCS	Frame Check Sequence
FFD	Full Function Device
FFD-C	Full Function Device Coordinator
FLI	Frame Length Indicator
GTS	Guaranteed Time Slot
HW	Hardware
IRQ	Interrupt Request
ISR	Interrupt Service Routine
LO	Local Oscillator
MAC	Medium Access Control
MCPS	MAC Common Part Sublayer
MCU	Microcontroller Unit
MLME	MAC Sublayer Management Entity

MSDU	MAC Service Data Unit
NWK	Network
PA	Power Amplifier
PAN	Personal Area Network
PANID	PAN Identification
PHY	PHYSical Layer
PIB	PAN Information Base
PPDU	PHY Protocol Data Unit
PSDU	PHY Service Data Unit
RF	Radio Frequency
RFD	Reduced Function Device
SAP	Service Access Point
SFD	Start of Frame Delimiter
SPI	Serial Peripheral Interface
SSCS	Service Specific Convergence Layer
SW	Software
VCO	Voltage Controlled Oscillator

References

The following sources were referenced to produce this book:

- [1] IEEE[®] 802.15.4 Standard
- [2] Freescale MC13192 Data Sheet

Not Recommended for New Designs.
Use MC1320X.

Chapter 1

Introduction

The MC13192 is a short range, low power, 2.4 GHz Industrial, Scientific, and Medical (ISM) band transceivers. The MC13192 contain a complete 802.15.4 Standard physical layer (PHY) modem designed for the 802.15.4 Standard which supports peer-to-peer, star, and mesh networking.

The MC13192 includes the 802.15.4 PHY/MAC for use with the HCS08 Family of MCUs.

When combined with an appropriate microcontroller (MCU), the MC13192 provides a cost-effective solution for short-range data links and networks. Interface with the MCU is accomplished using a four wire Serial Peripheral Interface (SPI) connection and an interrupt request output which allows for the use of a variety of processors. The software and processor can be scaled to fit applications ranging from simple point-to-point systems, through complete ZigBee networking.

Applications include, but are not limited to, the following:

- Residential and commercial automation
 - Lighting control
 - Security
 - Access control
 - Heating, ventilation, air-conditioning (HVAC)
 - Automated meter reading
- Industrial Control
 - Asset tracking and monitoring
 - Homeland security
 - Process management
 - Environmental monitoring and control
 - HVAC
 - Automated meter reading (AMR)
- Health Care
 - Patient monitoring
 - Fitness monitoring

The transceiver includes a low noise amplifier, 1.0 mW PA, VCO, onboard power supply regulation, full spread-spectrum encoding and decoding. The device supports 250 kbps Offset-Quadrature Phase Shift Keying (O-QPSK) data in 2.0 MHz channels with 5.0 MHz channel spacing per the 802.15.4 Standard. The SPI port and interrupt request output are used for receive (RX) and transmit (TX) data transfer and control.

1.1 Features

- Power supply range: 2.0 to 3.4 V
- Operates on one of 16 selectable channels in the 2.4 GHz ISM band
- 0 dBm nominal, programmable from -27 dBm up to 4 dBm typical maximum output power
- Buffered transmit and receive data packets for simplified use with low cost MCUs
- Supports both Packet Mode and Streaming Mode
- Supports 250 kbps O-QPSK data in 5.0 MHz channels and full spread-spectrum encode and decode (compatible with 802.15.4 Standard)
- Three power down modes for power conservation:
 - < 1 μ A Off current
 - 1 μ A Typical Hibernate current
 - 35 μ A Typical Doze current
- RX sensitivity of <-92 dBm (typical) at 1.0% packet error rate, much better than the 802.15.4 Standard of -85 dBm
- Four internal timer comparators available to reduce MCU resource requirements
- Programmable frequency clock output for use by MCU
- Onboard trim capability for 16 MHz crystal reference oscillator eliminates the need for external variable capacitors and allows for automated production frequency calibration.
- Seven general purpose input/output (GPIO) signals
- Operating temperature range: -40°C to 85°C
- Small form factor QFN-32 Package
 - RoHS compliant
 - Meets moisture sensitivity level (MSL) 3
 - 260°C peak reflow temperature
 - Meets lead-free requirements

1.2 Software Support

Freescale provides a wide range of software functionality to complement the MC13192 hardware. There are three levels of application solutions:

- Simple proprietary wireless connectivity
- User networks built on the 802.15.4 MAC
- ZigBee-compliant network stack (BeeStack)

1.2.1 Simple MAC (SMAC)

- Small memory footprint (about 3 kbytes typical)
- Supports point-to-point and star network configurations
- Proprietary networks
- Source code and application examples provided

1.2.2 802.15.4 Standard-Compliant MAC

- Supports star, mesh and cluster tree topologies
- Supports beacons networks
- Supports GTS for low latency
- Multiple power saving modes (idle, doze, hibernate)

1.2.3 ZigBee-Compliant Network Stack (BeeStack)

- Supports ZigBee 1.0 specification
- Supports star, mesh and tree networks
- Advanced Encryption Standard (AES) 128-bit security

1.3 Block Diagrams

Figure 1-1 shows a simplified block diagram of the MC13192 which is an 802.15.4 Standard compatible transceiver that provides the functions required in the physical layer (PHY) specification.

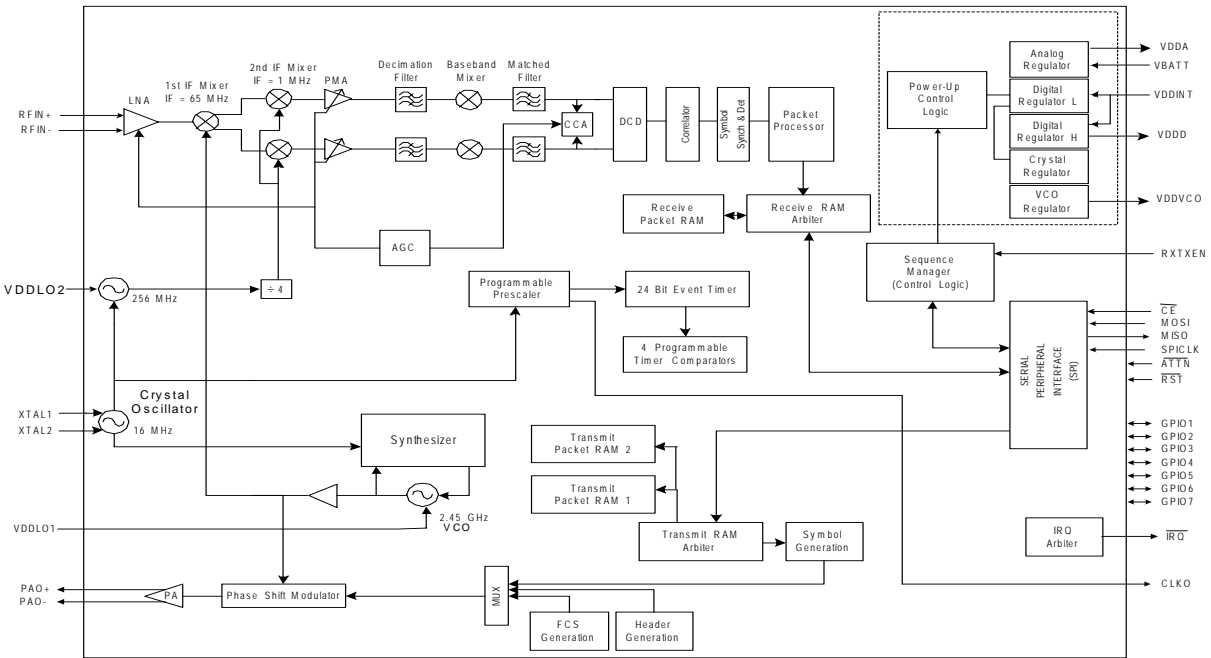

Figure 1-1. MC13192 Simplified Block Diagram

Figure 1-2 shows the basic system block diagram for the MC13192 in an application. Interface with the transceiver is accomplished through a 4-wire SPI port and interrupt request line. The media access control (MAC), drivers, and network and application software (as required) reside on the host processor. The host can vary from a simple 8-bit device up to a sophisticated 32-bit processor depending on application requirements.

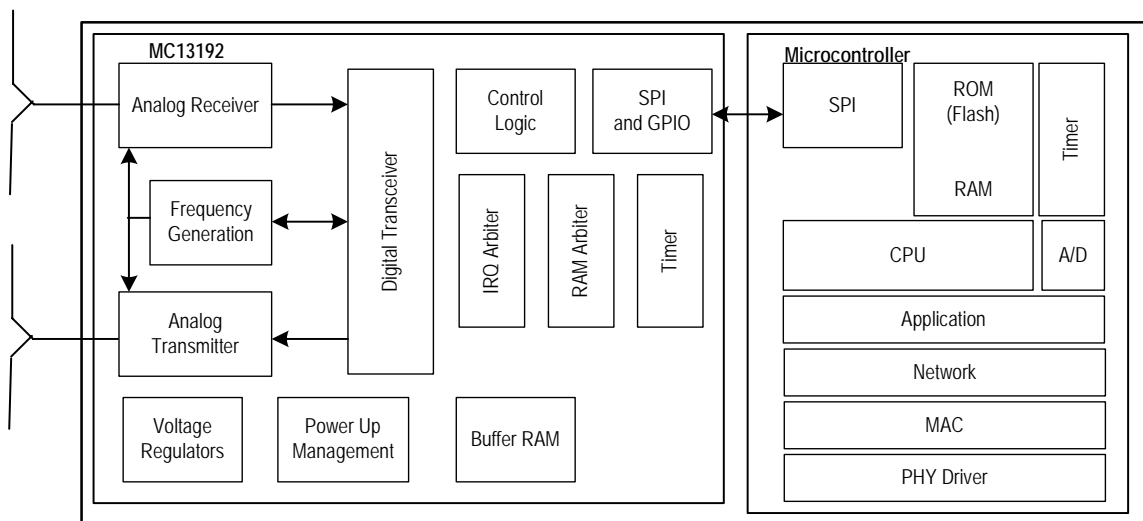

Figure 1-2. System Level Block Diagram

1.4 Data Transfer Modes

The MC13192 has two data transfer modes:

1. Packet Mode — Data is buffered in on-chip RAM.
2. Streaming Mode — Data is processed word-by-word.

The Freescale 802.15.4 MAC software only supports the streaming mode of data transfer. For proprietary applications, Packet Mode can be used to conserve MCU resources.

1.5 Packet Structure

Figure 1-3 shows the packet structure of the MC13192. Payloads of up to 125 bytes are supported. The MC13192 adds a four-byte preamble, a one-byte Start of Frame Delimiter (SFD), and a one-byte Frame Length Indicator (FLI) before the data. A Frame Check Sequence (FCS) is calculated and appended to the end of the data.

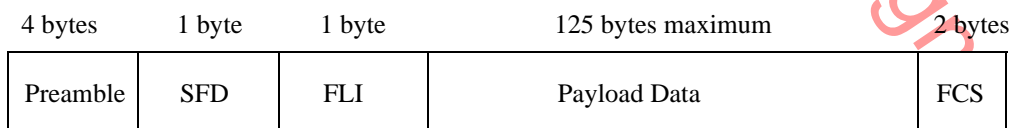

Figure 1-3. MC13192 Packet Structure

1.6 Receive Path Description

In the receive signal path, the RF input is converted to low IF In-phase and Quadrature (I & Q) signals through two down-conversion stages. A Clear Channel Assessment (CCA) can be performed based upon the baseband energy integrated over a specific time interval. The digital back end performs Differential Chip Detection (DCD), the correlator “de-spreads” the Direct Sequence Spread Spectrum (DSSS) Offset QPSK (O-QPSK) signal, determines the symbols and packets, and detects the data.

The preamble, SFD, and FLI are parsed and used to detect the payload data and FCS which are stored in RAM. A two-byte FCS is calculated on the received data and compared to the FCS value appended to the transmitted data, generating a Cyclical Redundancy Check (CRC) result. Link Quality is measured over a 64 μ s period after the packet preamble and stored in RAM.

If the MC13192 is in Packet Mode, the data is processed as an entire packet. The MCU is notified that an entire packet has been received via an interrupt.

If the MC13192 is in streaming mode, the MCU is notified by an interrupt on a word-by-word basis.

1.7 Transmit Path Description

For the transmit path, the TX data that was previously stored in RAM are retrieved (Packet Mode) or the TX data is clocked in via the SPI (Stream Mode), formed into packets per the 802.15.4 PHY, spread, and then up converted to the transmit frequency.

If the MC13192 is in Packet Mode, data is processed as an entire packet. The data is first loaded into the TX buffer. The MCU then requests that the MC13192 transmit the data. The MCU is notified via an interrupt when the whole packet has successfully been transmitted.

In streaming mode, the data is fed to the MC13192 on a word-by-word basis with an interrupt serving as a notification that the MC13192 is ready for more data. This continues until the whole packet is transmitted.

Not Recommended for New Designs.
Use MC1320X.

Chapter 2

MC13192 Pins and Connections

2.1 Device Pin Assignment

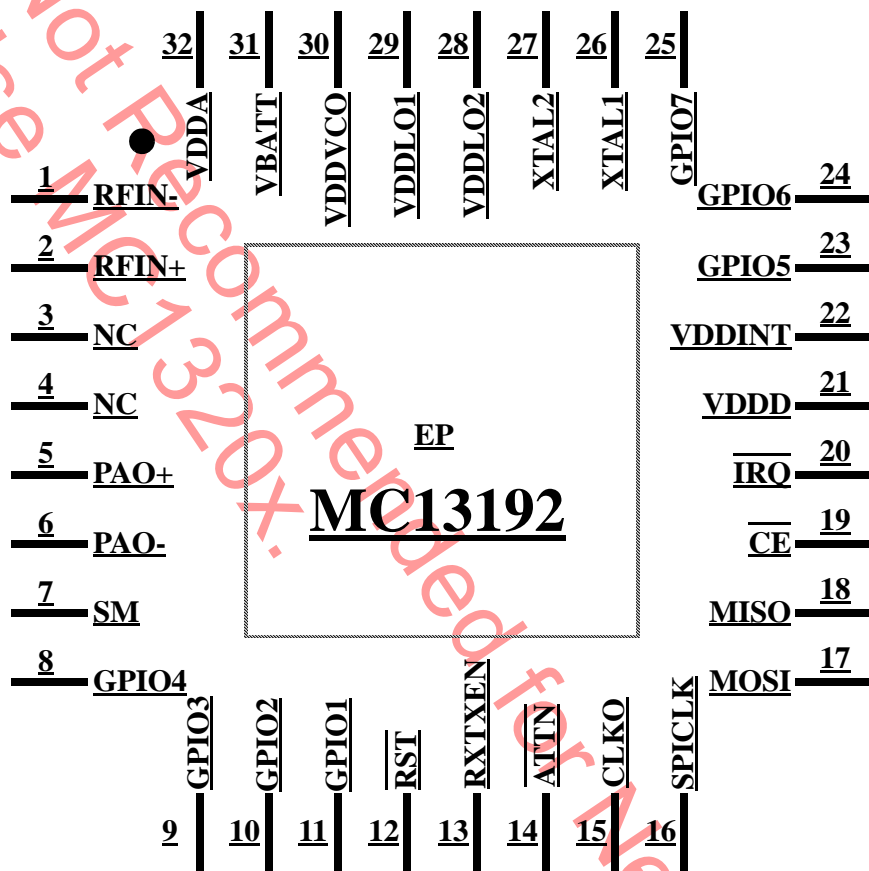

Figure 2-1. MC13192 Pinout

2.2 Pin Definitions

Table 2-1. Pin Function Description

Pin #	Pin Name	Type	Description	Functionality
1	RFIN-	RF Input	LNA negative differential input.	
2	RFIN+	RF Input	LNA positive differential input.	
3	Not Used		Tie to Ground.	
4	Not Used		Tie to Ground.	
5	PAO+	RF Output /DC Input	Power Amplifier Positive Output. Open drain. Connect to V_{DDA} .	
6	PAO-	RF Output/DC Input	Power Amplifier Negative Output. Open drain. Connect to V_{DDA} .	
7	SM		Test mode pin. Tie to Ground	Tie to Ground for normal operation
8	GPIO4	Digital Input/ Output	General Purpose Input/Output 4.	
9	GPIO3	Digital Input/ Output	General Purpose Input/Output 3.	
10	GPIO2	Digital Input/ Output	General Purpose Input/Output 2. When <code>gpio_alt_en</code> , Register 9, Bit 7 = 1, GPIO2 functions as a “CRC Valid” indicator.	
11	GPIO1	Digital Input/ Output	General Purpose Input/Output 1. When <code>gpio_alt_en</code> , Register 9, Bit 7 = 1, GPIO1 functions as an “Out of Idle” indicator.	
12	$\overline{\text{RST}}$	Digital Input	Active Low Reset. While held low, the IC is in Off Mode and all internal information is lost from RAM and SPI registers. When high, IC goes to IDLE Mode, with SPI in default state.	
13	RXTXEN	Digital Input	Active High. Low to high transition initiates RX or TX sequence depending on SPI setting. Should be taken high after SPI programming to start RX or TX sequence and should be held high through the sequence. After sequence is complete, return RXTXEN to low. When held low, forces Idle Mode.	
14	$\overline{\text{ATTN}}$	Digital Input	Active Low Attention. Transitions IC from either Hibernate or Doze Modes to Idle.	

Table 2-1. Pin Function Description (continued)

Pin #	Pin Name	Type	Description	Functionality
15	CLKO	Digital Output	Clock output to host MCU. Programmable frequencies of: 16 MHz, 8 MHz, 4 MHz, 2 MHz, 1 MHz, 62.5 kHz, 32.786+ kHz (default), and 16.393+ kHz.	
16	SPICLK	Digital Clock Input	External clock input for the SPI interface.	
17	MOSI	Digital Input	Master Out/Slave In. Dedicated SPI data input.	
18	MISO	Digital Output	Master In/Slave Out. Dedicated SPI data output.	
19	\overline{CE}	Digital Input	Active Low Chip Enable. Enables SPI transfers.	
20	\overline{IRQ}	Digital Output	Active Low Interrupt Request.	Open drain device. Programmable 40 k Ω internal pull-up. Interrupt can be serviced every 6 μ s with <20 pF load. Optional external pull-up must be >4 k Ω .
21	VDDD	Power Output	Digital regulated supply bypass.	Decouple to ground.
22	VDDINT	Power Input	Digital interface supply & digital regulator input. Connect to Battery.	2.0 to 3.4 V. Decouple to ground.
23	GPIO5	Digital Input/Output	General Purpose Input/Output 5.	
24	GPIO6	Digital Input/Output	General Purpose Input/Output 6.	
25	GPIO7	Digital Input/Output	General Purpose Input/Output 7.	
26	XTAL1	Input	Crystal Reference oscillator input.	Connect to 16 MHz crystal and load capacitor.
27	XTAL2	Input/Output	Crystal Reference oscillator output Note: Do not load this pin by using it as a 16 MHz source. Measure 16 MHz output at Pin 15, CLKO, programmed for 16 MHz.	Connect to 16 MHz crystal and load capacitor.
28	VDDL02	Power Input	LO2 VDD supply. Connect to VDDA externally.	
29	VDDL01	Power Input	LO1 VDD supply. Connect to VDDA externally.	
30	VDDVCO	Power Output	VCO regulated supply bypass.	Decouple to ground.
31	VBATT	Power Input	Analog voltage regulators Input. Connect to Battery.	Decouple to ground.

Table 2-1. Pin Function Description (continued)

Pin #	Pin Name	Type	Description	Functionality
32	VDDA	Power Output	Analog regulated supply Output. Connect to directly VDDLO1 and VDDLO2 externally and to PAO± through a frequency trap. Note: Do not use this pin to supply circuitry external to the chip.	Decouple to ground.
EP	Ground		External paddle / flag ground.	Connect to ground.

Not recommended for New Designs.
MC1320X.

Chapter 3

System Considerations

3.1 Introduction

The MC13192 is the embodiment of an 802.15.4 Standard transceiver in a single QFN package which can provide solutions to proprietary nets, 802.15.4 Standard MAC-compatible nets, or full ZigBee-compatible nets. All control to the modem is through the common SPI bus, the MCU interrupt request, and several MCU GPIO lines. Primary interface with the modem is through the SPI command structure that allows reading/writing modem registers and provides initialization of parameters, reading of status, and control of modem operation. The modem can ask for real time response through the interrupt request signal.

This chapter presents information regarding operation of the modem from a system level. The areas considered here are also covered in greater detail in the following sections of the book. The book is organized such that the first three chapters present the top-level view of the MC13192 device and the following chapters present individual functions with detailed descriptions.

3.2 Power Connections

The MC13192 power connections are listed in [Table 3-1](#).

Table 3-1. Power Pin Descriptions

Pin #	Pin Name	Type	Description	Functionality
22	VDDINT	Power Input	Digital interface supply & digital regulator input. Connect to Battery.	2.0 to 3.4 V. Decouple to ground.
21	VDDD	Power Output	Regulated output supply voltage	Decouple to ground.
31	VBATT	Power Input	Voltage regulators' input. Connect to Battery	Decouple to ground.
32	VDDA	Power Output	Analog regulated supply output	Decouple to ground. Connect to directly VDDLO1 and VDDLO2 externally.
30	VDDVCO	Power Output	Modem VCO regulated supply bypass	Decouple to ground.
29	VDDLO1	Power Input	Modem LO1 VDD supply	Connect to VDDA externally.
28	VDDLO2	Power Input	Modem LO2 VDD supply	Connect to VDDA externally.
EP	VSS	Power input	External package flag. Common VSS	Connect to ground.

System Considerations

When designing power to the device, the following points need to be considered:

- The QFN package has a single common EP ground flag (VSS).
- There are two primary power inputs which include VBATT for modem power and VDDINT for digital interface power.
- For logic level compatibility between the modem and the system CPU, VBATT, and VDDINT must be connected with the CPU to a common source supply of 2.0 - 3.4 VDC.
- Input VBATT feeds the common supply to the analog and digital circuitry regulators. The analog regulator output VDDA is provided both for bypassing and to supply VDDL01 and VDDL02 which are the power rails for the local oscillators.
- Output VDDVCO is provided to allow separate bypass of the modem radio VCO regulated supply.

Power supply connections are shown in [Figure 3-1](#).

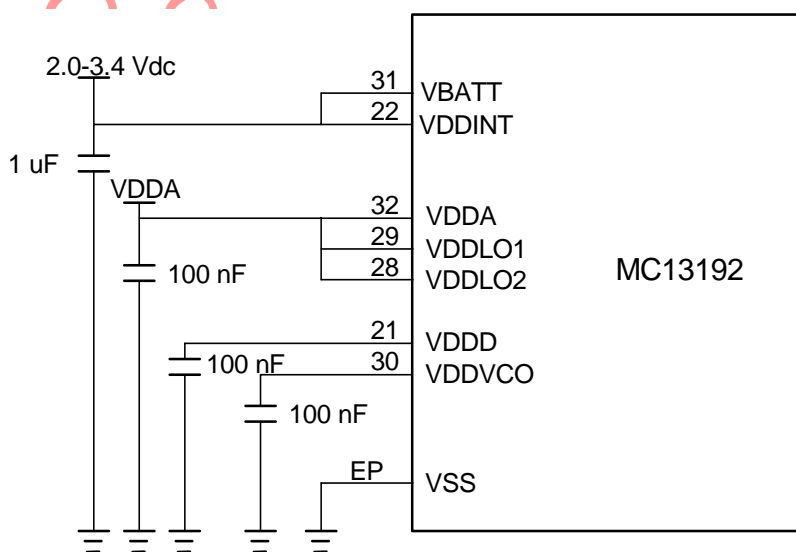

Figure 3-1. MC13192 Power Supply Connections

NOTE

There are separate bypass capacitors on VDDA, VDDD, and VDDVCO. In some RF circuitry configurations, VDDA may also need to be DC-coupled to the radio PA outputs.

3.3 Test Pin SM

Input SM is a test pin that must be grounded for normal operation.

3.4 Reset Usage

The modem active low reset input $\overline{\text{RST}}$ is recommended to be driven from an MCU GPIO pin. In the interest of lowest power, there is no external pull-up resistor on input $\overline{\text{RST}}$. An MCU GPIO programmed as an output typically also has a software controlled pull-up resistor. However, it would normally not be

used because the modem can be held in hardware reset by the MCU for extended periods of time. The transceiver $\overline{\text{IRQ}}$ pullup can also be disabled, and having no resistor makes for lowest power applications.

From a power-on or “cold start” condition, the MCU GPIO normally initiates as a high-impedance input with its internal pull-up disabled and the $\overline{\text{IRQ}}$ pullup is enabled which holds the modem reset input high. As part of the MCU initialization, GPIO must be programmed as an output and then driven low to reset the modem. The $\overline{\text{RST}}$ input is asynchronous and needs to be held low for only a short period.

In the reset condition, the modem is totally powered down and no clocks are available. After $\overline{\text{RST}}$ is released, the modem will power up, initialize, and go to its idle condition within 10 - 25 milliseconds, and in turn, this causes an ATTN interrupt request and allows CLKO to start toggling at 32.768+ kHz (both of which are default conditions). The ATTN hardware interrupt request is normally caused by asserting modem signal $\overline{\text{ATTN}}$, however, coming out of reset the ATTN status bit is set and the ATTN interrupt request mask is set.

Once the interrupt request is seen by the MCU, the MCU can assume the modem is alive and ready for programming via the SPI bus. Modem reset operation and control is detailed in [Chapter 9, “Miscellaneous Functions](#).

3.5 MC13192 Interface to MCU

The modem interacts with the host MCU through its SPI interface, interrupt request, and several status and control signals.

3.5.1 SPI Command Channel

Primary interface with the modem is through the SPI command structure that allows reading/writing modem registers and provides initialization of parameters, reading of status, and control of modem operation. The modem is a slave only and the MCU SPI must be programmed and used as a master only. Further, the SPI performance is limited by the modem constraints of 8 MHz maximum SPI clock frequency, and use of the MCU SPI must be programmed to meet the modem SPI protocol. The SPI bus connections for a Freescale 9S08 typically are:

- MCU MOSI1 output drives modem MOSI.
- Modem MISO output drives MCU MISO1.
- MCU SPCK1 output drives modem SPICLK.
- MCU $\overline{\text{SS1}}$ output drives modem $\overline{\text{CE}}$.

The use and programming of the SPI command channel is described in [Chapter 5, “Serial Peripheral Interface \(SPI\)](#).

3.5.2 Interrupt Request to MCU

The modem interrupt request $\overline{\text{IRQ}}$ is an active low open drain output that is asserted when an interrupt request is pending. The signal is released to high by reading the modem `IRQ_Status` register via a SPI transaction. $\overline{\text{IRQ}}$ has a programmable pull-up resistor (default is active) and the output also can be programmed for drive strength. $\overline{\text{IRQ}}$ is covered in detail in [Section 8.1.2, “Output Pin IRQ](#), and [Section 8.1, “Interrupts](#).

The $\overline{\text{IRQ}}$ maximum drive strength is suggested as this will give fastest performance for the interrupt fall time.

3.5.3 Modem Control Signals

The modem requires two additional input control signals that are typically controlled by the MCU GPIO:

- $\overline{\text{ATTN}}$ - is an active low attention signal that is used wake the modem from Hibernate or Doze Mode. An MCU GPIO must be programmed as an output and controls this input.
- `RXTXEN` - is an active high input used to enable transmit, receive, and CCA operations in the modem. An MCU GPIO usually is programmed as an output and controls this input.

3.5.4 Modem Status Signals

The modem has two programmable signals that can provide real-time status to the MCU:

- `GPIO1/Out_of_Idle` output - The modem GPIO1 signal can optionally be programmed as an “out-of-idle” indicator for monitoring RX, TX, or CCA operation. An MCU GPIO must be programmed as an input to monitor this signal. The modem GPIO1 signal can also be used as a general purpose IO.
- `GPIO2/CRC_Valid` output - The modem GPIO2 signal can optionally be programmed as an “CRC valid” indicator for monitoring an RX operation. An MCU GPIO must be programmed as an input to monitor this signal. The modem GPIO2 signal can also be used as a general purpose IO.

3.6 System Oscillator and Clock Considerations

3.6.1 Modem Crystal Oscillator

The modem oscillator source must always be present and an external crystal is used to implement the oscillator. The source frequency must be 16 MHz with a total accuracy of +/- 40 ppm or greater as required by the 802.15.4 Standard. A detailed discussion of required crystal characteristics is in [Section 9.3.1, “Crystal Requirements](#).

In [Figure 3-2](#) crystal X1 and capacitors C1 and C2 form the modem crystal oscillator circuit. An onboard feedback resistor of approximately 1 MOhm (not shown) between input XTAL1 and output XTAL2 provides DC biasing for the oscillator buffer. An important parameter for the 16 MHz crystal X1 is a load capacitance of <9 pF. The oscillator needs to see a balanced load capacitance at each terminal of about 18pF. As a result, the sum of the stray capacitance of the PCB, device pin (XTAL1 or XTAL2), and load

capacitor (C1 or C2) at each terminal must equal about 18 pF. C1 and C2 are typically values of 6-9 pF. Higher values can load the crystal buffer and cause oscillator start-up problems.

As described in Section 9.3.2, “Crystal Trim Operation, the MC13192 crystal oscillator frequency can be trimmed by programming modem CLKO_Ctl Register 0A, Bits 15-8 (xtal_trim[7:0]). The trimming procedure varies the frequency by a few hertz per step, depending on the type of crystal. As xtal_trim[7:0] is increased, the frequency is decreased. This feature is useful for factory calibration of the crystal frequency to set the accuracy for the radio as required by the 802.15.4 Standard.

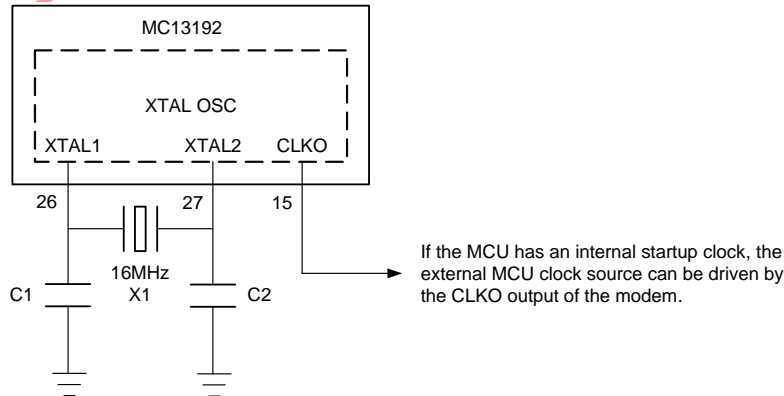

Figure 3-2. MC13192 Oscillator and External Clock Connections

3.6.2 System Clock Configurations

Because of the multiple clock configurations in an MCU and the CLKO output from the modem, there are a number of variations for system clock configurations. Key considerations for any system clock configuration are:

- The modem 16 MHz source (typically the crystal oscillator) must always be present. The crystal has special requirements and the reference frequency must meet 802.15.4 Standard requirements.
- Battery-operated application requirements for low power can impact the choices for MCU clock source.
- The system clock configuration can impact system initialization procedures.
- Software requirements can impact MCU processor and bus speed. The user must be aware of the performance requirements for the MCU. In the Freescale software running on the 689S08, the CPU clock is always 2X the internal bus speed, and the application software such as the Freescale BeeStack and/or the 802.15.4 Standard MAC require either an 8 MHz or 16 MHz bus rate. The implication is that the MCU clock source must be capable of generating these bus speeds.

3.6.3 Single System Crystal with CLKO driving MCU crystal input

The single crystal (modem crystal) with CLKO driving the MCU external clock input is a common configuration for low cost and excellent frequency accuracy. The CLKO frequency is programmable from 16.393+ kHz to 16 MHz and drives the MCU external source.

NOTE

For this system option to be usable, the system MCU must have an alternative (typically onboard) start-up clock.

In this configuration, clock start-up from a reset condition involves:

- MCU reset is released and MCU starts on an internal clock.
- Initialization software must reset and then release reset to the modem (MCU still running on start-up clock).
- Wait for modem start-up interrupt request (approximately 10 - 25 msec). CLKO default is active with a frequency of 32.786+ kHz.
- Program CLKO to a different frequency (if desired).
- Wait for the CLKO source to lock, and then switch MCU clock to external source.

Additional considerations for this mode of operation include:

- If the modem is forced to the Off condition and CLKO is killed, there is a 10 - 25 msec wait for the modem CLKO to start from the Off condition after $\overline{\text{RST}}$ is released.
- If the MCU puts the modem into Doze mode, keeping the CLKO alive is a higher power, but available option.
- If an accurate period is required for longer time delays (such as a beacon period), keeping CLKO alive for very long periods is an option, but would be a higher power option typically than using a separate crystal for the MCU.

3.7 GPIO Characteristics

The modem GPIO hardware consists of 7 signals total (GPIO1-GPIO7). Immediately after reset, all the GPIO pins are configured as high-impedance general-purpose inputs. There are no internal pullup devices on these pins.

NOTE

To avoid extra current drain from floating input pins, the power up initialization routine in the application program should change the direction of unused pins to outputs (programmed low) so the pins do not float. Outputs programmed low is the preferred option for lowest power.

As described in [Section 3.5.4, "Modem Status Signals](#), GPIO1 and GPIO2 can be programmed as special status signals. The alternate functionality of the GPIO1-GPIO2 are controlled by the applications program and use of these pins is described in [Chapter 9, "Miscellaneous Functions](#).

The functionality of the modem GPIO is controlled by programming of the modem SPI registers via the SPI interface. For information about controlling all these pins as general-purpose I/O pins, see [Chapter 9, “Miscellaneous Functions.”](#)

3.8 MC13192 Digital Signal Properties Summary

Table 3-2 summarizes digital I/O pin characteristics. These characteristics are determined by the way the common pin interfaces are hard-wired to internal circuits.

Table 3-2. MC13192 Digital Signal Properties

Pin Name	Dir	High Current Pin	Output Slew ¹	Pull-Up ²	Comments
$\overline{\text{IRQ}}$	O	N	SWC	SWC	Open drain
XTAL1	I	—	—	N	
XTAL2	O	N	N	N	
$\overline{\text{ATTN}}$	I	—	—	N	
RXTXEN	I	—	—	N	
$\overline{\text{RST}}$	I	—	—	N	
CLKO	O	N	SWC	N	
SPICLK	I	—	—	N	
MOSI	I	—	—	N	
MISO	O	N	SWC	N	Off state is SWC
$\overline{\text{CE}}$	I	—	—	N	
GPIO1/Out_of_Idle	I/O	N	SWC	N	Programmable status bit
GPIO2/CRC_Valid	I/O	N	SWC	N	Programmable status bit
GPIO3	I/O	N	SWC	N	
GPIO4	I/O	N	SWC	N	
GPIO5	I/O	N	SWC	N	
GPIO6	I/O	N	SWC	N	
GPIO7	I/O	N	SWC	N	

¹ SWC is software controlled slew rate, the register is associated with the respective port.

² SWC is software controlled pull-up resistor, the register is associated with the respective port.

3.9 Transceiver RF Port Operation and External Connections

The MC13192 radio has features that allow for a flexible as well as low cost RF interface:

- Programmable output power - 0 dBm nominal output power, programmable from -27 dBm to +3 dBm typical
- <-92 dBm (typical) receive sensitivity - At 1% PER, 20-byte packet (well above 802.15.4 Standard of -85 dBm)
- A full differential set of RF RF_IN signals and a separate set of full differential PA outputs are provided. Separate inputs and outputs allow for a variety of RF configurations including external LNA and PA for increased range
- Onboard trim capability for 16 MHz crystal reference oscillator - The 802.15.4 Standard puts a +/- 40 ppm requirement on the carrier frequency. The onboard trim capability of the modem crystal oscillator eliminates need for external variable capacitors and allows for automated production frequency calibration. Also tighter tolerance can produce greater receive sensitivity

The RFIN+ and RFIN- are receive inputs only, and PAO+ and PAO- are the differential PA output pins. These signals support a full differential dual port radio interface. Multiple external hardware configurations are possible.

Figure 3-3 shows two dual port configurations. First is a single antenna configuration with an external low noise amplifier (LNA) for greater range. An external antenna switch is used to multiplex the antenna between receive and transmit. An LNA is in the receive path to add gain for greater receive sensitivity. Two external baluns are required to convert the single-ended antenna switch signals to the differential signals required by the radio. An MCU GPIO signal is typically used to change direction of the antenna switch.

Figure 3-3 also shows a dual antenna configuration where there is a RX antenna and a TX antenna. For the receive side, the RX antenna is ac-coupled to the differential RFIN inputs and these capacitors along with inductor L1 form a matching network. Inductors L2 and L3 are ac-coupled to ground to form a frequency trap. For the transmit side, the TX antenna is connected to the differential PAO outputs, and inductors L4 and L5 provide DC-biasing to VDDA but are ac isolated. This dual antennae approach is a low cost option as the antennae can be printed wire devices.

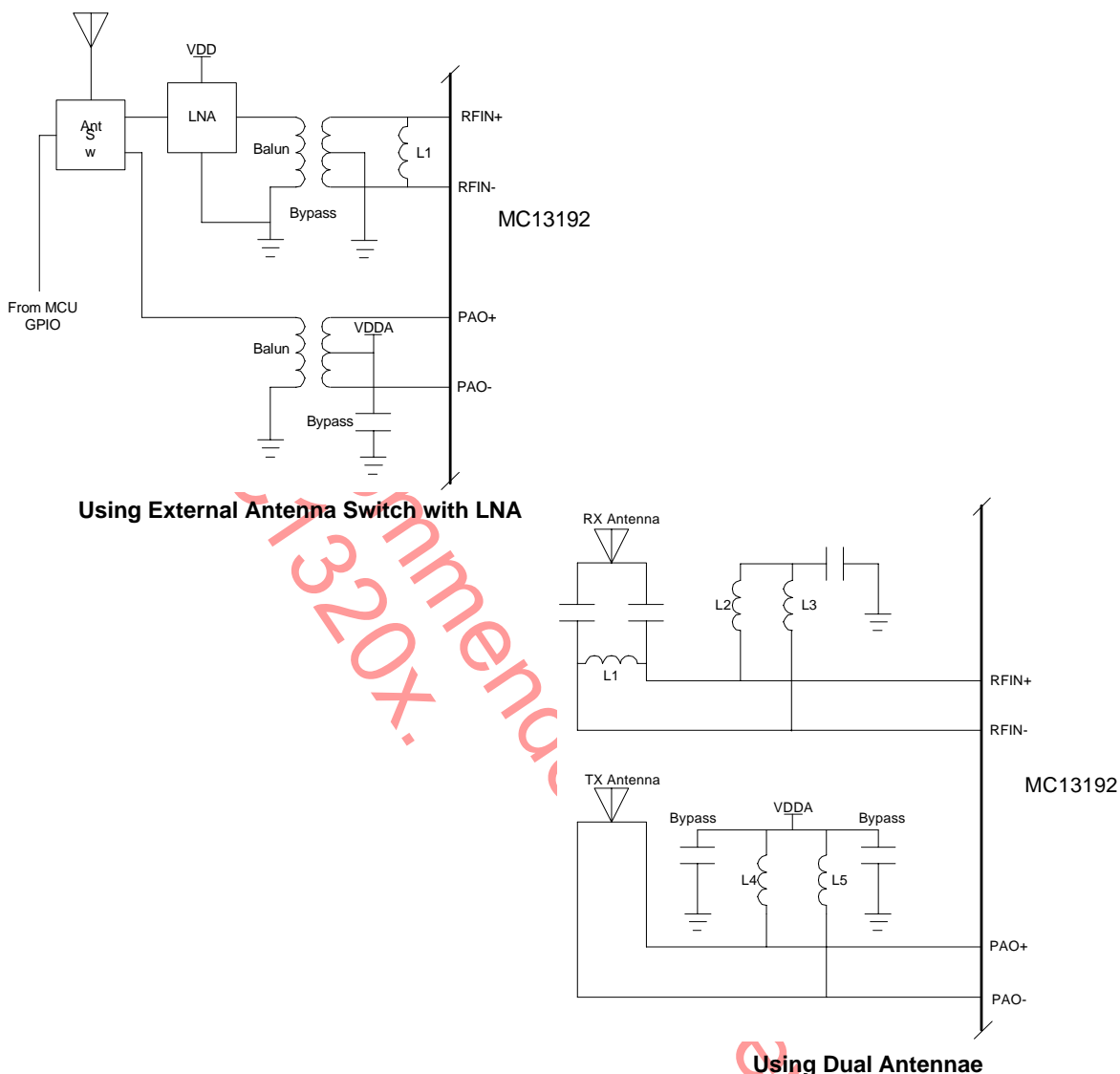

Figure 3-3. Dual Port RF Configuration Examples

3.10 Low Power Considerations

Many ZigBee and/or 802.15.4 Standard applications such as sensor End Devices are required to be battery operated. As expected, long battery life is highly desirable and is very dependent on application parameters. Over-the-air operation uses RX, TX, and CCA modes, where power is highest. As a result, the time between radio operations should be kept at the longest possible period that the application will allow.

When designing low power operation of the MC13192 consider:

- The modem has several low power options.
- The modem is entirely controlled by the MCU; the low power options/combinations will be determined by MCU programming.

System Considerations

- The power down control of the modem must be maintained by the MCU in the MCU's power down configuration.

Lowest power in a system is more than just putting the modem and/or the MCU in a low power mode. The relationship between the functions, the timing between them, and clock management must all be considered. The duty cycle between active operations is also very important as it can impact whether sleep operation or active operation will have the biggest impact over an extended time period.

3.10.1 Modem Low Power States

Table 3-3 lists the modem low power states and the modes are covered in detail in Chapter 6, "Modes of Operation". There are three low power modes available:

- Off - Requires the modem reset $\overline{\text{RST}}$ input to stay asserted low. Lowest possible power and all functions are disabled. Digital GPIO default to inputs.
- Hibernate - Has next lowest power, all hardware blocks deactivated, RAM and SPI register data are retained. Digital I/O retain their state.
- Doze - Allows use of the Event Timer when active. The Event Timer can be used to cause a timed exit from Doze, and the CLKO output can be kept active in Doze to provide a clock to the MCU. Doze uses considerable more current than Off or Hibernate. RAM and register data are retained and digital I/O retain their state.

Table 3-3. MC13192 Modem Low Power States

Mode	Current (typical @ 2.7V)	Advantages	Disadvantages	Comment
Off	0.2 μA	Lowest power (leakage only)	Digital outputs tristated. All RAM/register data lost.	$\overline{\text{RST}}$ must remain asserted. All IC functions off.
Hibernate	1.0 μA	RAM/register data retained. Digital outputs retain their states.		$\overline{\text{ATTN}}$ or $\overline{\text{M_RST}}$ used to exit state.
Doze ¹	35 μA (no CLKO)	Crystal reference oscillator is on and CLKO can be enabled. Timed exit is possible. RAM/register data retained. Digital outputs retain their states.	Much higher current than Hibernate or Off.	Can exit on $\overline{\text{ATTN}}$ or $\overline{\text{RST}}$ or timed exit is option. CLKO can be kept active as a clock source.
Idle	500 μA	Fast transition to RX, TX, CCA	Much higher current than Doze or Hibernate	State from which all TX, RX or CCA is initiated.

¹ CLKO frequency at default value of 37.786 kHz.

Although Idle is not considered a low power state, it is listed in Table 3-3 for comparison. It is also important to remember that all active states of RX, TX and CCA must be initiated from the Idle condition.

3.10.2 Special Considerations for Hibernate and Doze Low Power Modes

When using Hibernate or Doze mode, consideration must be given to the following issues.

3.10.2.1 Doze Current Higher Than Specified

The Doze current (no CLKO output active) is specified as 35 μ A (typical) on the data sheet with the programmed CLKO frequency at a default of 32.786 kHz. The Doze current can be considerably higher for certain combinations of higher CLKO frequencies and event timer prescale options. These combinations consist of:

1. CLKO frequency = 16 MHz with prescale select at 5, 6, or 7.
2. CLKO frequency = 8 MHz with prescale select at 6, or 7.
3. CLKO frequency = 4 MHz with prescale select at 7.

All other combinations have no problems. The higher current will not occur every time Doze is enabled. There is no potential harm either to the transceiver or its operation, the Doze current is simply higher.

To work around this issue, there are three choices:

1. Accept higher current in Doze mode.
2. Do not use any of the described combinations in Doze mode.
3. If a higher CLKO frequency is desired when using CLKO as an MCU clock source, and the desired prescale select can cause a problem, just before entering Doze mode, program the CLKO frequency to a lower value. Next, use the desired prescale value while in Doze. Finally, after exiting Doze mode, reprogram CLKO to the desired frequency before releasing the MCU clock to the CLKO source.

3.10.2.2 Asserting \overline{ATTN} Early to Exit Hibernate or Doze Mode

Asserting \overline{ATTN} early can cause a problem if the transceiver has not fully entered Hibernate or Doze mode. Once the transceiver has been programmed to enter either Hibernate or Doze, the device does not fully enter the low power mode until 128 CLKO cycles have transpired. This is true whether or not the CLKO output is enabled. If the CLKO delay time is still active and \overline{ATTN} is asserted, the IRQ for exiting the low power mode will be asserted, but reading the IRQ_Status register during the interrupt service routine will return no active bits. The status bit for exiting low power mode will not be set.

This situation can cause a problem with the interrupt service routine if the service routine does not return an interrupt source.

The delay time can vary from 128 clock cycles @ 16.393 kHz or ~7.8 msec to 128 clock cycles @ 16 MHz or 8 μ sec. This is dependent on the selected CLKO frequency.

To work around this issue, there are three choices:

1. Prevent the application from asserting \overline{ATTN} during this period. As an example, for an End Node that is sleeping for long periods, this would present no problems.

System Considerations

2. If there is a potential for an early transceiver wake-up, program CLKO to a high frequency before entering Hibernate or Doze. The software can prevent an early wake-up within the short 8 μ sec time. If this approach is used, [Section 3.10.2.1, “Doze Current Higher Than Specified”](#) above must also be considered.
3. Write the application software knowing that an interrupt from exiting low power mode may not generate a valid status bit.

3.10.3 Recovery Times from Low Power Modes

The mode of operation is controlled by the MCU. The modem may be powered down if it is not in use while the MCU is doing another task or while the whole node is “sleeping”, i.e., the MCU is also powered down. Recovery time for both the modem and the MCU are important to system performance and the recovery times are independent of each other.

Each of the modem recovery times is from the low power condition to the Idle state. The start-up times for the Off and Hibernate conditions are considerably longer due to the start-up of the voltage regulators and clock oscillator. [Figure 3-4](#) shows a simplified state diagram for the low power modes and gives the transition time to Idle:

- Off > Idle (10 - 25 ms) - The Off state is released by negating $\overline{\text{RST}}$ high. From that time until the modem asserts a $\overline{\text{ATTN}}$ interrupt and CLKO starts with a default frequency of 32.786+ kHz is 25 ms maximum.
- Hibernate > Idle (8 - 20 ms) - The Hibernate state is normally released via asserting $\overline{\text{ATTN}}$ low. The start-up time at 20 ms maximum is a little quicker than from the Off condition. The modem also asserts a $\overline{\text{ATTN}}$ interrupt (if enabled) and CLKO starts (if enabled) with the value programmed before entering Hibernate.
- Doze > Idle ((300 + 1/CLKO) μ s) - The Doze state can be released via a timer or asserting $\overline{\text{ATTN}}$ low. The start-up time is considerably less ((300 + 1/CLKO) μ s) because the clock oscillator is already running. CLKO can be programmed to run during Doze, and if not, CLKO will start if enabled for normal operation. An $\overline{\text{ATTN}}$ interrupt will be asserted (if enabled) when $\overline{\text{ATTN}}$ is used to exit Doze, or an interrupt will be asserted for exiting Doze Mode via a timer.

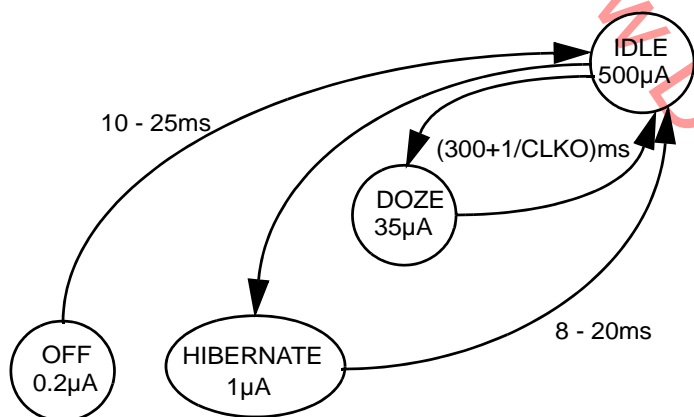

Figure 3-4. MC13192 Modem Low Power Recovery Times

3.10.3.1 Modem Active Currents

In normal operational mode the modem's rest state in the Idle Mode. All active sequences originate from the Idle Mode and return to the Idle Mode. The three active sequences are Clear Channel Assessment (CCA), RX, and TX, and each has a separate current profile. Table 3-4 lists the typical currents while in the listed modes, but does not show the transition profiles when moving between modes.

Table 3-4. MC13192 Active State Currents

Mode	Current (typ @ 2.7V)
Idle	500 μ A
CCA/ED	37 mA
RX	37 mA
TX (0 dBm nominal output power)	30 mA

A normal sequence of events may include an 802.15.4 Standard node performing first a CCA to see if the channel is clear, second transmitting a frame (assuming the channel is clear), and finally after the TX, going into to Receive Mode to look for an acknowledgement. The modem must be programmed for each of the operations separately and each operation has a different timing profile.

3.10.3.1.1 Modem CCA/ED Timing profile

The modem will scan for detected energy in a CCA operation (CCA is covered in detail in Section 6.3.5, "Clear Channel Assessment (CCA) Modes (including Link Quality Indication)"). This is really a special case of RX so the CCA current is the same as RX. There are two versions of CCA where one is called CCA and the second is called Energy Detect (ED).

Figure 3-5 shows the timing profiles for both variations of a CCA operation. Once the CCA operation is initiated, the state machine moves through a warm-up period of 144 μ s in which the analog regulators turn on and the analog RX circuitry comes to full power. The actual CCA or ED operation lasts 134 μ s or 198 μ s, respectively. During the warm-up period, the modem current is ramping from idle current (typically 500 μ A) to full CCA current (typically 37 mA). The modem current for the CCA or ED is the full CCA current. After the CCA/ED operation times out, the return to idle current is very quick.

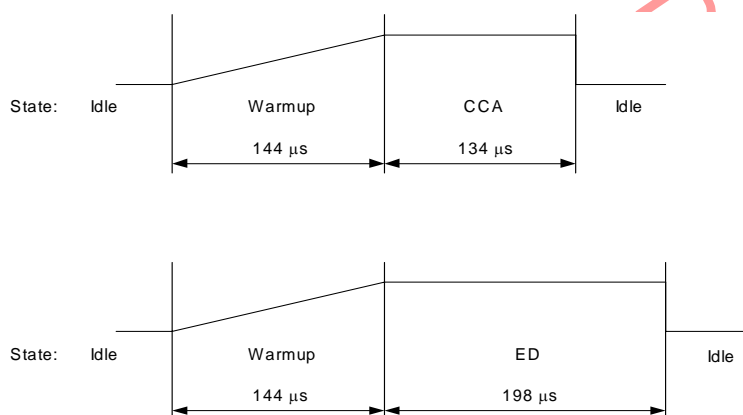

Figure 3-5. CCA and ED Timing Profiles

3.10.3.1.2 Modem RX Timing profile

The receive or RX timing profile is very similar to the CCA profile. [Figure 3-6](#) shows the timing profile for an RX operation. There is the initial 144 μs warm-up period from idle current to full RX current (typically 37 mA) followed by the RX operation (RX is covered in detail in [Section 6.3, “Active Modes”](#)). The RX time is not a set figure as it is in a CCA operation. In some applications (typically not battery operated) such as a Coordinator, the receiver can be turned on for a majority of the time listening for End Devices or Routers. In an End Device (typically battery operated), the receiver can be typically turned on only when expecting an acknowledgement (ACK) of a transmission. The worst case RX on time can be when no ACK is received and the RX operation times out with not having received a frame.

The RX operation will end based on receiving the end of a frame or being terminated by the application having timed-out and aborted the RX operation. The return to Idle happens very quickly.

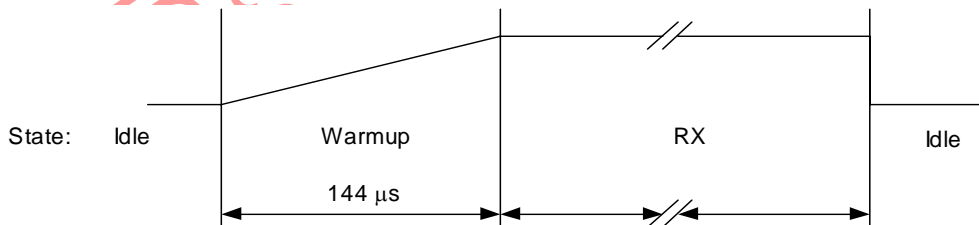

Figure 3-6. RX Timing Profile

3.10.3.1.3 Modem TX Timing profile

The transmit or TX timing profile is more predictable than the RX profile. [Figure 3-7](#) shows the timing profile for a TX operation. There is the usual initial 144 μs warm-up period from idle current to full TX current (typically 30 mA) followed by the TX operation (TX is covered in detail in [Section 6.3, “Active Modes”](#)). The TX time is not a set figure but it is predictable.

The raw transmission rate of the 802.15.4 Standard 2.4 GHz physical layer is 62.5 ksymbols/s or 250 kb/s. This means the TX time for 2 symbols or 1 byte of data is 32 μs . An 802.15.4 2.4 Standard compliant packet has 4 bytes of preamble, 1 byte of SFD, 1 byte of FLI, 2 bytes of FCS plus the payload data (125 bytes maximum). As a result the, the overhead of a frame is 8 bytes or $8 \times 32 = 256 \mu\text{s}$, and the maximum payload TX time is $125 \times 32 = 4000 \mu\text{s}$. The TX time for a packet then is:

$$\text{Total TX time } (\mu\text{s}) = 256 + (\text{payload bytes} \times 32)$$

The TX operation will end after the FCS bytes are sent. The return to Idle has a “warm down” period of 10 μs to allow the RF transmitter to taper off in a manner to avoid RF “splatter”.

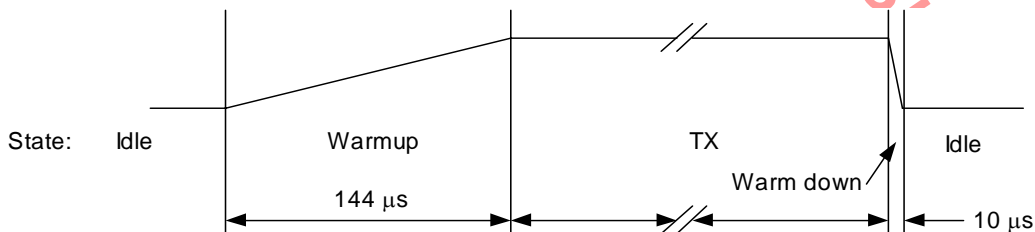

Figure 3-7. TX Timing Profile

3.10.4 General System Considerations for Low Power

Low power is most important for battery operated applications such as 802.15.4 Standard End Devices. In the modem the highest instantaneous power is dominated by the CCA, RX and TX modes. In the MCU, the current draw is typically dominated by the clock frequency. A number of general recommendations can help the user:

- Clock Management on the MCU
 - Use clock management as required to lower required power.
 - Run fast when the CPU performance is the critical path.
 - Run slow when waiting on peripherals (such as ATD conversion).
 - Be aware of software performance requirements (run time bus clock may need to be 16 MHz).
 - Use the external clock option for lowest power if possible (modem CLKO can supply frequencies as high as 16 MHz).
- The MCU can go to a lower power mode when the modem is recovering from the Off (10 - 25 ms) or the Hibernate modes.
- When the MCU is initializing from a “cold start” POR condition, the modem reset must be driven to a low condition early in the routine. This is so the modem will start from a known condition and low power.
- Profile the use scenario of both the modem and the MCU when they are active. This is required to estimate current usage versus time and mode of operation.
- If possible, put the modem in a low power mode when the MCU is active and does not require interface with the modem. Doze can be useful to save power, provide CLKO, and be ready with a quick recovery time.
- Alternately put the MCU in a lower power mode if waiting on the modem IRQ.
- Program all unused GPIO on both the modem and the MCU as outputs for lowest power.
- The default condition is for MISO to go to tristate when CE is de-asserted. Program Control_B Register 07, Bit 11, miso_hiz_en = 0 so MISO will be driven low when CE is de-asserted. As a result MISO will not float when Doze or Hibernate Mode is enabled.

Not Recommended for New Designs.
Use MC1320X.

Chapter 4

SPI Register Descriptions

4.1 Overview

All control, reading of status, writing of data, and reading of data is done through the MC13192 SPI port. The host microcontroller accesses the transceiver through SPI “transactions” in which multiple bursts of byte-long data are transmitted on the SPI bus. Each transaction is three or more bursts long depending on the transaction type, and these are described in detail in [Section 5.2.2, “SPI Burst Operation”](#).

Transactions are always read accesses or write accesses to register addresses. The associated data for any single register access is always 16 bits in length. This chapter describes all the registers that users should access in the MC13192. Undocumented addresses should not be accessed.

NOTE

Register default values for reserved fields should not be modified unless specifically noted. Freescale recommends that all writes to control register fields that only modify part of the 16-bit word be done as a read-modify-write operation.

4.2 Mandatory Register Initialization

NOTE

Certain hidden registers **MUST** be initialized to given conditions for proper operation of the transceiver. These programmed conditions are given in [Table 4-1](#) (these are not default values).

Table 4-1. Mandatory Register Initialization

ADD (Hex)	BIT	CONDITION
08	1	Set to 1
08	4	Set to 1
11	9:8	Set to 00
06	14	Set to 1

For reference, the reset default values for the above registers are as follows:

Register 0x06 (default) = 0x0010

Register 0x08 (default) = 0xFFE5

Register 0x11 (default) = 0x21FF

4.3 Register Model and Description Details

Table 4-2 summarizes the MC13192 Register Model and the following sections describe each register in more detail.

Table 4-2. MC13192 SPI Register Table

REGISTER NAME	Add (Hex)	15	14	13	12	11	10	9	8	7	6	5	4	3	2	1	0	
Reset	00	software_reset																
RX_Pkt_RAM	01	rx_pkt_ram[15:0]																
TX_Pkt_RAM	02	tx_pkt_ram[15:0]																
TX_Pkt_Ctl	03	tx_ram2_select																tx_pkt_length[6:0]
CCA_Thresh	04	cca_vt[7:0]								power_comp[7:0]								
IRQ_Mask	05	attn_mask			ram_addr_mask	arb_busy_mask	strm_data_mask	pll_lock_mask	acoma_en				doze_mask	tmr4_mask	tmr3_mask	tmr2_mask	tmr1_mask	
Control_A	06			tx_strm	rx_strm	cca_mask	tx_sent_mask	rx_rcvd_mask	tmr_trig_en			cca_type[1:0]					xcvr_seq	
Control_B	07	tmr_load			miso_hiz_en		clko_doze_en		tx_done_mask	rx_done_mask	use_strm_mode					hib_en	doze_en	
PA_Enable	08	pa_en																
Control_C	09								gpio_alt_en		clko_en						tmr_prescale[2:0]	
CLKO_Ctl	0A	xtal_trim[7:0]															clko_rate[2:0]	

Table 4-2. MC13192 SPI Register Table (continued)

REGISTER NAME	Add (Hex)	15	14	13	12	11	10	9	8	7	6	5	4	3	2	1	0
GPIO_Dir	0B	gpio1234_drv[1:0]		gpio7_oen	gpio6_oen	gpio5_oen	gpio4_oen	gpio3_oen	gpio2_oen	gpio1_oen	gpio7_ien	gpio6_ien	gpio5_ien	gpio4_ien	gpio3_ien	gpio2_ien	gpio1_ien
GPIO_Data_Out	0C	gpio567_drv[1:0]		miso_drv[1:0]		clko_drv[1:0]		irqb_drv[1:0]		irqb_pup_en	gpio7_o	gpio6_o	gpio5_o	gpio4_o	gpio3_o	gpio2_o	gpio1_o
LO1_Int_Div	0F								lo1_idiv[7:0]								
LO1_Num	10	lo1_num[15:0]															
PA_Lvl	12								pa_lv_coarse[1:0]		pa_lv_fine[1:0]		pa_drv_coarse[1:0]		pa_drv_fine[1:0]		
Tmr_Cmp1_A	1B	tmr_cmp1_dis								tmr_cmp1[23:16]							
Tmr_Cmp1_B	1C	tmr_cmp1[15:0]															
Tmr_Cmp2_A	1D	tmr_cmp2_dis								tmr_cmp2[23:16]							
Tmr_Cmp2_B	1E	tmr_cmp2[15:0]															
Tmr_Cmp3_A	1F	tmr_cmp3_dis								tmr_cmp3[23:16]							
Tmr_Cmp3_B	20	tmr_cmp3[15:0]															
Tmr_Cmp4_A	21	tmr_cmp4_dis								tmr_cmp4[23:16]							
Tmr_Cmp4_B	22	tmr_cmp4[15:0]															
TC2_Prime	23	tc2_prime[15:0]															

Table 4-2. MC13192 SPI Register Table (continued)

REGISTER NAME	Add (Hex)	15	14	13	12	11	10	9	8	7	6	5	4	3	2	1	0
IRQ_Status	24	pll_lock_irq	ram_addr_err	arb_busy_err	stm_data_err		attn_irq	doze_irq	tmr1_irq	rx_rcvd_irq	tx_sent_irq	cca_irq	tmr3_irq	tmr4_irq	tmr2_irq	cca	crc_valid
RST_Ind	25									reset_ind							
Current_Time_A	26									et[23:16]							
Current_Time_B	27	et[15:0]															
GPIO_Data_In	28		gpio7_i	gpio6_i	gpio5_i	gpio4_i	gpio3_i	gpio2_i	gpio1_i								
Chip_Id	2C	chip_id[8:0]															
RX_Status	2D	cca_final[7:0]										rx_pkt_latch[6:0]					
Timestamp_A	2E									timestamp[23:16]							
Timestamp_B	2F	timestamp[15:0]															
BER_Enable	30	ber_en															
PSM_Mode	31											psm_tm[2:0]					

4.4 Reset - Register 00

Writing to Reset Register 00 causes a reset condition where the digital logic is reset, but the transceiver is not powered down. The device is forced to the Idle Mode and the SPI registers are all reset and forced to their default condition although all data in the Packet RAMs is retained. The reset is held as long as \overline{CE} remains asserted and is released when \overline{CE} is negated high. A read of this register has no effect.



Table 4-3. Register 00 Description

Name	Description	Operation
Bits 15-0	software_reset — Writing this register provides a software reset. When there is a SPI write to Register 00, the IC is reset and stays reset as long as CE remains asserted, and returns to normal operation when CE is negated. Read of this register has no effect.	Write data is “don’t care”

4.5 RX_Pkt_RAM - Register 01

The receive Packet RAM register is accessed when the MC13192 is being used in Packet Mode or Stream Mode for data transfer. In Packet Mode once a packet has been received, the payload data is stored in the RX Packet RAM and the length of the packet data is contained in Register 2D, Bit 6-0. A recursive read (see [Section 5.5.1](#)) to the RX_Pkt_RAM Register 01 is required to access the RX packet payload data.

In Stream Mode, the receive payload data is accessed word-by-word via repeated read accesses on the SPI bus. During Stream Mode when a valid data word is available in RX_Pkt_RAM, a rx_strm_irq status is set and an interrupt is generated (it must be enabled). Reading the RX_Pkt_RAM register will clear the rx_strm_irq interrupt so that reading the IRQ_Status Register 24 is not required (see [Section 6.3.4.1](#)).

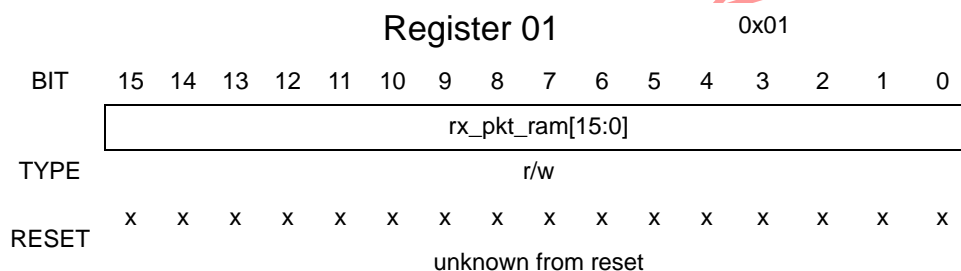

Table 4-4. Register 01 Description

Name	Description	Operation
Bits 15-0	rx_pkt_ram[15:0] — These bits are the data channel for host access to the receive Packet RAM.	Default from RST reset is indeterminate.

4.6 TX_Pkt_RAM - Register 02

The transmit Packet RAM register is accessed when the MC13192 is being used in Packet Mode or Stream Mode for data transfer. There are two transmit Packet RAMs and only one is accessed when the MC13192 is being used in Packet Mode for data transfer. In Packet Mode, the packet payload data must be written to the selected TX Packet RAM and the length of the packet data must be written to TX_Pkt_Ctl Register 03, Bits 6-0. A recursive write (see [Section 5.5.2](#)) to the TX_Pkt_RAM Register 02 is required to load the TX packet payload data.

In Stream Mode, the transmit payload data is written to Register 02 on a word-by-word basis via repeated accesses on the SPI bus. During Stream Mode when a data word is required for TX_Pkt_RAM, a tx_strm_irq status is set and an interrupt is generated (it must be enabled). Writing the TX_Pkt_RAM register will clear the tx_strm_irq interrupt so that reading the IRQ_Status Register 24 is not required (see [Section 6.3.4.3](#)).

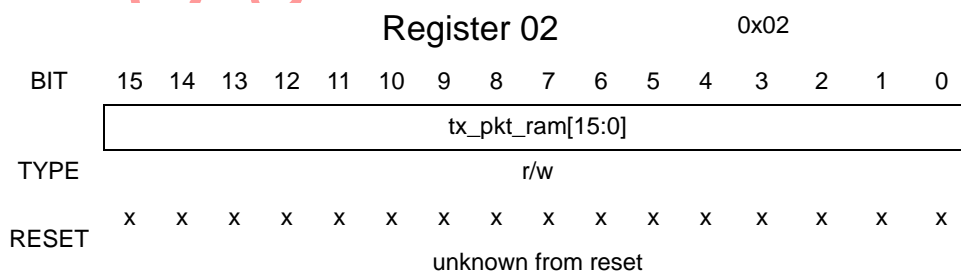

Table 4-5. Register 02 Description

Name	Description	Operation
Bits 15-0	tx_pkt_ram[15:0] — These bits are the data channel for host access to the selected transmit Packet RAM.	Default from reset is indeterminate.

4.7 TX_Pkt_Ctl - Register 03

The TX_Pkt_RAM_Ctl Register 03 contains two fields that control operation of the two transmit Packet RAMs. The first field tx_ram2_select, Bit 15, determines which of the transmit Packet RAMs is selected for present operations. The second field tx_pkt_length, Bits 6-0, defines the length of the payload data for a transmission data packet.

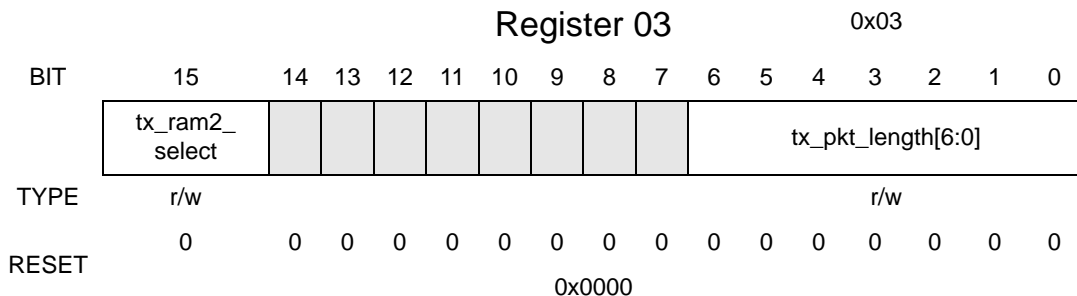

Table 4-6. Register 03 Description

Name	Description	Operation
Bits 14- 7	Reserved	Leave default
Bit 15	tx_ram2_select — The Transmit RAM select bit selects between transmit Packet RAM1 and transmit Packet RAM2 for operations involving transmit RAM. These include SPI read, SPI write, packet transmission and software error interrupts.	1 = tx_ram2_sel TX Packet RAM2 selected. 0 = tx_ram2_sel TX Packet RAM1 selected.
Bits 6 - 0	tx_pkt_length[6:0] — The Transmit Packet Length bits represent the number of bytes to be transmitted from transmit Packet RAM plus 2 bytes for FCS.	Total transmit payload data length in bytes

4.8 CCA_Thresh - Register 04

The CCA_Thresh Register 04 contains the `cca_vt[7:0]` 8-bit CCA threshold value, Bits 15 - 8. To calculate desired the `cca_vt[7:0]` value:

$$\text{Threshold value} = \text{hex} (| (\text{Threshold Power in dBm}) * 2 |)$$

A second field is `power_comp[7:0]`, Bits 7 - 0, (default = 0x8D) which is an offset that is divided by 2 and added to the measured value of the average energy from a CCA/ED function or LQI value from an RX function, and the resulting value is stored in `cca_final[7:0]`, RX_Status Register 2D. By using this `power_comp[7:0]` value, users can compensate the `cca_final[7:0]` value for external gain in the RX path. See [Section 6.3.5.1](#) for more detailed information.

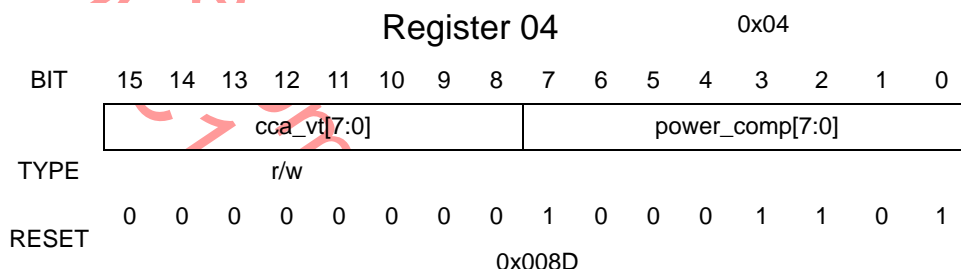

Table 4-7. Register 04 Description

Name	Description	Operation
Bits 15-8	cca_vt[7:0] - Threshold value for Clear Channel Assessment in dB-linear format	Default is 0x00.
Bits 7-0	power_comp[7:0] - This is a binary value that is added to the measured value of the CCA operation. The result is stored in <code>cca_final[7:0]</code>	Default is 0x8D

4.9 IRQ_Mask - Register 05

The IRQ_Mask Register 05 provides most, but not all, mask bits for various interrupt sources for the MC13192. If a mask bit is set, its associated status bit being true will generate an interrupt on the MC13192 IRQ pin. The interrupt is cleared when the status bit is read via a SPI transaction.

		Register 05										0x05					
BIT		15	14	13	12	11	10	9	8	7	6	5	4	3	2	1	0
		attn_mask			ram_addr_mask	arb_busy_mask	strm_data_mask	pll_lock_mask	acom_en				doze_mask	tmr4_mask	tmr3_mask	tmr2_mask	tmr1_mask
TYPE		r/w			r/w	r/w	r/w	r/w	r/w				r/w	r/w	r/w	r/w	r/w
RESET		1	0	0	0	0	0	0	0	0	1	0	0	0	0	0	0
		0x8040															

Table 4-8. Register 05 Description

Name	Description	Operation
Bits 14-13, 7-5	Reserved	Leave default
Bit 15	attn_mask — The attention interrupt mask bit controls the attn_irq interrupt on the IRQ pin. Default is for the interrupt to be enabled out of reset.	1 = Allows attn_irq to generate an interrupt on the IRQ pin. 0 = When attn_irq status bit is set, IRQ pin is not asserted.
Bit 12	ram_addr_mask — The Packet RAM address error interrupt mask bit controls the ram_addr_err interrupt on the IRQ pin.	1 = Allows ram_addr_err to generate an interrupt on the IRQ. 0 = When ram_addr_err status bit is set, IRQ pin is not asserted.
Bit 11	arb_busy_mask — The Packet RAM arbiter busy error interrupt mask bit controls the arb_busy_err interrupt on the IRQ pin.	1 = Allows arb_busy_err to generate an interrupt on the IRQ pin. 0 = When arb_busy_err status bit is set, IRQ pin is not asserted.
Bit 10	strm_data_mask — The Stream Mode data error interrupt mask bit controls the strm_data_irq interrupt on the IRQ pin.	1 = Allows strm_data_err to generate an interrupt on the IRQ pin. 0 = When strm_data_err status bit is set, IRQ pin is not asserted.
Bit 9	pll_lock_mask — The LO1 unlock detect mask bit controls the pll_lock_irq interrupt on the IRQ pin.	1 = Allows pll_lock_irq to generate an interrupt on the IRQ pin. 0 = When pll_lock_irq status bit is set, IRQ pin is not asserted.

Table 4-8. Register 05 Description (continued)

Name	Description	Operation
Bit 8	acoma_en — The Acoma Mode enable bit controls Doze Mode. Acoma is an enhanced power save mode within Doze.	1 = The MC13192 stays in Doze until <u>ATTN</u> asserted. Event Timer and Prescaler clocks disabled for additional current savings. 0 = Normal operation. Doze is exited by TC2 match or <u>ATTN</u> assertion.
Bit 4	doze_mask — The Doze timer interrupt mask bit controls the doze_irq interrupt on the IRQ pin.	1 = Allows doze_irq to generate an interrupt on the IRQ pin. 0 = When doze_irq status bit is set, IRQ pin is not asserted.
Bit 3	tmr4_mask — The Event Timer four interrupt mask bit controls the tmr4_irq interrupt on the IRQ pin.	1 = Allows tmr4_irq to generate an interrupt on the IRQ pin. 0 = When tmr4_irq status bit is set, IRQ pin is not asserted.
Bit 2	tmr3_mask — The Event Timer three interrupt mask bit controls the tmr3_irq interrupt on the IRQ pin.	1 = Allows tmr3_irq to generate an interrupt on the IRQ pin. 0 = When tmr3_irq status bit is set, IRQ pin is not asserted.
Bit 1	tmr2_mask — The Event Timer two interrupt mask bit controls the tmr2_irq interrupt on the IRQ pin.	1 = Allows tmr2_irq to generate an interrupt on the IRQ pin. 0 = When tmr2_irq status bit is set, IRQ pin is not asserted.
Bit 0	tmr1_mask — The Event Timer one interrupt mask bit controls the tmr1_irq interrupt on the IRQ pin.	1 = Allows tmr1_irq to generate an interrupt on the IRQ pin. 0 = When tmr1_irq status bit is set, IRQ pin is not asserted.

4.10 Control_A - Register 06

The Control_A Register 06 is one of several registers that provide control fields for the MC13192.

		Register 06											0x06				
BIT		15	14	13	12	11	10	9	8	7	6	5	4	3	2	1	0
					tx_strm	rx_strm	cca_mask	tx_sent_mask	rx_rcvd_mask	tmr_trig_en		cca_type[1:0]					xcvr_seq
TYPE					r/w	r/w	r/w	r/w	r/w	r/w			r/w				r/w
RESET		0	0	0	0	0	0	0	0	0	0	0	1	0	0	0	0
		0x0010															

Table 4-9. Register 06 Description

Name	Description	Operation
Bits 15-13, 6,3,2	Reserved	Leave default
Bit 12	tx_strm — The transmit Stream Mode bit enables transmit streaming data transfer mode	1 = Real-time streaming of TX data to transceiver via SPI bus and IRQ on word-by-word basis. 0 = TX Packet Mode with data preloaded in TX RAM
Bit 11	rx_strm — The receive Stream Mode bit enables receive streaming data transfer mode	1 = Real-time streaming of RX data from transceiver via SPI bus and IRQ on word-by-word basis. 0 = RX Packet Mode with data preloaded in RX RAM
Bit 10	cca_mask — The CCA interrupt mask bit controls the cca_irq interrupt on the IRQ pin.	1 = Allows the cca_irq to generate an interrupt on the IRQ pin. 0 = When icca_irq status bit is set, IRQ pin is not asserted.
Bit 9	tx_sent_mask — The transmit sent mask bit controls the tx_sent_irq interrupt on the IRQ pin.	1 = Allows the tx_sent_irq to generate an interrupt on the IRQ pin. 0 = When tx_sent_irq status bit is set, IRQ pin is not asserted.
Bit 8	rx_rcvd_mask — The packet received interrupt mask bit controls the rx_rcvd_irq interrupt on the IRQ pin.	1 = Allows rx_rcvd_irq to generate an interrupt on the IRQ pin. 0 = When rx_rcvd_irq status bit is set, IRQ pin is not asserted.
Bit 7	tmr_trig_en — The timer trigger enable bit determines whether transceiver operation is initiated via Timer Comparator 2 or manually.	1 = The selected transceiver operation is initiated via Timer Comparator 2, or TC2_Prime. 0 = The selected transceiver operation is initiated manually via the RXTXEN pin and by SPI programming.

Table 4-9. Register 06 Description (continued)

Name	Description	Operation
Bits 5-4	cca_type[1:0] — The clear channel assessment type bits selects one of two possible CCA functions. Algorithm results are reported in field <code>cca_final[7:0]</code> , RX_Status Register 2D, Bits 15 - 8.	01 = clear channel assessment 10 = energy detection
Bits 1-0	xcvr_seq[1:0] — The transceiver operation bits select one of four possible transceiver modes.	00 = Idle (default) 01 = CCA /energy detection 10 = Packet Mode RX 11 = Packet Mode TX

Use Not Recommended for New Designs.
MC1320X.

4.11 Control_B - Register 07

The Control_B Register 07 is one of several registers that provide control fields for the MC13192.

		Register 07										0x07					
BIT		15	14	13	12	11	10	9	8	7	6	5	4	3	2	1	0
		tmr_load				miso_hiz_en		clko_doze_en		tx_done_mask	rx_done_mask	use_strm_mode				hib_en	doze_en
TYPE		r/w				r/w		r/w		r/w	r/w	r/w				r/w	r/w
RESET		0	0	0	0	1	1	0	0	0	0	0	0	0	0	0	0
		0x0C00															

Table 4-10. Register 07 Description

Name	Description	Operation
Bits 14-12, 10, 8, 4-2	Reserved	Leave default
Bit 15	tmr_load — The load Event Timer bit, when programmed from low to high, causes the value of the SPI field <code>tmr_cmp1[23:0]</code> to be loaded into the Event Timer.	Write from 0 to 1 to affect load. Rewrite to 0, before writing another 1 to affect another load.
Bit 11	miso_hiz_en — The MISO high impedance enable bit either tristates or drives the MISO pin to a logic low when \overline{CE} is negated.	1 = MISO pin is tristated when \overline{CE} is negated (default) 0 = MISO pin is driven to a logic low when \overline{CE} is negated. It is recommended to program miso_hiz_en = 0 for low power modes.
Bit 9	clko_doze_en — The CLKO enable in Doze Mode bit controls toggling of the CLKO pin during Doze Mode.	1 = The CLKO pin continues to toggle at selected rate during Doze Mode if CLKO is enabled (<code>clko_en</code> = 1). 0 = The CLKO pin stops toggling 128 xtal or reference cycles after the doze_en bit is programmed to 1. Note: In Doze Mode only, CLKO frequencies of 1.0 MHz or less are available.
Bit 7	tx_done_mask — The Stream Mode transmit done interrupt mask bit controls the <code>tx_done_irq</code> interrupt.	1 = Allows the <code>tx_done_irq</code> to generate an interrupt on the IRQ pin. 0 = The <code>tx_done_irq</code> status bit is set, but IRQ pin is not asserted. Note: <code>tx_done_irq</code> replaces the <code>ram_addr_err</code> when SPI bit <code>use_strm_mode</code> , Register 7, Bit 5 = 1.

Table 4-10. Register 07 Description (continued)

Name	Description	Operation
Bit 6	rx_done_mask — The Stream Mode receive done interrupt mask bit controls the rx_done_irq interrupt.	1 = Allows the rx_done_irq to generate an interrupt on the IRQ pin. 0 = The rx_done_irq status bit is set, but IRQ pin is not asserted. Note: The rx_done_irq replaces the arb_busy_err when SPI bit use_strm_mode, Register 7, Bit 5 = 1.
Bit 5	use_strm_mode — The Stream Mode select bit selects Stream Mode or Packet Mode for transmit and receive data handling.	In Packet Mode, data is stored in RAM and handled as a packet. In Stream Mode, data is managed word-by-word through the SPI. 0 = Packet Mode 1 = Stream Mode
Bit 1	hib_en — The hibernate enable bit can set the MC13192 into its lowest power saving mode without a running time base.	1 = Places the MC13192 into its lowest power operating mode without a running time base. 0 = Normal operation.
Bit 0	doze_en — The doze enable bit can set the MC13192 into its lowest power saving mode with a running time base.	1 = Places the MC13192 into its lowest power operating mode with a running time base. 0 = Normal operation.

4.12 PA_Enable - Register 08

The PA_Enable Register 08 contains the power amp (PA) enable bit which turns on and off the transmitter outputs. This feature is useful for sequences in RF test configurations. The default condition is with the transmitter enabled.

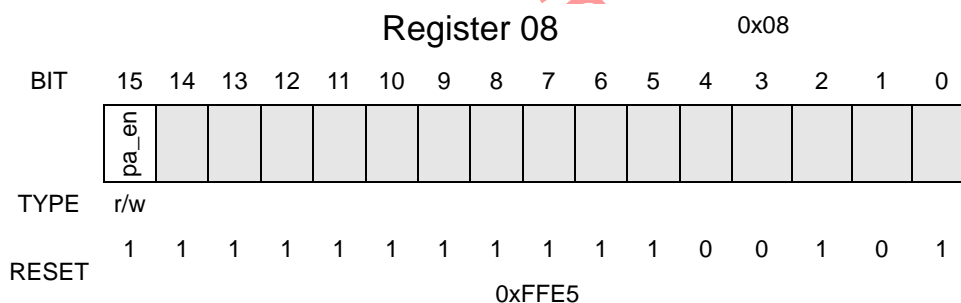

Table 4-11. Register 08 Description

Name	Description	Operation
Bits 14-0	Reserved	
Bit 15	pa_en — The power amp (PA) enable bit controls the transmitter PA outputs.	1 = PA enabled. 0 = PA disabled; the transmitter puts out no power.

4.13 Control_C - Register 09

The Control_C Register 09 is one of several registers that provide control fields for the MC13192.

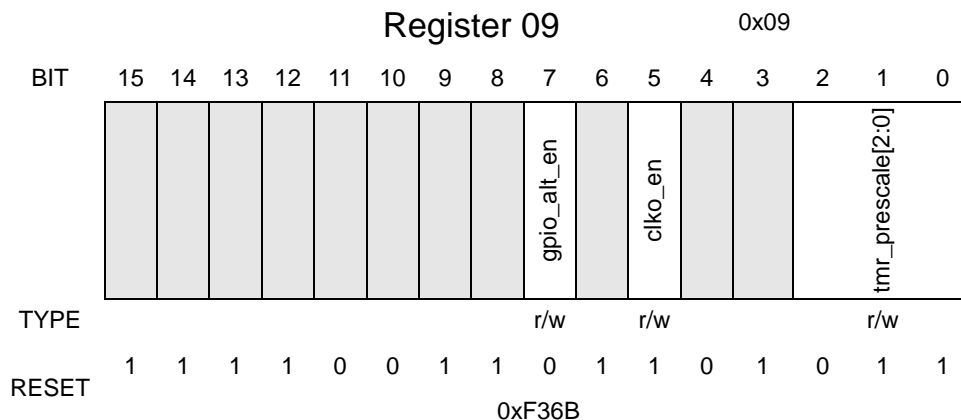

Table 4-12. Register 09 Description

Name	Description	Operation
Bits 15-8, 6, 4, 3	Reserved	Leave default
Bit 7	gpio_alt_en — The GPIO alternative MCU interface enable bit controls GPIO1 and GPIO2.	1 = GPIO1 and GPIO2 are used as status to the MCU. GPIO1 indicates when the MC13192 is out of idle. GPIO2 indicates a valid CRC or CCA result. These signals are required for Freescale's 802.15.4 Standard MAC software. 0 = Normal GPIO operation.
Bit 5	clko_en — This bit enables the clock output which can be used as a reference clock for the MCU. Frequency is dependent on the value of clko_rate[2:0] (Register 0A, Bits 2 - 0).	1 = Output enabled (default). 0 = Output low
Bits 2-0	tmr_prescale[2:0] — The Event Timer prescale value bits select the frequency of the base clock for the Event Timer module.	See Section 7.1 for more information.

4.14 CLKO_Ctl - Register 0A

The MC13192 provides the ability to trim the crystal oscillator frequency and an output clock with a programmable frequency that can be used to drive another device, such as a microcontroller. The field `xtal_trim[7:0]`, CLKO_Ctl Register 0A, Bits 15-8, alter the capacitive loading to the crystal and affects the oscillator frequency. See [Section 9.3.2](#).

The CLKO frequency is programmed using `clko_rate[2:0]`, CLKO_Ctl Register 0A, Bits 2-0. [Table 4-13](#) lists each setting and its respective frequency.

Table 4-13. CLKO Frequency

clko_rate	CLKO
000	16 MHz
001	8 MHz
010	4 MHz
011	2 MHz
100	1 MHz
101	62.5 kHz
110 (default)	32.786+ kHz = 16 MHz / 488
111	16.393+ kHz = 16 MHz / 976

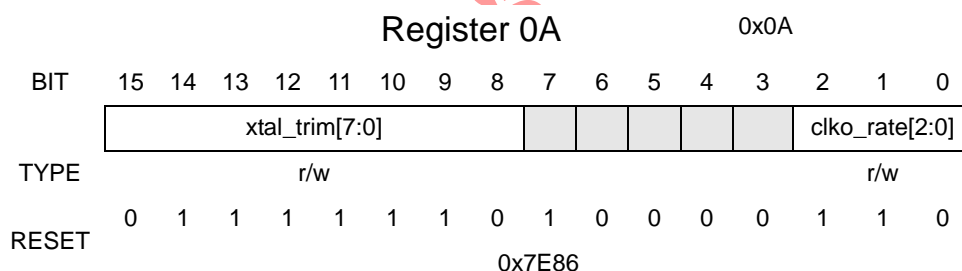

Table 4-14. Register 0A Description

Name	Description	Operation
Bits 7-3	Reserved	Leave default
Bits 15-8	xtal_trim[7:0] — The crystal oscillator capacitor trim bits warps the crystal frequency by approximately -0.25 ppm per bit.	0x7E is the default setting and suggested start point for trimming.
Bits 2-0	clko_rate[2:0] — The CLKO rate bits select the clock frequency of the CLKO pin.	See Table 4-13 .

4.15 GPIO_Dir - Register 0B

The GPIO_Dir Register 0B contains control bits for GPIO1 through GPIO7 that configure the data direction of each GPIO as well as a control field that sets the output drive strength of GPIO1 through GPIO4. Each GPIO bit has a corresponding bit to set the GPIO as an output and a separate corresponding bit to set the GPIO as an input. If both enable bits are set simultaneously for a given GPIO, the GPIO is configured as an input (input setting wins). During a hardware reset on RST, all the GPIO are tristated and the GPIO default to inputs.

		Register 0B											0x0B						
BIT		15	14	13	12	11	10	9	8	7	6	5	4	3	2	1	0		
		gpio1234_drv[1:0]				gpio7_oen	gpio6_oen	gpio5_oen	gpio4_oen	gpio3_oen	gpio2_oen	gpio1_oen	gpio7_ien	gpio6_ien	gpio5_ien	gpio4_ien	gpio3_ien	gpio2_ien	gpio1_ien
TYPE		r/w	r/w	r/w	r/w	r/w	r/w	r/w	r/w	r/w	r/w	r/w	r/w	r/w	r/w	r/w	r/w	r/w	
RESET		0	0	0	0	0	0	0	0	0	0	1	1	1	1	1	1	1	
		0x007F																	

Table 4-15. Register 0B Description

Name	Description	Operation
Bits 15-14	gpio1234_drv[1:0] — These bits select output drive strength for GPIO1 through GPIO4.	00 (default) = lowest drive strength; 11 = highest drive strength.
Bit 13	gpio7_oen — This bit configures GPIO7 as an output.	1 = GPIO7 enabled as output. 0 = GPIO7 disabled as output.
Bit 12	gpio6_oen — This bit configures GPIO6 as an output.	1 = GPIO6 enabled as output. 0 = GPIO6 disabled as output.
Bit 11	gpio5_oen — This bit configures GPIO5 as an output.	1 = GPIO5 enabled as output. 0 = GPIO5 disabled as output.
Bit 10	gpio4_oen — This bit configures GPIO4 as an output.	1 = GPIO4 enabled as output. 0 = GPIO4 disabled as output.
Bit 9	gpio3_oen — This bit configures GPIO3 as an output.	1 = GPIO3 enabled as output. 0 = GPIO3 disabled as output.
Bit 8	gpio2_oen — This bit configures GPIO2 as an output.	1 = GPIO2 enabled as output. 0 = GPIO2 disabled as output.
Bit 7	gpio1_oen — This bit configures GPIO1 as an output.	1 = GPIO1 enabled as output. 0 = GPIO1 disabled as output.
Bit 6	gpio7_ien — This bit configures GPIO7 as an input.	1 = GPIO7 enabled as input. 0 = GPIO7 disabled as input.
Bit 5	gpio6_ien — This bit configures GPIO6 as an input.	1 = GPIO6 enabled as input. 0 = GPIO6 disabled as input.

Table 4-15. Register 0B Description (continued)

Name	Description	Operation
Bit 4	gpio5_ien — This bit configures GPIO5 as an input.	1 = GPIO5 enabled as input. 0 = GPIO5 disabled as input.
Bit 3	gpio4_ien — This bit configures GPIO4 as an input.	1 = GPIO4 enabled as input. 0 = GPIO4 disabled as input.
Bit 2	gpio3_ien — This bit configures GPIO3 as an input.	1 = GPIO3 enabled as input. 0 = GPIO3 disabled as input.
Bit 1	gpio2_ien — This bit configures GPIO2 as an input.	1 = GPIO2 enabled as input. 0 = GPIO2 disabled as input.
Bit 0	gpio1_ien — This bit configures GPIO1 as an input.	1 = GPIO1 enabled as input. 0 = GPIO1 disabled as input.

Not Recommended for New Designs.
 MC1320X.

4.16 GPIO_Data_Out - Register 0C

The GPIO_Data_Out Register 0C contains a bit for each GPIO that sets its output value if the GPIO is configured as an output as well as a control fields that set the output drive strength of GPIO5 through GPIO7, MISO, CLKO, and $\overline{\text{IRQ}}$. This register also contains the pullup enable for the $\overline{\text{IRQ}}$ pin.

		Register 0C											0x0C				
BIT		15	14	13	12	11	10	9	8	7	6	5	4	3	2	1	0
		gpio567_drv[1:0]		miso_drv[1:0]		clko_drv[1:0]		irqb_drv[1:0]		irqb_pup_en	gpio7_o	gpio6_o	gpio5_o	gpio4_o	gpio3_o	gpio2_o	gpio1_o
TYPE		r/w	r/w	r/w	r/w	r/w	r/w	r/w	r/w	r/w	r/w	r/w	r/w	r/w	r/w	r/w	r/w
RESET		0	0	0	0	0	0	1	1	1	0	0	0	0	0	0	0
0x0380																	

Table 4-16. Register 0C Description

Name	Description	Operation
Bits 15-14	gpio567_drv[1:0] — These bits select output drive strength for GPIO5 through GPIO7.	00 (default) = lowest drive strength; 11 = highest drive strength.
Bits 13-12	miso_drv[1:0] - These bits select output drive strength for signal MISO.	00 (default) = lowest drive strength; 11 = highest drive strength.
Bits 11-10	clko_drv[1:0] - These bits select output drive strength for signal CLKO.	00 (default) = lowest drive strength; 11 = highest drive strength.
Bits 9-8	irqb_drv[1:0] - These bits select output drive strength for signal $\overline{\text{IRQ}}$.	00 = lowest drive strength; 11 (default) = highest drive strength.
Bit 7	irqb_pup_en — $\overline{\text{IRQ}}$ pullup enable.	1 = Onboard pullup enabled (nominal 40 k Ω) on $\overline{\text{IRQ}}$ pin (default) 0 = Open drain only (external pullup required).
Bit 6	gpio7_o — GPIO7 output value.	1 = GPIO7 driven high 0 = GPIO7 driven low
Bit 5	gpio6_o — GPIO6 output value.	1 = GPIO6 driven high 0 = GPIO6 driven low
Bit 4	gpio5_o — GPIO5 output value.	1 = GPIO5 driven high 0 = GPIO5 driven low
Bit 3	gpio4_o — GPIO4 output value.	1 = GPIO4 driven high 0 = GPIO4 driven low
Bit 2	gpio3_o — GPIO3 output value.	1 = GPIO3 driven high 0 = GPIO3 driven low

Table 4-16. Register 0C Description (continued)

Name	Description	Operation
Bit 1	gpio2_o — GPIO2 output value.	1 = GPIO2 driven high 0 = GPIO2 driven low
Bit 0	gpio1_o — GPIO1 output value.	1 = GPIO1 driven high 0 = GPIO1 driven low

4.17 LO1_Int_Div - Register 0F

The LO1_Int_Div Register 0F contains the 8-bit integer divide value for the LO1 fractional-N synthesizer that sets transceiver channel frequency. See [Table 4-19](#).

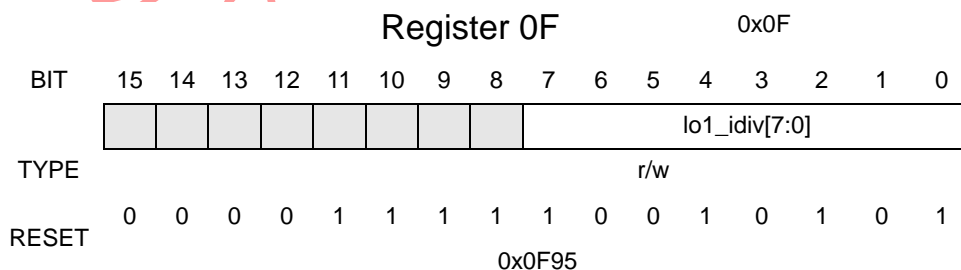

Table 4-17. Register 0F Description

Name	Description	Operation
Bits 15-8	Reserved.	Leave default.
Bits 7-0	lo1_idiv[7:0] — The LO1 integer divide bits represent the integer divide value for the LO1 fractional-N synthesizer.	Default is 149dec (0x95). See Table 4-19 .

4.18 LO1_Num - Register 10

The LO1_Num Register 10 contains the 16-bit integer numerator value for the LO1 fractional-N synthesizer that sets transceiver channel frequency. See [Table 4-19](#).

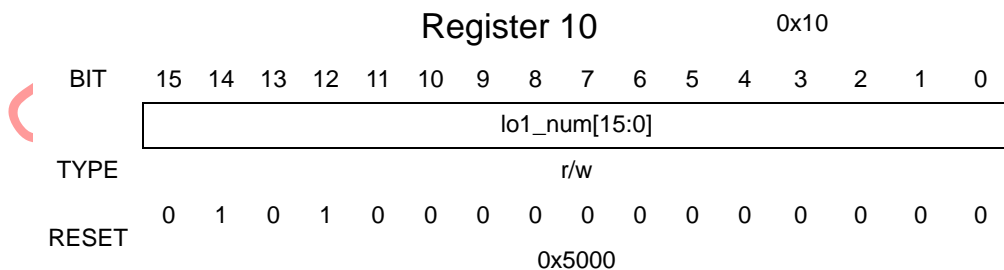

Table 4-18. Register 10 Description

Name	Description	Operation
Bits 15-0	lo1_num[15:0] — These bits represent the numerator of the fractional divide value for the LO1 fractional-N synthesizer.	Default is 20,480dec (0x5000). See Table 4-19 .

Table 4-19. Channel Operation

Channel (Dec)	802.15.4 Channel Number	Frequency (MHz)	Integer Setting lo1_idiv[7:0] (Dec / Hex)	Fractional Setting lo1_num[15:0] (Dec / Hex)
1	11	2405	149 / 0x95 (default)	20480 / 0x5000 (default)
2	12	2410	149 / 0x95	40960 / 0xA000
3	13	2415	149 / 0x95	61440 / 0xF000
4	14	2420	150 / 0x96	16384 / 0x4000
5	15	2425	150 / 0x96	36864 / 0x9000
6	16	2430	150 / 0x96	57344 / 0xE000
7	17	2435	151 / 0x97	12288 / 0x3000
8	18	2440	151 / 0x97	32768 / 0x8000
9	19	2445	151 / 0x97	53248 / 0xD000
10	20	2450	152 / 0x98	8192 / 0x2000
11	21	2455	152 / 0x98	28672 / 0x7000
12	22	2460	152 / 0x98	49152 / 0xC000
13	23	2465	153 / 0x99	4096 / 0x1000
14	24	2470	153 / 0x99	24576 / 0x6000
15	25	2475	153 / 0x99	45056 / 0xB000
16	26	2480	154 / 0x9A	0 / 0x0000

4.19 PA_Lvl - Register 12

The PA_Lvl Register 12 sets the power level and drive level of the transmitter power amplifier. See [Table 6-3](#) for power level versus field settings.

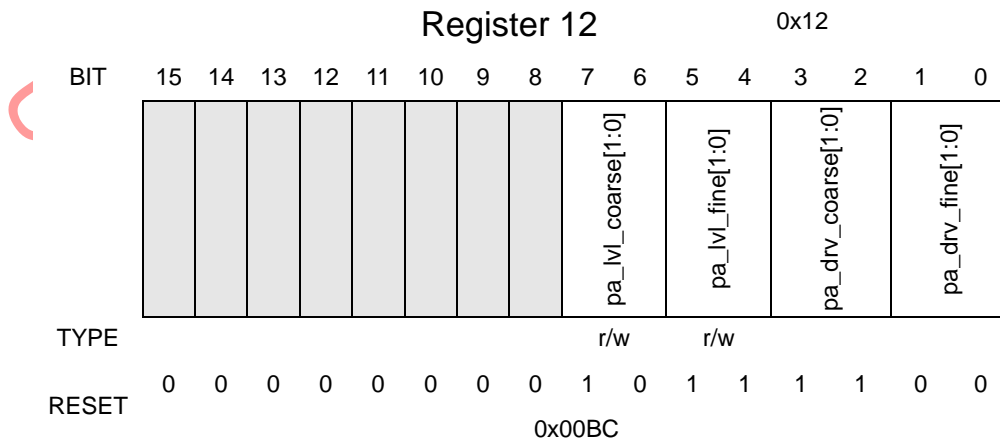

Table 4-20. Register 12 Description

Name	Description	Operation
Bits 15-8	Reserved	Leave default
Bits 7-6	pa_lvl_coarse[1:0] - These bits select the coarse PA power level adjustment.	See Section 6.5 for more information.
Bits 5-4	pa_lvl_fine[1:0] - These bits selects fine PA power level adjustment.	See Section 6.5 for more information.
Bits 3-2	pa_drv_coarse[1:0] - These bits select the coarse PA drive level adjustment.	Leave default
Bits 1-0	pa_drv_fine[1:0] - These bits select the fine PA drive level adjustment	Leave default

4.20 Tmr_Cmp1_A - Register 1B

The Tmr_Cmp1_A Register 1B contains the disable bit for Timer Comparator 1 and stores the most significant 8 bits of the 24-bit compare value (the lower 16 bits of the compare value are stored in Tmr_CMP1_B Register 1C). With regard to using the timer comparator:

- It is suggested that the timer be disabled (writing tmr_cmp1_dis to 1) during system initialization as the default mode out of reset is timer enabled.
- The value in Register 1B will not be loaded in the comparator and the affect of the timer disable bit will not active until Register 1C is written. The 24-bit comparator value must be loaded into the comparator register in parallel, and as a result, the load is caused by a write Register 1C.
- Writing of Registers 1B and 1C can be done as a recursive SPI register write transaction or two separate singular transactions. Writing to Register 1C as a separate operation will always use the present value of Register 1B to load the comparator value and set the state of the disable bit.

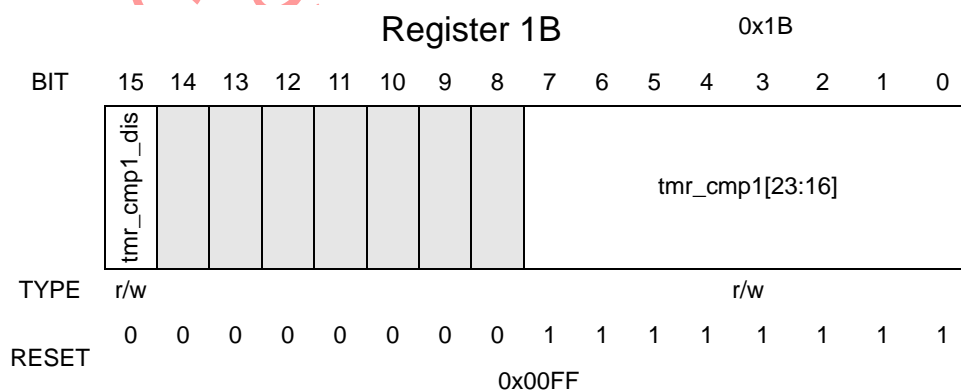

Table 4-21. Register 1B Description

Name	Description	Operation
Bits 14-8	Reserved	Leave default
Bit 15	tmr_cmp1_dis — This bit disables the Event Timer Comparator 1 function.	1 = Disables the Event Timer Compare 1 function. 0 = Enables the Event Timer Compare 1 function (default).
Bits 7-0	tmr_cmp1[23:16] — These bits represent the 8 most significant bits of 24-bit Event Timer 1 absolute time compare value, tmr_cmp1[23:0].	Default is 0xFF.

4.21 Tmr_Cmp1_B - Register 1C

The Tmr_CMP1_B Register 1C stores the least significant 16 bits of the 24-bit compare value. Writing to Register 1C causes an internal load of the full 24-bit comparator value (see [Section 4.20, “Tmr_Cmp1_A - Register 1B”](#)) and activates the mode presently set into the tmr_cmp1_dis control bit.

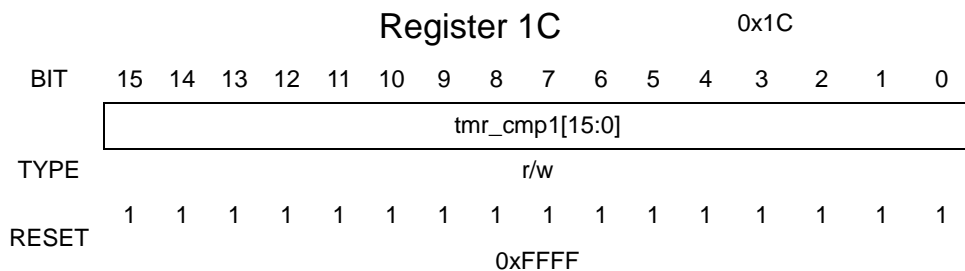

Table 4-22. Register 1C Description

Name	Description	Operation
Bits 15-0	tmr_cmp1[15:0] — These bits represent the 16 least significant bits of 24-bit Event Timer 1 absolute time compare value, tmr_cmp1[23:0].	Default is 0xFFFF.

Not Recommended for New Designs.

4.22 Tmr_Cmp2_A - Register 1D

The Tmr_Cmp2_A Register 1D contains the disable bit for Timer Comparator 2 and stores the most significant 8 bits of the 24-bit compare value (the lower 16 bits of the compare value are stored in Tmr_CMP2_B Register 1E). With regard to using the timer comparator:

- It is suggested that the timer be disabled (writing tmr_cmp2_dis to 1) during system initialization as the default mode out of reset is timer enabled.
- The value in Register 1D will not be loaded in the comparator and the affect of the timer disable bit will not active until Register 1E is written. The 24-bit comparator value must be loaded into the comparator register in parallel, and as a result, the load is caused by a write Register 1E.
- Writing of Registers 1D and 1E can be done as a recursive SPI register write transaction or two separate singular transactions. Writing to Register 1E as a separate operation will always use the present value of Register 1D to load the comparator value and set the state of the disable bit.

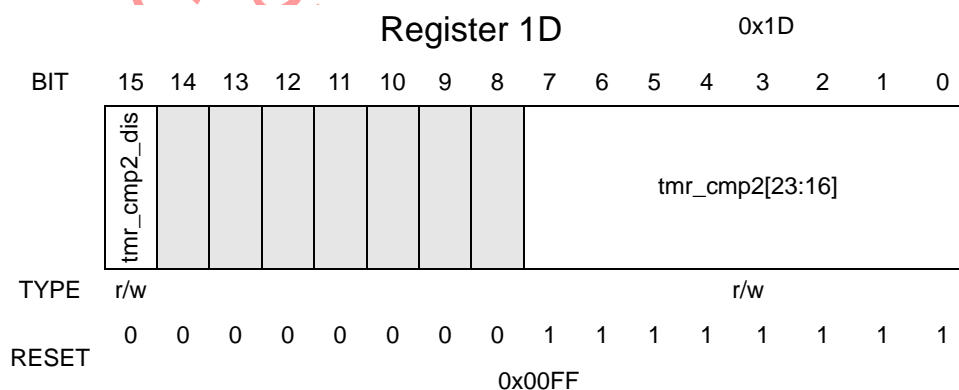

Table 4-23. Register 1D Description

Name	Description	Operation
Bits 14-8	Reserved	Leave default
Bit 15	tmr_cmp2_dis — This bit disables the Event Timer Comparator 2.	1 = Disables the Event Timer Compare 2 function. 0 = Enables the Event Timer Compare 2 function (default).
Bits 7-0	tmr_cmp2[23:16] — These bits represent the 8 most significant bits of 24-bit Event Timer 2 absolute time compare value, tmr_cmp2[23:0].	Default is 0xFF.

4.23 Tmr_Cmp2_B - Register 1E

The Tmr_CMP2_B Register 1E stores the least significant 16 bits of the 24-bit compare value. Writing to Register 1E causes an internal load of the full 24-bit comparator value (see [Section 4.22, “Tmr_Cmp2_A - Register 1D](#)) and activates the mode presently set into the tmr_cmp2_dis control bit.

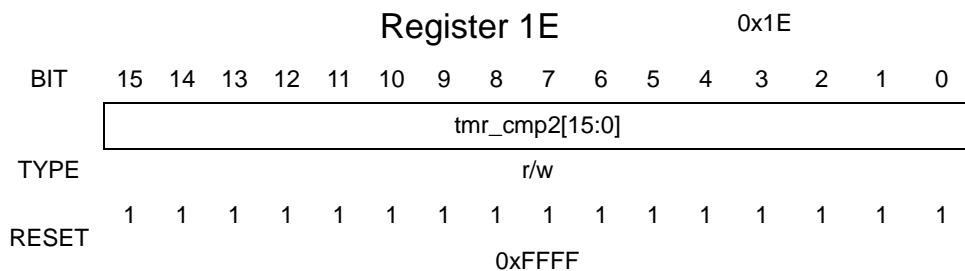

Table 4-24. Register 1E Description

Name	Description	Operation
Bits 15-0	tmr_cmp2[15:0] — These bits represent the 16 least significant bits of 24-bit Event Timer 2 absolute time compare value, tmr_cmp2[23:0].	Default is 0xFFFF.

Reserved. Recommended for New Designs.

4.24 Tmr_Cmp3_A - Register 1F

The Tmr_Cmp3_A Register 1F contains the disable bit for Timer Comparator 3 and stores the most significant 8 bits of the 24-bit compare value (the lower 16 bits of the compare value are stored in Tmr_CMP3_B Register 20). With regard to using the timer comparator:

- It is suggested that the timer be disabled (writing tmr_cmp3_dis to 1) during system initialization as the default mode out of reset is timer enabled.
- The value in Register 1F will not be loaded in the comparator and the affect of the timer disable bit will not active until Register 20 is written. The 24-bit comparator value must be loaded into the comparator register in parallel, and as a result, the load is caused by a write Register 20.
- Writing of Registers 1F and 20 can be done as a recursive SPI register write transaction or two separate singular transactions. Writing to Register 20 as a separate operation will always use the present value of Register 1F to load the comparator value and set the state of the disable bit.

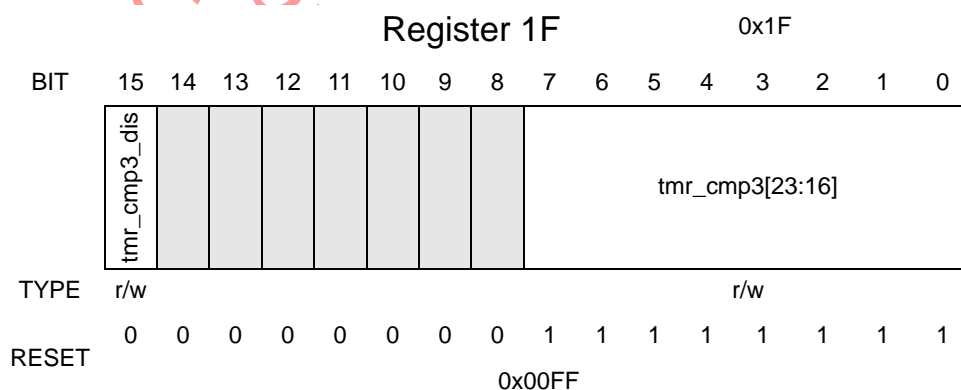

Table 4-25. Register 1F Description

Name	Description	Operation
Bits 14-8	Reserved	Leave default
Bit 15	tmr_cmp3_dis — This bit disables the Event Timer Comparator 3 interrupt and status bit.	1 = Disables Event Timer Compare 3 function. 0 = Enables Event Timer Compare 3 function (default).
Bits 7-0	tmr_cmp3[23:16] — These bits represent the 8 most significant bits of 24-bit Event Timer 3 absolute time compare value, tmr_cmp3[23:0].	Default is 0xFF.

4.25 Tmr_Cmp3_B - Register 20

The Tmr_CMP3_B Register 20 stores the least significant 16 bits of the 24-bit compare value. Writing to Register 20 causes an internal load of the full 24-bit comparator value (see [Section 4.24, “Tmr_Cmp3_A - Register 1F”](#)) and activates the mode presently set into the tmr_cmp3_dis control bit.

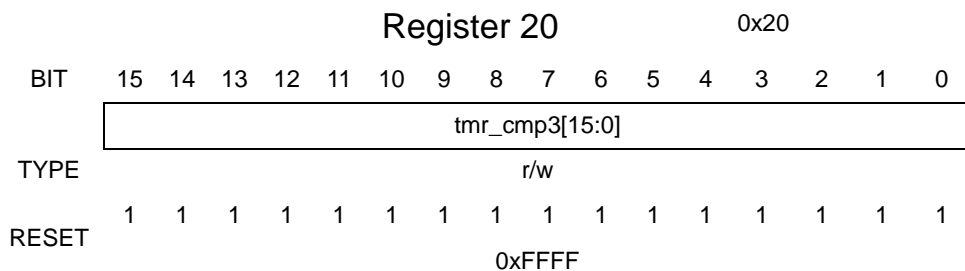

Table 4-26. Register 20 Description

Name	Description	Operation
Bits 15-0	tmr_cmp3[15:0] — These bits represent the 16 least significant bits of 24-bit Event Timer 3 absolute time compare value, tmr_cmp3[23:0].	Default is 0xFFFF.

Case Recommended for New Designs. MC1320x.

4.26 Tmr_Cmp4_A -Register 21

The Tmr_Cmp4_A Register 21 contains the disable bit for Timer Comparator 4 and stores the most significant 8 bits of the 24-bit compare value (the lower 16 bits of the compare value are stored in Tmr_CMP4_B Register 22). With regard to using the timer comparator:

- It is suggested that the timer be disabled (writing `tmr_cmp4_dis` to 1) during system initialization as the default mode out of reset is timer enabled.
- The value in Register 21 will not be loaded in the comparator and the affect of the timer disable bit will not active until Register 22 is written. The 24-bit comparator value must be loaded into the comparator register in parallel, and as a result, the load is caused by a write Register 22.
- Writing of Registers 21 and 22 can be done as a recursive SPI register write transaction or two separate singular transactions. Writing to Register 22 as a separate operation will always use the present value of Register 21 to load the comparator value and set the state of the disable bit.

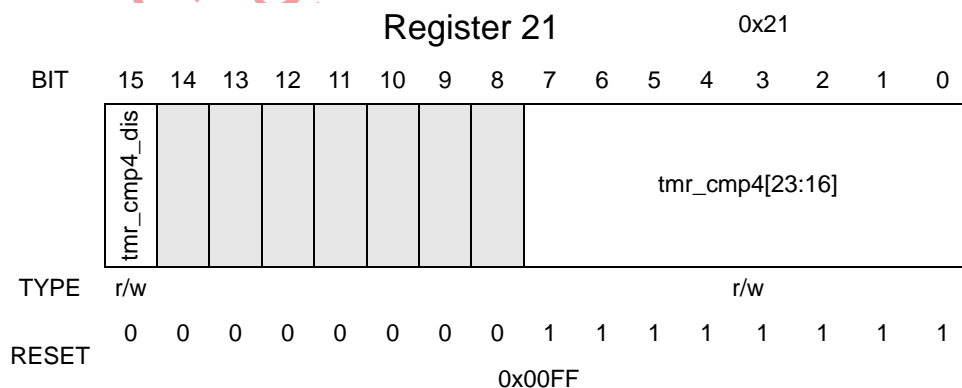

Table 4-27. Register 21 Description

Name	Description	Operation
Bits 14-8	Reserved	Leave default
Bit 15	<code>tmr_cmp4_dis</code> — This bit disables the Event Timer Comparator 4 interrupt and status bit.	1 = Disables Event Timer Compare 4 function. 0 = Enables Event Timer Compare 4 function (default).
Bits 7-0	<code>tmr_cmp4[23:16]</code> — These bits represent the 8 most significant bits of 24-bit Event Timer 4 absolute time compare value, <code>tmr_cmp4[23:0]</code> .	Default is 0xFF.

4.27 Tmr_Cmp4_B - Register 22

The Tmr_CMP4_B Register 22 stores the least significant 16 bits of the 24-bit compare value. Writing to Register 22 causes an internal load of the full 24-bit comparator value (see [Section 4.26, “Tmr_Cmp4_A-Register 21”](#)) and activates the mode presently set into the tmr_cmp4_dis control bit.

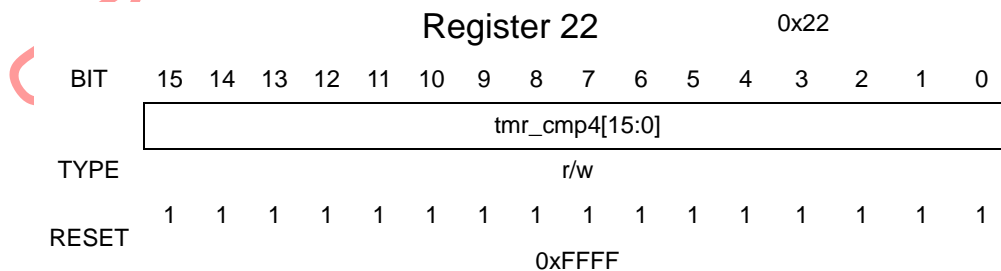

Table 4-28. Register 22 Description

Name	Description	Operation
Bits 15-0	tmr_cmp4[15:0] — These bits represent the 16 least significant bits of 24-bit Event Timer 4 absolute time compare value, tmr_cmp4[23:0].	Default is 0xFFFF.

Q130X. Recommended for New Designs.

4.28 TC2_Prime - Register 23

When the MC13192 is used in Stream Mode (Register 7, Bit 5 = 1), the 16-bit TC2_Prime Register 23 is used in place of the 24-bit Tmr_Cmp2 register(s) to initiate timer-triggered sequences. For an interrupt to be generated, tmr2_mask must be set (value = 1) and the interrupt is generated via the tmr2_irq status. Note that the tmr_cmp2_dis field should be disabled (value = 0) to use tc2_prime[15:0].

		Register 23																0x23
BIT		15	14	13	12	11	10	9	8	7	6	5	4	3	2	1	0	
		tc2_prime[15:0]																
TYPE		r/w																
RESET		1	1	1	1	1	1	1	1	1	1	1	1	1	1	1	1	
		0xFFFF																

Table 4-29. Register 23 Description

Name	Description	Operation
Bits 15-0	tc2_prime[15:0] — When use_strm_mode, Register 7, Bit 5 = 1, these bits are compared to the lower 16 bits of the Event Timer and initiate timer-triggered sequences when the value equal to current time. Note: tmr_trig_en, Register 6, Bit 7 must be set to 1. When use_strm_mode = 0, the TC2_Prime register is not used.	Default is 0xFFFF.

4.29 IRQ_Status - Register 24

The IRQ_Status Register 24 contains status bits that can, in turn, cause an interrupt request when enabled. Reading the register clears the status bits and releases an associated interrupt request on \overline{IRQ} . Note use of interrupt status Bit 14, Bit 13, Bit 7 and Bit 6 which are multiplexed and have special functionality.

		Register 24														0x24	
BIT		15	14	13	12	11	10	9	8	7	6	5	4	3	2	1	0
		pll_lock_irq	ram_addr_err	arb_busy_err	strm_data_err		attn_irq	doze_irq	tmr1_irq	rx_rcvd_irq	tx_sent_irq	cca_irq	tmr3_irq	tmr4_irq	tmr2_irq	cca	crc_valid
TYPE		r	r	r	r	r	r	r	r	r	r	r	r	r	r	r	r
RESET		0	0	0	0	0	0	0	0	0	0	0	0	0	0	0	0
		0x0000															

Table 4-30. Register 24 Description

Name	Description	Operation
Bit 11	Reserved	Leave default
Bit 15	pll_lock_irq — The Local Oscillator 1 Lock Detect Interrupt bit indicates whether the LO1 PLL is in or out of lock.	1 = LO1 PLL out of lock. Will cause an interrupt if <code>pll_lock_mask</code> is enabled. 0 = LO1 PLL is locked.
Bit 14	ram_addr_err or tx_done_irq — The Packet RAM Address Error Interrupt or Stream Mode TX Done Interrupt bit is a multiplexed interrupt status bit.	When SPI bit <code>use_strm_mode</code> , Register 7, Bit 5 = 0, Register 24, Bit 14 represents 'ram_addr_err'. <code>ram_addr_err</code> definition: a recursive SPI read or write operation to Packet RAM exceeded maximum RAM address. When SPI bit <code>use_strm_mode</code> , Register 7, Bit 5 = 1, Register 24, Bit 14 represents 'tx_done_irq'. <code>tx_done_irq</code> definition: TX Stream Mode reception complete and transceiver has returned to Idle.
Bit 13	arb_busy_err or rx_done_irq — The Packet RAM Arbiter Busy Error Interrupt or Steam Mode RX Done Interrupt bit is a multiplexed interrupt status bit.	When SPI bit <code>use_strm_mode</code> , Register 7, Bit 5 = 0, Register 24, Bit 13 represents 'arb_busy_err'. <code>arb_busy_err</code> definition: a SPI read or write operation to Packet RAM attempted during packet reception or transmission, respectively. When SPI bit <code>use_strm_mode</code> , Register 7, Bit 5 = 1, Register 24, Bit 13 represents 'rx_done_irq'. <code>rx_done_irq</code> definition: RX Stream Mode reception complete and transceiver has returned to Idle Mode.
Bit 12	strm_data_err — The Stream Mode Data Error Interrupt bit indicates Stream Mode data read or write error	For RX Stream Mode, this bit gets set if a new RX word is updated to the SPI before the previous word is read. For TX Stream Mode, the current TX word transmission is complete prior to next TX word being written to SPI.

Table 4-30. Register 24 Description (continued)

Name	Description	Operation
Bit 10	attn_irq — The Attention Interrupt bit indicates the ATTN pin has been asserted or Power-up complete condition from a reset condition.	The bit being set indicates the $\overline{\text{ATTN}}$ signal has been asserted low or that the MC13192 has reached a Power-up complete condition after software reset (CE released) or a hardware reset ($\overline{\text{RST}}$ released).
Bit 9	doze_irq — The Doze Timer Interrupt bit.	This bit gets set when the 'tmr_cmp2[23:0]' field matches the current Event Timer value while in Doze Mode. The MC13192 returns to Idle state from Doze Mode.
Bit 8	tmr1_irq — The Timer Compare 1 Interrupt bit.	This bit gets set when the 'tmr_cmp1[23:0]' field matches the current Event Timer value.
Bit 7	rx_rcvd_irq or rx_strm_irq — The RX Packet Received Interrupt or RX Stream Data Ready Interrupt bit is a multiplexed interrupt status bit	When SPI bit use_strm_mode, Register 7, Bit 5 = 0, Register 24, Bit 7 represents 'rx_rcvd_irq'. rx_rcvd_irq definition: RX Packet Mode reception complete and transceiver has returned to Idle Mode. When SPI bit use_strm_mode, Register 7, Bit 5 = 1, Register 24, Bit 7 represents 'rx_strm_irq'. rx_strm_irq definition: 1) First occurrence - RX Packet Length is available to be read. 2) Subsequent occurrences - next receive Stream data word is ready to be read.
Bit 6	tx_sent_irq or tx_strm_irq — The TX Packet Sent Interrupt or TX Stream Data Needed Interrupt bit is a multiplexed interrupt status bit.	When SPI bit use_strm_mode, Register 7, Bit 5 = 0, Register 24, Bit 6 represents 'tx_sent_irq'. tx_sent_irq definition: TX Packet Mode operation complete and transceiver has returned to Idle Mode. When SPI bit use_strm_mode, Register 7, Bit 5 = 1, Register 24, Bit 7 represents 'tx_strm_irq'. tx_strm_irq definition: Transceiver is ready for next Stream transmit data word to be written.
Bit 5	cca_irq — The Clear Channel Assessment Ready Interrupt bit.	This bit is set when the 'Clear Channel Assessment' operation is complete.
Bit 4	tmr3_irq — The Timer Compare 3 Interrupt bit.	This bit gets set when the 'tmr_cmp3[23:0]' field matches the current Event Timer value.
Bit 3	tmr4_irq — The Timer Compare 4 Interrupt bit.	This bit gets set when the 'tmr_cmp4[23:0]' field matches the current Event Timer value.
Bit 2	tmr2_irq — The Timer Compare 2 Interrupt bit.	This bit gets set when the 'tmr_cmp2[23:0]' field matches the current Event Timer value, or alternately if 'tc2_prime[15:0]' field matches the current Event Timer[15:0] when enabled.
Bit 1	cca — The Clear Channel Assessment bit indicates channel busy or channel idle.	1 = channel busy detected 0 = channel idle detected Note: For cca_type[1:0], Register 6, Bits 5:4 = 10, Energy Detect mode, CCA is not calculated and cca is held low.
Bit 0	crc_valid — The RX CRC Result bit denotes if the CRC is correct or not.	1 = RX CRC correct 0 = RX CRC incorrect (default)

4.30 RST_Ind - Register 25

The RST_Ind Register 25 contains the reset indicator bit. Bit reset_ind is cleared during a reset and gets set if Register 25 is read after a reset and remains set. This bit is useful for the MCU to determine if the transceiver has returned from a Hibernate condition via an \overline{ATTN} signal or recovered from a reset condition.

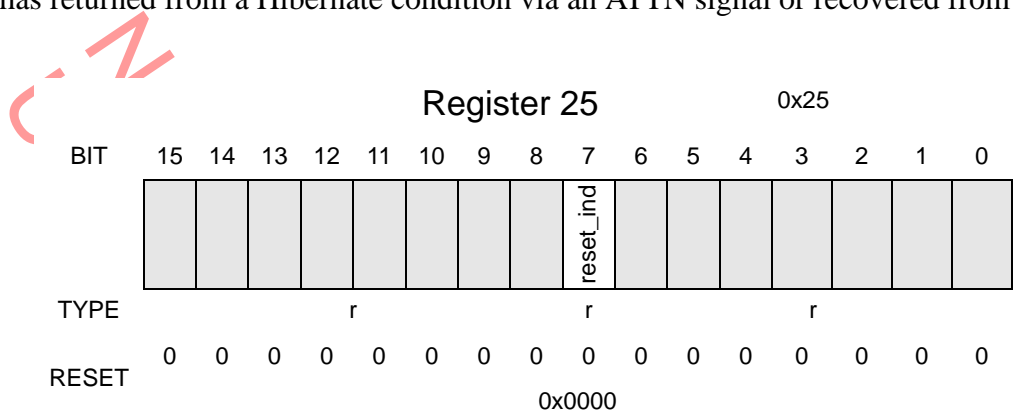

Table 4-31. Register 25 Description

Name	Description	Operation
Bits 15-8, 6-0	Reserved	
Bit 7	reset_ind — The reset indicator bit shows whether Register 25 was read since the last \overline{RST} assertion or program reset.	1 = Register 25 has been read since the last \overline{RST} or Program Reset event. 0 = Register 25 has not been read since the last \overline{RST} or Program Reset event. Note: Reading Register 25 will set Bit 7.

4.31 Current_Time_A - Register 26

The Current_Time_A Register 26 is read to get the 8 most significant bits of the current value of the 24-bit counter of the Event Timer.

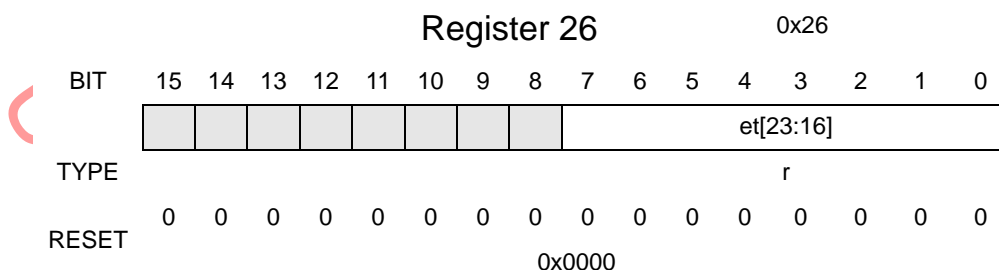

Table 4-32. Register 26 Description

Name	Description	Operation
Bits 15-8	Reserved	
Bits 7 - 0	et [23:16] — These bits are the 8 most significant bits of the current time in the Event Timer counter.	

4.32 Current_Time_B - Register 27

The Current_Time_B Register 27 is read to get the 16 least significant bits of the current value of the 24-bit counter of the Event Timer.



Table 4-33. Register 27 Description

Name	Description	Operation
Bits 15-0	et[15:0] — These bits represent the 16 least significant bits of the current time of the Event Timer counter.	

4.33 GPIO_Data_In - Register 28

The GPIO_Data_In Register 28 is read to determine the state of any GPIO that are configured as an input.

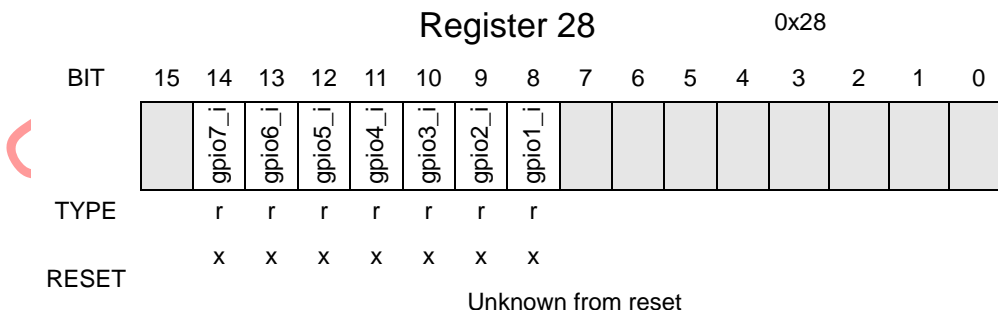

Table 4-34. Register 28 Description

Name	Description	Operation
Bits 15, 7-0	Reserved	
Bit 14	gpio7_i — This bit is the input value of GPIO7.	With gpio7_oen = 0 and gpio7_ien = 1; GPIO7 is configured as an input whose value can be read from gpio7_i.
Bit 13	gpio6_i — This bit is the input value of GPIO6.	With gpio6_oen = 0 and gpio6_ien = 1; GPIO6 is configured as an input whose value can be read from gpio6_i.
Bit 12	gpio5_i — This bit is the input value of GPIO5.	With gpio5_oen = 0 and gpio5_ien = 1; GPIO5 is configured as an input whose value can be read from gpio5_i.
Bit 11	gpio4_i — This bit is the input value of GPIO4.	With gpio4_oen = 0 and gpio4_ien = 1; GPIO4 is configured as an input whose value can be read from gpio4_i.
Bit 10	gpio3_i — This bit is the input value of GPIO3.	With gpio3_oen = 0 and gpio3_ien = 1; GPIO3 is configured as an input whose value can be read from gpio3_i.
Bit 9	gpio2_i — This bit is the input value of GPIO2.	With gpio2_oen = 0 and gpio2_ien = 1; GPIO2 is configured as an input whose value can be read from gpio2_i.
Bit 8	gpio1_i — This bit is the input value of GPIO1.	With gpio1_oen = 0 and gpio1_ien = 1; GPIO1 is configured as an input whose value can be read from gpio1_i.

4.34 Chip_ID - Register 2C

The Chip_ID Register 2C is read to get the 9-bit chip version code contained in the `chip_id[8:0]` field. The present version numbers include 0x5000 and 0x5400. Version 0x5400 is the latest version of the device.

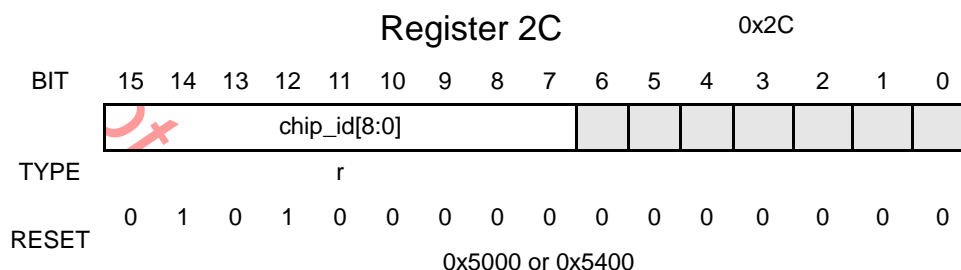

Table 4-35. Register 2C Description

Name	Description	Operation
Bits 6-0	Reserved	
Bits 15- 7	chip_id [8:0] — These bits are the 9-bit chip version code for the transceiver.	Version dependent.

4.35 RX_Status - Register 2D

The RX_Status Register 2D has two fields, the first of which represents the average results of the CCA algorithm selected by `cca_type[1:0]`, Register 6, Bits 5-4. The second field gives the receive packet length parsed from the packet header; the value is latched after an RX Start Frame Delimiter is detected.

During a RX Stream Mode sequence, loading a valid FLI in `rx_pkt_latch[6:0]` causes the first `rx_strm_irq` status and interrupt in the sequence. Reading RX_Status Register 2D for that first `rx_strm_irq` interrupt will clear the status and the interrupt. As a result, reading IRQ_Status Register 24 is not required (see [Section 6.3.4.1](#)).

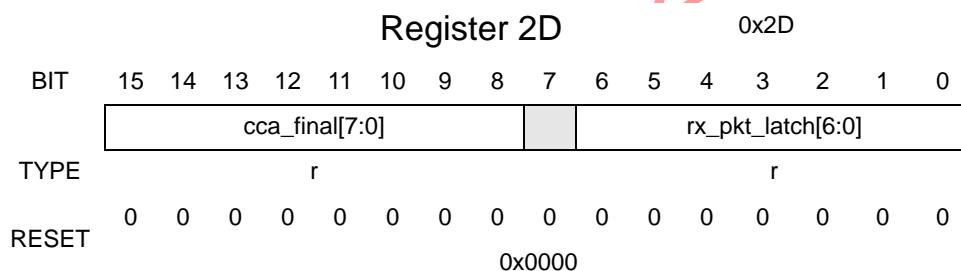

Table 4-36. Register 2D Description

Name	Description	Operation
Bit 7	Reserved	
Bits 15-8	cca_final [7:0] — Average CCA energy.	These bits represent the average result of the CCA algorithm selected by <code>cca_type[1:0]</code> , Register 6, Bits 5-4.
Bits 6- 0	rx_pkt_latch [6:0] — RX packet length	These bits give the RX packet length parsed from the packet header. The value is latched when an RX Start Frame Delimiter is detected.

4.36 Timestamp_A - Register 2E

The Timestamp_A Register 2E stores the most significant 8 bits of the value in the Event Timer counter (et[23:0]) when the beginning of the most recent receive packet occurred. The value is latched immediately following reception of the FLI field and at the beginning of the payload data.



Table 4-37. Register 2E Description

Name	Description	Operation
Bits 15-8	Reserved	
Bits 7 - 0	timestamp [23:16] — 8 most significant bits of the latched 24-bit timestamp value for the beginning of the receive packet.	

4.37 Timestamp_B - Register 2F

The Timestamp_B Register 2F stores the least significant 16 bits of the value in the Event Timer counter (et[23:0]) when the beginning of the most recent receive packet occurred. The value is latched immediately following reception of the FLI field and at the beginning of the payload data.

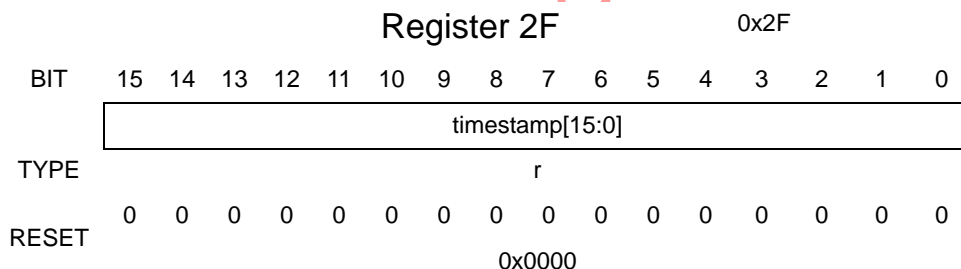

Table 4-38. Register 2F Description

Name	Description	Operation
Bits 15-0	timestamp[15:0] — 16 least significant bits of the latched 24-bit timestamp value for the beginning of the receive packet.	

4.38 BER_Enable - Register 30

The BER_Enable Register 30 contains the bit error rate test enable bit which allows the transceiver to be put into continuous receive or transmit mode. This feature has useful sequences in RF test configurations (see application note AN2976, *MC1319x RF Test Modes*). The default condition is with the continuous mode disabled.



Table 4-39. Register 30 Description

Name	Description	Operation
Bits 14-0	Reserved	
Bit 15	ber_en — The bit error rate test enable bit allows the transceiver to be put into continuous receive or transmit mode. Continuous TX Mode is useful for current measurements or for looking at TX spectrum. Continuous RX Mode is useful for looking at current.	1 = When a TX operation or RX operation is enabled, the transceiver stays in that operation until aborted. 0 = Continuous operation disabled; normal operation.

4.39 PSM_Mode - Register 31

The PSM_Mode Register 31 contains the phase shift modulator test mode field. The `psm_tm[2:0]` 3-bit field is only used in two modes. When `psm_tm[2:0] = 0b000`, there is normal TX modulation and normal operation. When `psm_tm[2:0] = 0b001`, the modulator is disabled and the transmitter puts out an unmodulated signal. When the unmodulated signal is combined with continuous TX operation (see BER_Enable Register 30), the unmodulated spectrum of the transmitter can be observed (see application note AN2976). Default is normal modulated operation.

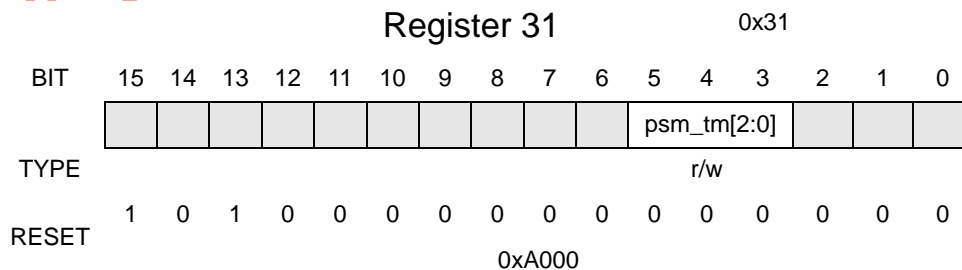

Table 4-40. Register 31 Description

Name	Description	Operation
Bits 15-6, 2-0	Reserved	
Bits 5-3	psm_tm[2:0] — Phase shift modulator test mode. Use only the two stated conditions.	<code>psm_tm[2:0] = 0b000</code> - normal modulated operation. <code>psm_tm[2:0] = 0b001</code> - modulator disabled.

Chapter 5

Serial Peripheral Interface (SPI)

5.1 Overview

Control of the MC13192 and data transfers are accomplished by means of a 4-wire Serial Peripheral Interface (SPI). The SPI port is a fully static design that requires no additional clocks besides SPICLK for accessing internal registers, although Packet RAM accesses do require the reference oscillator to be running. This allows for lower power when the SPI must stay alive while the rest of the device is in power-down.

Although the normal SPI protocol is based on 8-bit transfers, the MC13192 imposes a higher level transaction protocol that is based on multiple 8-bit transfers per transaction. In its simplest form, a singular SPI read or write transaction consists of an 8-bit header transfer followed by two 8-bit data transfers. The header denotes access type and register address. The following bytes are read or write data. The SPI also supports recursive 'data burst' transactions in which additional data transfers can occur. The recursive mode is primarily intended for Packet RAM access and fast configuration of the MC13192. Partial word accesses are not supported.

All SPI accessible registers are configured with 16-bit data width. The address range is 6 bits which allows for 64 locations although not all are implemented. Internal data RAMs are accessed as dedicated addresses within the register address field.

An additional feature is a software reset capability where a write to Address 00 will accomplish most of the equivalency of a hardware reset.

5.2 SPI Basic Operation

The MC13192 operates as a SPI Slave only. The host microcontroller supplies the interface clock and acts as SPI master.

5.2.1 SPI Pin Definition

The MC13192 SPI signals of CE, CPICLK, MOSI, and MISO are defined in the following paragraphs. A typical interconnection to a microcontroller is shown in [Figure 5-1](#).

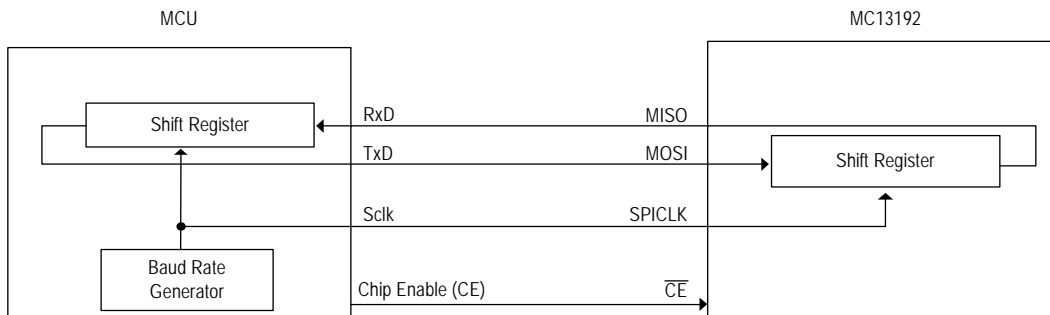

Figure 5-1. Typical SPI Connection with an MCU.

5.2.1.1 Chip Enable ($\overline{\text{CE}}$)

A transaction on the SPI port is framed by the active low Chip Enable ($\overline{\text{CE}}$) input signal which is driven by the host MCU. A transaction is a minimum of 3 SPI bursts and can extend to a greater number of bursts.

5.2.1.2 SPI Clock (SPICLK)

The host drives the SPI Clock (SPICLK) input to the MC13192. Data is clocked into the master or slave on the leading (rising) edge of the return-to-zero SPICLK and data out changes state on the trailing (falling) edge of SPICLK.

NOTE

For Freescale microcontrollers, the SPI clock format is the clock phase control bit CPHA = 0 and the clock polarity control bit CPOL = 0.

5.2.1.3 Master Out / Slave In (MOSI)

The Master Out/Slave In (MOSI) input presents incoming data from the host to the transceiver (slave input).

5.2.1.4 Master In / Slave Out (MISO)

The MC13192 presents data to the master on its MISO output. This output is user configurable for both drive strength and its off state.

5.2.1.4.1 Setting MISO Output Drive Strength

MISO output drive strength is programmed by writing to `miso_drv[1:0]`, GPIO_Data_Out Register 0C. There are 4 levels of drive strength with field value 00 for lowest and value 11 for greatest. The default value is 00.

NOTE

It is suggested the user program MISO for greatest drive strength for best performance.

5.2.1.4.2 Setting MISO Off Impedance

MISO off impedance (output state when $\overline{\text{CE}}$ is negated or high) can be programmed by writing to `miso_hiz_en`, Control_B Register 07. Setting `miso_hiz_en` to “1” causes MISO to tri-state when $\overline{\text{CE}}$ is high, and this is the default state. MISO must tri-state when $\overline{\text{CE}}$ is negated if other slave devices share the host SPI bus.

Writing `miso_hiz_en` to “0” causes MISO to be active low when $\overline{\text{CE}}$ is negated. This condition can be used when the transceiver is the only SPI slave.

5.2.2 SPI Burst Operation

The SPI port of an MCU transfers data in bursts of 8 bits with most significant bit (MSB) first. The master (MCU) can send a byte to the slave (transceiver) on the MOSI line and the slave can send a byte to the master on the MISO line. Although an MC13192 transaction is three or more SPI bursts long, the timing of a single SPI burst is shown in Figure 5-2.

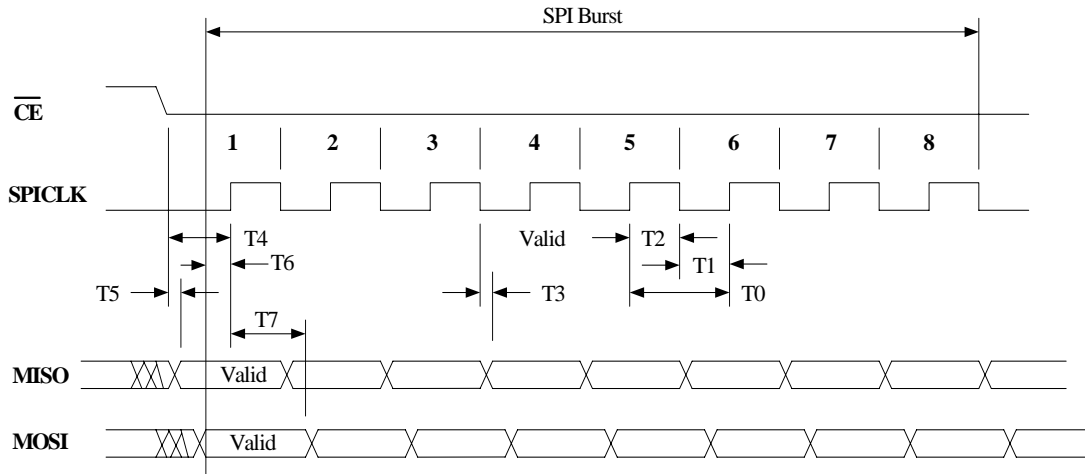

Figure 5-2. SPI Burst Timing Diagram

Table 5-1. SPI Timing Specifications

Symbol	Parameter	Min	Typ	Max	Unit
T0	SPICLK period	125			ns
T1	Pulse width, SPICLK low	50			ns
T2	Pulse width, SPICLK high	50			ns
T3	Delay time, MISO data valid from falling SPICLK		15		ns
T4	Setup time, \overline{CE} low to rising SPICLK		15		ns
T5	Delay time, MISO valid from \overline{CE} low		15		ns
T6	Setup time, MOSI valid to rising SPICLK		15		ns
T7	Hold time, MOSI valid from rising SPICLK		15		ns

5.3 SPI Singular Transactions

Although the SPI port of an MCU transfers data in bursts of 8 bits, the MC13192 requires that a complete SPI transaction be framed by \overline{CE} , and there will be 3 or more bursts per transaction. There are generally two classes of transactions, which are singular and recursive.

5.3.1 SPI Singular Transaction Signalling

The assertion of \overline{CE} to low signals the start of a transaction. The first SPI burst is a write of an 8-bit header to the transceiver (MOSI is valid) that defines a 6-bit address of the internal resource being accessed and identifies the access as being a read or write operation. In this context, a write is data written to the MC13192 and a read is data written to the SPI master. The following SPI bursts will be either the write data (MOSI is valid) to the transceiver or read data from the transceiver (MISO is valid).

Although the SPI bus is capable of sending data simultaneously between master and slave, the MC13192 never uses this mode. The number of data bytes (payload) will always be 2 for a singular access. After the final SPI burst, CE is negated to high to signal the end of the transaction. Should a SPI programming attempt fail to provide the MC13192 with at least 24 rising SPICLK edges prior to \overline{CE} negating, no register data will be changed.

Figure 5-3 shows a read access transaction and Figure 5-4 shows a write access transaction.

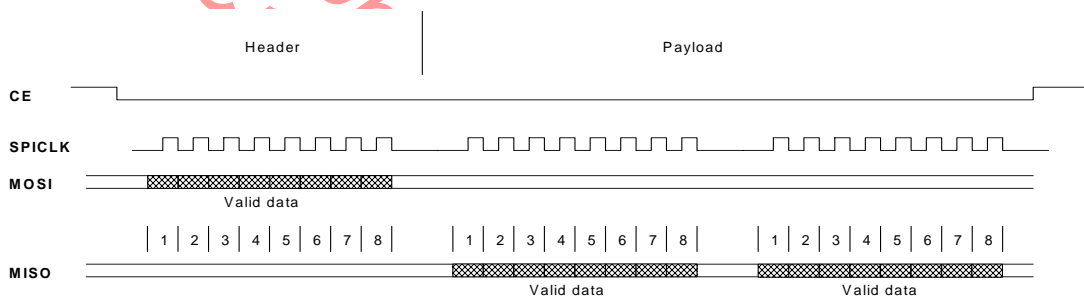

Figure 5-3. Singular Read Access

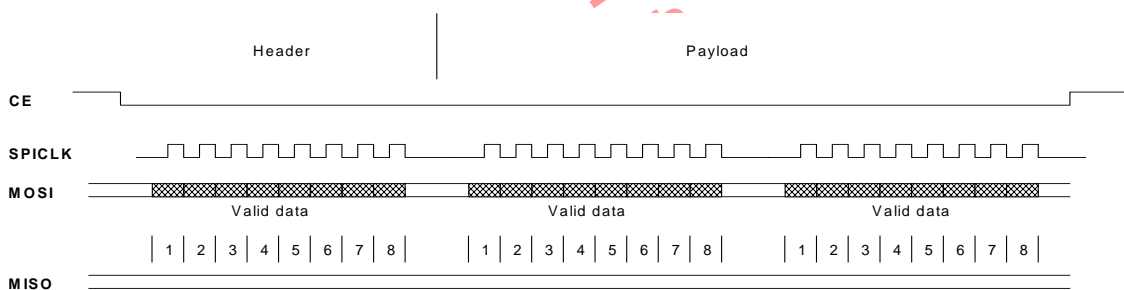

Figure 5-4. Singular Write Access

5.3.2 SPI Singular Transaction Protocol

A SPI transaction is divided into a header field and a payload. The header field is always 8 bits, while the payload data is in multiples of 2 bytes or 16 bits. A singular SPI transaction contains 24 bits of information. The header field contains a $\overline{R/W}$ bit and a 6-bit register address, as shown in Figure 5-5.

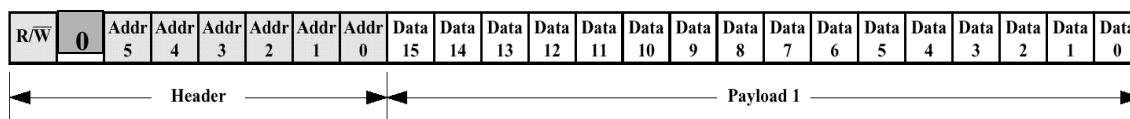

Figure 5-5. SPI Header and Payload Definition

The R/\overline{W} bit identifies the transfer as a read ($R/\overline{W} = 1$) or write ($R/\overline{W} = 0$). The lower 6 bits in the header determines which of the 64 possible SPI locations is to be accessed for a read or write operation although not all possible addresses are implemented. The register address field also provides the starting address for a recursive read or write operation as described later.

The register data is presented MSB first.

5.4 Symbol / Data Format

When the transceiver receives 802.15.4 symbols, they are assembled as 4 symbols per 16-bit word. They are then presented to the RX Packet RAM or to the SPI directly as a 16-bit word. The ordering of symbols vs. word bit ordering is shown in Figure 5-6 which details the RX data flow through the device. In Packet Mode the data is loaded into RX Packet RAM, and in Stream Mode the data is sent directly to the SPI buffer. When the symbols are read the SPI bus, 2 SPI bursts per 16-bit word are required and the MSB is presented first such that the symbols appear to the MCU in reverse order.

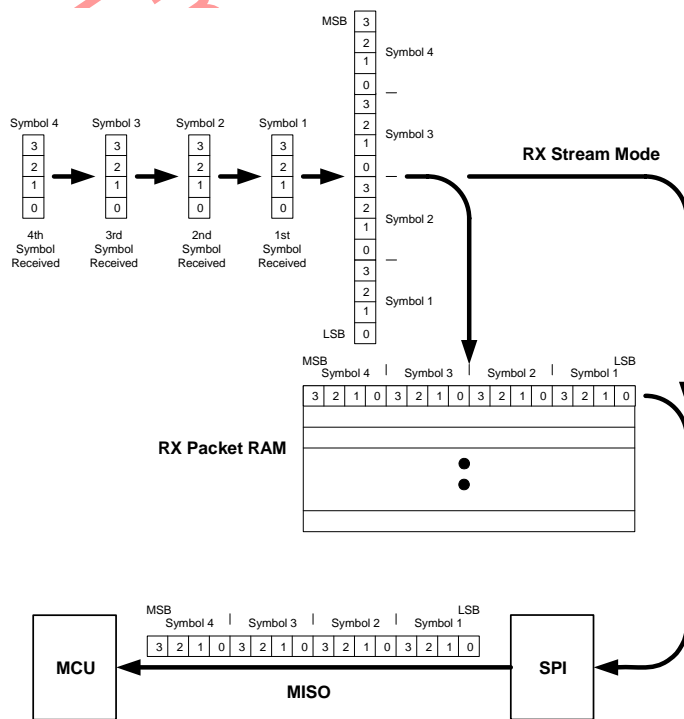

Figure 5-6. RX Symbol Flow Diagram

The inverse of the RX symbol / data flow is the case for TX data / symbols.

5.5 SPI Recursive Transactions

The MC13192 SPI also incorporates a recursive or ‘data burst’ transaction capability. This allows multiple sequential registers to be accessed with only one header field. Recursive reads and writes provide significant reduction in SPI overhead and a corresponding increase in programming speed.

1. The primary intent is for the software to be able to rapidly configure the MC13192.
2. Recursive reads and writes are convenient for accessing SPI register values which extend beyond the 16-bit SPI register format. Examples include writing Timer Comparator values (`tmr_cmp1[23:0]` through `tmr_cmp4[23:0]`) and reading the Time Stamp (`timestamp[23:0]`).
3. Recursive access capability enables the contents of Packet RAM to be read or written in an expedient manner.

5.5.1 Recursive SPI Register Read

Recursive register reads are invoked in an identical manner to singular read operations, however, by holding \overline{CE} asserted for additional SPI bursts after the first 16-bit data payload is shifted out, the contents of the next SPI register address is made available on the MISO pin. An internal SPI register address pointer is automatically incremented during recursive reads to point to the next sequential SPI register location. For each subsequent set of 2 SPI bursts, SPICLK shifts out the contents of the next register address.

This sequence repeats as long as the \overline{CE} is held asserted, allowing multiple sequential register contents of the SPI to be read starting at the header address. As the recursive read progresses, the SPI register address pointer continues to increment. When the address pointer reaches 63 decimal (the maximum implemented SPI register), the address pointer ‘rolls over’ to Address 03 and begins incrementing again. Address 03 is chosen to avoid the Program Reset function at Address 00 and the Rx Packet RAM and Tx Packet RAM at Addresses 01 and 02, respectively.

5.5.2 Recursive SPI Register Write

Recursive writes are invoked in an identical manner to singular write operations. But, by holding \overline{CE} asserted for additional SPI bursts after the first 16-bit data payload is shifted in, the contents of the next SPI register address can be programmed. An internal SPI register address pointer is automatically incremented during recursive writes to point to the next higher sequential SPI register location. For each subsequent set of 2 SPI bursts, SPICLK shifts in the write data to the next register address.

This sequence repeats as long as the \overline{CE} is held asserted, allowing multiple sequential register contents to be written starting at the header address. As the recursive write progresses, the SPI register address pointer continues to increment. When the address pointer reaches 63 decimal (the maximum implemented SPI register), the address pointer ‘rolls over’ to Address 03 and begins incrementing again. Address 3 is chosen to avoid the Program Reset function at Address 00 and the Rx Packet RAM and Tx Packet RAM at Addresses 01 and 02, respectively.

5.5.3 Special Case - Packet RAM Access

Packet RAM access is a special case access when the MC13192 is used in the Packet Mode. The MC13192 contains three embedded 128-byte 'Packet RAMs' used to facilitate reception and transmission of packet data. One RAM is dedicated for receive packet data and two are dedicated for transmit packet data. The Packet RAMs are configured in 64-word by 16-bit format and are both read and write accessible via the MC13192 SPI. The recursive data 'burst' access mode is used to efficiently access Packet RAM data.

Although the Packet RAMs are completely static, any RAM access requires the MC13192 to be in an active state; the reference clock circuit must be active. RAM read and write operations are prohibited while the device is in Hibernate or Doze mode.

Reading and writing the MC13192 Packet RAMs is accomplished by SPI burst accesses to dedicated Packet RAM register addresses within the register map. The RX_Pkt_RAM Register 01 is mapped to the Rx Packet RAM, and TX_Pkt_RAM Register 02 is mapped to the Tx Packet RAMs (choice is selected by the tx_ram2_select bit TX_Pkt_Ctl Register 03, Bit 15). The 16-bit data payload of the SPI access maps directly to the 16-bit word in the Packet RAM.

5.5.3.1 Recursive Receive Packet RAM Read Access

The receive Packet RAM is normally accessed when the MC13192 is in packet data mode and a valid frame has been received (as indicated by rx_rcvd_irq and crc_valid). The number of receive data bytes in the queue is shown by the rx_pkt_latch[6:0] field (this includes the full payload with the 2 CRC bytes).

The data is read by accessing RX_Pkt_RAM Register 01 with a recursive read. When accessing RX_Pkt_RAM Register 01, the SPI register address pointer is NOT incremented, instead, the Packet RAM read address pointer is incremented. Therefore, by using a recursive read, up to 64 words of packet memory can be read from the SPI with an access that requires but a single header field. A read access to Packet RAM always starts at the bottom of the RAM, i.e., the read address pointer always starts at the beginning of the data for a given read.

5.5.3.1.1 Receive Packet RAM Read Access Flow

Once receive data has been determined to be in Packet RAM, the following is a typical flow to read access the data:

1. Read rx_pkt_latch[6:0] to determine the number of payload bytes in receive Packet RAM. Note that this number includes 2 CRC bytes.
2. Calculate the number of SPI bursts that are required to access the Rx packet data, noting the following:
 - a) The CRC is not normally accessed, so the number of bytes is reduced by 2.

NOTE

If the 2-byte CRC data is read. The byte order is reversed (last CRC byte is read first).

- b) All data read during an access must be done on 16-bit or 2-byte boundaries. Therefore, for an odd number of bytes, the byte count must be rounded up to an even number.

Serial Peripheral Interface (SPI)

- c) The first word (or 2 bytes) read during a Packet RAM read should be discarded as the internal Packet RAM address is not accessed for the first word read operation. This has the effect of adding 2 bytes to the byte count.
3. Do a recursive SPI read transaction where:
 - a) MCU asserts \overline{CE} low.
 - b) MCU sends the MC13192 the first SPI burst with header field of R/ \overline{W} bit = 1 and address field Addr[5:0] = 0x01 for the RX_Pkt_RAM register address.
 - c) MCU reads MC13192 data with the number of SPI byte bursts as calculated in Number 2 above. Note that the first two bytes read from the MC13192 are discarded and that the number of SPI read bursts must be an even number. For an odd number of bytes, the one byte is also discarded.
 - d) MCU negates \overline{CE} high.

5.5.3.1.2 Receive Packet RAM Read Access Error Conditions

Two types of errors can occur during a Packet RAM read:

1. RAM address error - if the recursive read access exceeds 64 words (128 SPI data bursts), the internal read address counter will exceed the RAM address and generate an error indication via status bit ram_addr_err, IRQ_Status Register 24, Bit 14. An interrupt request can be generated with the error status by setting mask bit ram_addr_mask, IRQ_Mask Register 5, Bit 12. As with other interrupt requests, the status is cleared by reading the IRQ_Status register.
2. RAM arbitration busy - if the transceiver internal logic attempts to access the RAM during a SPI read access (a SPI read during an active Rx sequence), an error indication will be generated via status bit arb_busy_err, IRQ_Status Register 24, Bit 13. An interrupt request can be generated with the error status by setting mask bit arb_busy_mask, IRQ_Mask Register 5, Bit 11. As with other interrupt requests, the status is cleared by reading the IRQ_Status register.

5.5.3.2 Recursive Transmit Packet RAM Write Access

The transmit Packet RAM is normally accessed when the MC13192 is in packet data mode and a frame is to be transmitted. The number of transmit data bytes in the transmit queue is loaded into the tx_pkt_length[6:0] field (this represents the full payload which includes the data bytes stored in the transmit Packet RAM plus the 2 CRC bytes).

The data is written to the TX_Pkt_RAM Register 02 with a recursive access. When accessing TX_Pkt_RAM Register 02, the SPI register address pointer is NOT incremented, instead, the Packet RAM write address pointer is incremented. Therefore, by using a recursive write, up to 64 words of packet memory can be written via the SPI with an access that requires but a single header field. A write access to Packet RAM always starts at the bottom of the RAM, i.e., the write address pointer always starts at the beginning of the data for a given write.

5.5.3.2.1 Transmit Packet RAM Write Access Flow

Before data is actually written to the Tx Packet RAM, the Tx payload length must be written into field `tx_pkt_length[6:0]`, `TX_Pkt_Ctl` Register 03, Bit 6 - 0. The maximum length is 127 bytes and is the number of actual payload bytes transmitted which includes 2 CRC bytes. The CRC bytes transmitted are generated by the transceiver hardware and are not loaded into the Packet RAM.

The following is a typical flow to write data to the Packet RAM:

1. Determine which of the two Transmit Packet RAMs are to be used - If Transmit Packet RAM2 is to be used, set status bit `tx_ram2_select`, `TX_Pkt_Ctl` Register 03, Bit 15. The default is Transmit Packet RAM1 selected. Note that the `tx_ram2_select` status determines which transmit Packet RAM is accessed by an SPI transaction as well as which RAM is used during transmit mode.
2. Calculate the number of SPI bursts that are required to write the Tx packet data, noting the following:
 - a) The CRC bytes are not written to Transmit Packet RAM.
 - b) The maximum number of Tx packet data bytes is 125.
 - c) All data written during an access must be done on 16-bit or 2-byte boundaries. Therefore, for an odd number of bytes, the byte count must be rounded up to an even number and an extra dummy byte will be written.
3. Do a recursive SPI write transaction where:
 - a) MCU asserts \overline{CE} low.
 - b) MCU sends the MC13192 the first SPI burst with header field of R/\overline{W} bit = 0 and address field `Addr[5:0] = 0x02` for the `TX_Pkt_RAM` register address.
 - c) MCU writes the MC13192 data with the number of SPI byte bursts as calculated in Step 2. The number of SPI write bursts must be an even number.
 - d) MCU negates \overline{CE} high.

5.5.3.2.2 Transmit Packet RAM Write Access Error Conditions

Two types of errors can occur during a Packet RAM write:

1. RAM address error - This can occur during software development and debug. If the recursive write access exceeds 64 words (128 SPI data bursts), the internal read address counter will exceed the RAM address and generate an error indication via status bit `ram_addr_err`, `IRQ_Status` Register 24, Bit 14. An interrupt request can be generated with the error status by setting mask bit `ram_addr_mask`, `IRQ_Mask` Register 5, Bit 12. As with other interrupt requests, the status is cleared by reading the `IRQ_Status` register.
2. RAM arbitration busy - if the transceiver internal logic attempts to access the RAM during an SPI write access (an SPI access during an active Tx sequence), an error indication will be generated via status bit `arb_busy_err`, `IRQ_Status` Register 24, Bit 13. An interrupt request can be generated with the error status by setting mask bit `arb_busy_mask`, `IRQ_Mask` Register 5, Bit 11. As with other interrupt requests, the status is cleared by reading the `IRQ_Status` register.

5.6 Program Reset (Writing Address 0x00)

A special access is a software reset capability known as a “Software Reset”. When $\overline{R/\overline{W}}$ Register Address 0x00 is written, an internal chip reset of the digital core is generated. All synchronous logic in the MC13192 digital core is reset and the SPI register fields are returned to their default values. This Software Reset has the same effect on the MC13192 digital core as asserting the external \overline{RST} pin except RAM contents are retained.

The Software Reset asserts internally as soon as the 8-bit header field containing Address 0 is shifted into the MOSI pin and a write operation is specified. The Software Reset remains asserted internally until the \overline{CE} pin is negated. Reading from Register 00 does not generate a reset.

Not Recommended for New Designs.
MC1320x.

Chapter 6

Modes of Operation

6.1 Operational Modes Summary

The MC13192 has a number of passive operational modes that allow for low-current operation as well as modes where the transceiver is active. These modes are summarized, along with the transition times, in Table 6-1. Figure 6-1, Figure 6-2, Figure 6-3 and Figure 6-4 show the state diagrams for different operational modes.

Table 6-1. MC13192 Mode Definitions and Transition Times

Mode	Definition	Transition Time
Off	\overline{RST} asserted. All IC functions Off, Leakage only. Digital outputs are tri-stated including IRQ. Any RAM buffer data is lost.	10 - 25 ms to Idle
Hibernate	Crystal Reference Oscillator Off. SPI not functional. IC Responds to \overline{ATTN} . Data is retained.	8 - 20 ms to Idle
Doze	Crystal Reference Oscillator On but CLKO is available only if Register 7, Bit 9 = 1 for frequencies of 1 MHz or less. (SPI not functional.) Responds to \overline{ATTN} and can be programmed to enter Idle Mode through an internal timer comparator.	$(300+1/CLKO) \mu s$ to Idle
Idle	Crystal Reference Oscillator On with CLKO output available. SPI active.	
Receive	Crystal Reference Oscillator On. Receiver On.	144 μs from Idle
Transmit	Crystal Reference Oscillator On. Transmitter On.	144 μs from Idle
CCA / Energy Detect	Crystal Reference Oscillator On. Receiver On.	144 μs from Idle

Idle mode is normally the state from which other states are derived. Low power states include the Off, Hibernate, and Doze modes. The Off state is the lowest power and is caused by the hardware reset. Transition from the Off to Idle mode occurs when \overline{RST} is negated to high. Once in Idle mode, the SPI is active and used to control the MC13192. Transition to Hibernate or Doze modes is enabled via the SPI.

There are active states of Idle, Transmit (TX), Receive (RX), and Clear Channel Assessment (CCA) modes. The transition from the Idle state to the TX or RX is first determined by the desired data mode of the user, i.e., Packet Mode or Stream Mode. If packet data mode is used, writing to the `xcvr_seq` field can select RX or TX in packet mode. Packet RX and TX can also be modified as timer-based sequences using `Tmr_Cmp2`. Figure 6-1 and Figure 6-2 show state diagrams for Packet Mode transceiver operations without and with timer-initiated sequences.

If stream data mode is used, then the configuration bits of `tx_strm`, `rx_strm`, and `use_strm_mode` control transition to the TX and RX sequences. `Use_strm_mode` is a top level control bit and enables a sequence as selected by either `tx_strm` or `rx_strm` (only one bit should be set to 1 at a time). Also, when using Stream Mode, the `xcvr_seq` field should be set to 0x0 so the selected TX or RX sequence starts from the Idle condition. As with the Packet Mode, the Stream Mode can be modified to have timer-initiated sequences, only for this case `TC2_Prime` is used as the timer comparator. Figure 6-3 and Figure 6-4 show state diagrams for Stream Mode transceiver operations without and with timer-initiated sequences.

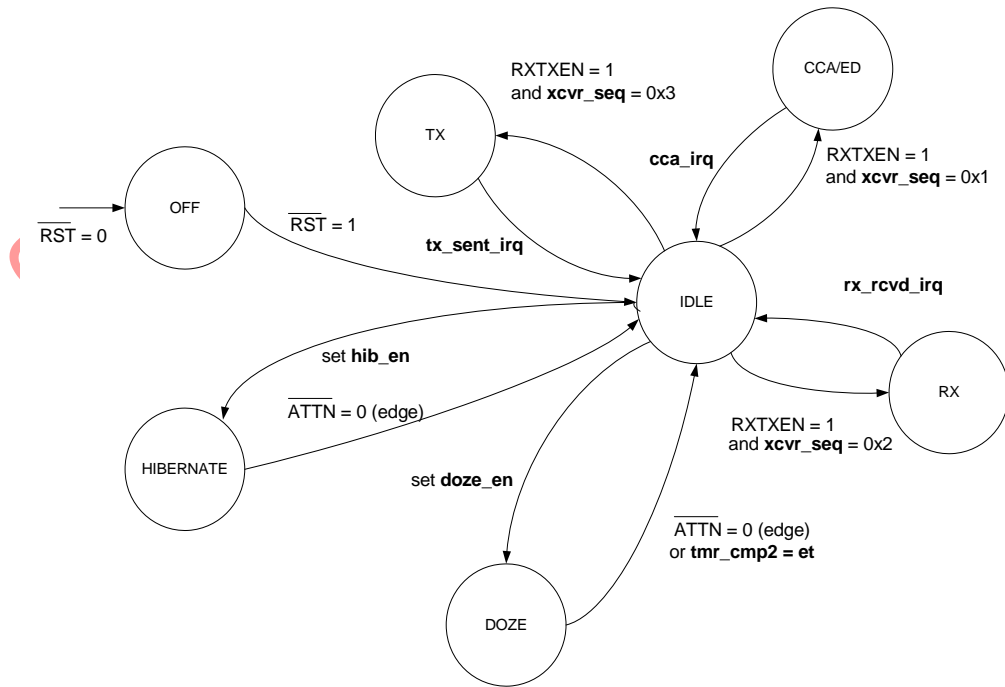

Figure 6-1. State Diagram for Packet Mode Without Timer Enabled States

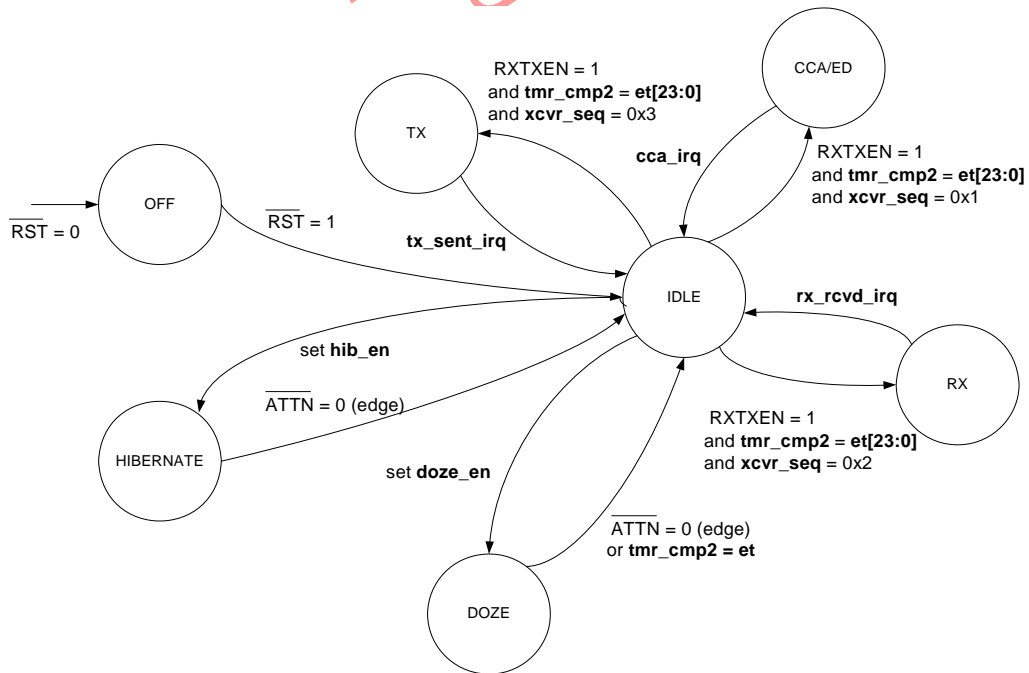

Figure 6-2. State Diagram for Packet Mode With Tmr_Cmp2 Enabled States ($\text{tmr_trig_en} = 1$)

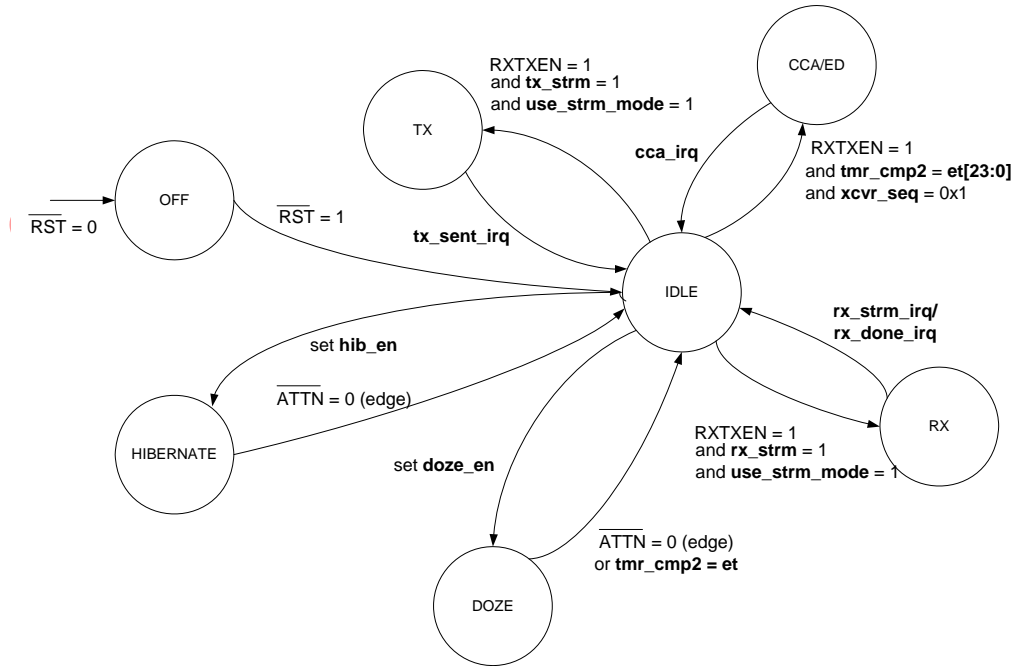

Figure 6-3. State Diagram for Stream Mode Without Timer Enabled States

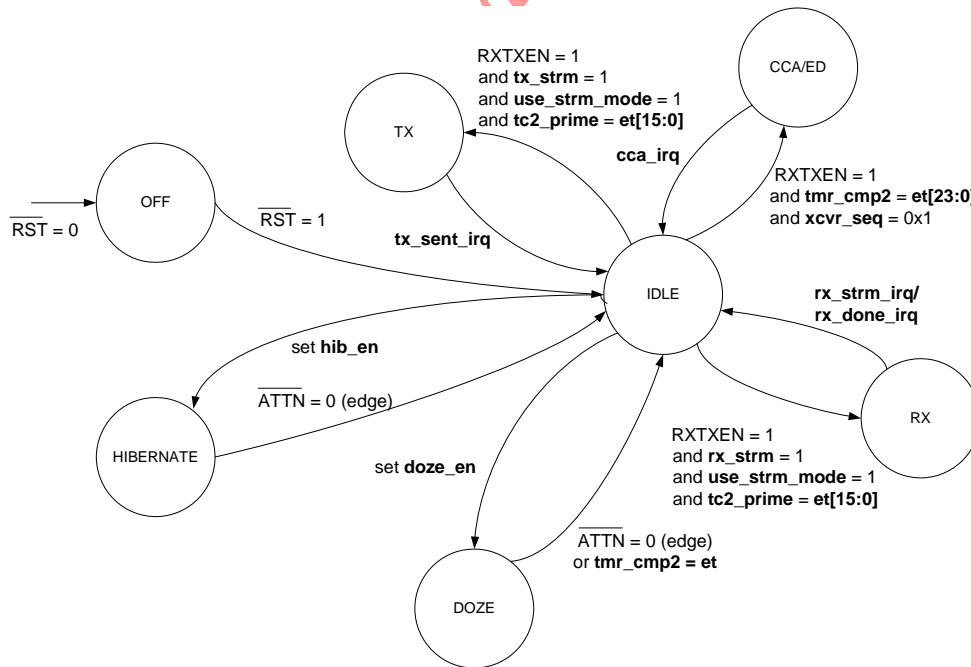

Figure 6-4. State Diagram for Stream Mode With TC2_Prime Enabled State ($\text{tmr_trig_en} = 1$)

6.2 Low Power Modes

The MC13192 supports several low-power modes where the transceiver circuitry is not active. Each mode has a different advantage, these modes are described in the following sections.

6.2.1 Off Mode

The Off or Reset condition has the absolutely lowest power, and is controlled by the $\overline{\text{RST}}$ input. As long as $\overline{\text{RST}}$ is asserted low the MC13192 remains in the Off mode. All functions are disabled and no RAM data is retained. Current draw is attributed to leakage only.

To exit Off mode, $\overline{\text{RST}}$ is negated high. The MC13192 then moves to Idle mode within 25 milliseconds.

6.2.2 Hibernate Mode

Although the Off or Reset condition has the lowest possible power, the Hibernate mode has the next lowest power. All hardware blocks are deactivated (including the SPI interface) and no timers are running. Internal voltage regulation is dropped to less than 1 Vdc. Hibernate mode has the advantage of retention of all RAM data (which does not occur in the Off mode) and of the SPI configuration prior to entering Hibernate mode.

Hibernate mode is entered from Idle by programming `hib_en`, Control_B Register 07, Bit 1, to “1”. Hibernate is then entered 128 CLKO cycles after `hib_en` is set. The normal way to exit from Hibernate mode is to assert $\overline{\text{ATTN}}$ which will cause the MC13192 to go to Idle mode. The MC13192 then moves to Idle mode within 20 milliseconds. Asserting $\overline{\text{RST}}$ forces the Off condition.

On entering Hibernate Mode, 128 clock cycles are available at CLKO before the clock is disabled. These 128 CLKO cycles allow a host that uses CLKO as a source clock to attain a low power state prior to losing clock. After the 128 CLKO cycles, the transceiver transitions to the low power state.

Upon exiting Hibernate, CLKO will restart (if enabled) with the same frequency as programmed before before entering Hibernate.

6.2.3 Doze Mode

Doze mode has variations of normal Doze mode and a subset called Acoma state.

6.2.3.1 Normal Doze Mode

Doze mode is an additional low power state specifically designed to work in concert with the Event Timer. Most internal hardware blocks are de-activated (including the SPI interface) and internal regulation is reduced, but the reference oscillator and Event Timer are active. Internal RAM data and SPI configuration are retained similar to Hibernate mode.

In Doze mode, CLKO can optionally be made available by setting `clko_doze_en`, Control_B Register 07, Bit 9, with the disadvantage of increased power consumption. The CLKO frequency must be set for 1 MHz or lower. If `clko_doze_en` = 0, then CLKO is disabled 128 clock cycles after entering Doze mode. After the 128 CLKO cycles, the transceiver transitions to the low power state.

Doze mode is entered from Idle by programming `doze_en`, Control_B Register 07, Bit 0, to “1”. Doze mode is then entered 128 CLKO cycles after `doze_en` is set.

The intended primary way to exit Doze mode is through a “wake-up” timer and return to Idle at a pre-determined time. This will occur when the Event Timer equals the value in `tmr_cmr2[23:0]`, `Tmr_Cmp2`, Registers 1D and 1E. When the match occurs, The MC13192 exits Doze, sets status bit `doze_irq`, IRQ_Status Register 24, Bit 9, and returns to Idle. An interrupt request will be generated if the `doze_mask` IRQ_Mask Register 05, Bit 4, has been set.

If CLKO was enabled before Doze mode and disabled during Doze mode, the CLKO will automatically re-start after exiting Doze with the exception of two frequencies. The two lowest frequencies of 16.393+ kHz and 32.786+ kHz will not restart directly when exiting Doze mode. To restart CLKO for these frequencies, the `clko_en`, Control_C Register 09, Bit 2, must be cleared and set again.

Doze mode can be exited at any time similar to Hibernate by asserting \overline{ATTN} or \overline{RST} . If Doze is exited by asserting \overline{ATTN} and the Event Timer was activated and waiting on a timeout to waken, the timer should be disabled or the timeout will still happen and generate a status and possible interrupt.

6.2.3.2 Acoma Doze Mode

A subset of Doze mode without timer wake-up is the Acoma state that has the advantage of lowest power with data retention while allowing CLKO to run. This mode disables the Event Timer and prescaler, but allows the clock to run and have CLKO available. Timers are not available so only \overline{ATTN} will return the device to Idle or a \overline{RST} can be used to exit. Acoma mode is entered by setting `acoma_en`, IRQ_Mask Register 05, Bit 8 = 1.

6.3 Active Modes

There are four active modes for the MC13192 which include, Idle, Transmit (TX), Receive (RX) and Clear Channel Assessment (CCA)/Energy Detect (ED).

6.3.1 Idle Mode

Idle Mode is the default mode after leaving one of the low-power modes and is the basic active state from which all other activity is initiated. In Idle Mode, the receiver hardware and transmitter hardware are shut down waiting for a command. The command can instruct the MC13192 to transition to Receive mode, Transmit mode, CCA mode, or to one of the low-power modes. The CCA / ED mode (in its variations) is called by writing to the `xcvr_seq[1:0]` field, Control_A Register 06, Bits 1 - 0.

The transitions to RX Mode or TX Mode, however, are dependent upon the desired data mode. For example, Packet Mode or Stream Mode. In packet data mode, the transition to RX Mode or TX Mode is determined by writing the appropriate value to the `xcvr_seq[1:0]` field. Alternately, stream data mode uses control bits `use_strm_mode`, `rx_strm`, and `tx_strm` to cause transition to an RX or TX mode (in this case, the `xcvr_seq[1:0]` field should not be written).

Once CCA, Receive, or Transmit is entered, the MC13192 will transition back to the Idle mode upon completion of the selected operation. For packet mode, at the end of the operation the `xcvr_seq[1:0]` field

will not be cleared to an Idle value although the transceiver returns to the Idle condition. In this case, a read from the `xcvr_seq[1:0]` field will return the code of the last programmed operation.

In Idle Mode, the crystal oscillator is active, CLKO is available (if enabled), and the SPI is active.

6.3.2 Controlling Transition to Other Active Modes from Idle

Reviewing the state diagrams in [Figure 6-1](#), [Figure 6-2](#), [Figure 6-3](#), and [Figure 6-4](#), shows that the input signal RXTXEN must be asserted to allow transition from Idle to other active states. The recommended procedure is that RXTXEN is taken low while setting-up the desired function (writing required registers) and then after SPI transactions, the MCU raises RXTXEN to a high state enabling the transition. For timed functions (using either `tmr_cmp2` or `tc2_prime`), the same procedure holds with the exception that the transition will be delayed until the timer function completes.

6.3.3 Packet Mode Data Transfer TX and RX Operation

Packet mode assumes use of the onboard buffer RAMs and has the advantage of using less of the MCU resources. The Idle mode is the condition from which RX and TX modes are initiated. Writing to the `xcvr_seq[1:0]` field arms the transition to the desired mode (`use_strm_mode = 0`, `tx_strm = 0`, and `rx_strm = 0`). However, the RXTXEN signal must also be high for the transition to occur and if the Event Timer is enabled, the transition will be synchronized to the timer compare event. Once Receive or Transmit is entered, the MC13192 will transition back to the Idle mode upon completion of the selected operation.

[Table 6-2](#) shows the transceiver sequence field modes.

Table 6-2. Transceiver Sequence Field (`xcvr_seq[1:0]`)

Mode	Value	Description
Idle	00	Idle mode - default state after exiting low-power modes
CCA / Energy Detect	01	CCA / Energy detect - special case of receive used to monitor channel energy
Packet Receive	10	Packet Receive
Packet Transmit	11	Packet Transmit

The selected mode is controlled by:

1. `xcvr_seq[1:0]` field - Shown in [Table 6-2](#).
2. RXTXEN signal - The transition to any other active mode from Idle will not occur unless RXTXEN is asserted high.
3. `tmr_trig_en`, Control_A Register 06, Bit 7 - When `tmr_trig_en` is set to “1”, the transition to the selected active mode will be based on a `tmr_cmp2[23:0]` compare function as described in the Event Timer section. When `tmr_trig_en` is cleared to “0”, the transition to the selected active mode is based only on programming of `xcvr_seq[1:0]`. For both cases, RXTXEN must be high and overrides.
4. For Packet Mode, `tx_strm`, `rx_strm` and `use_strm_mode` control bits must always be cleared to zero.

6.3.3.1 Packet Receive Mode

Receive mode is the state where the transceiver is waiting for an incoming data frame. The advantage of packet receive mode is that it allows the MC13192 to receive the whole packet without intervention from the microcontroller. The entire packet payload is stored in RX Packet RAM and the microcontroller fetches the data after determining the length and validity of the RX packet. The disadvantage of Packet Mode is that there is a significant latency to reading the RX data via a SPI recursive access, processing the frame data and providing a response if required; the streaming mode is better suited to faster response time.

The MC13192 waits for preamble followed by a Start of Frame Delimiter. From there, the Frame Length Indicator is used to determine length of the frame and calculate CRC. The receive function provides the following frame information/data:

1. The frame payload data - accessed through rx_pkt_ram[15:0] RX_Pkt_RAM Register 01.
2. CRC valid status - reported by crc_valid, IRQ_Status Register 24, Bit 0.
3. Payload data length - reported by rx_pkt_latch[6:0], RX_Pkt_Latch Register 2D, Bits 6 - 0.
4. Link quality indicator (LQI) - this is a measure of the received energy that occurs during the received frame. Once a preamble is detected, the received energy is measured over a 64 μ s period and stored in cca_final[7:0], RX_Pkt_Latch Register 2D, Bits 15 - 8.

NOTE

After a frame is received, the application must determine the validity of the packet. Due to noise, it is possible for an invalid packet to be reported with either of the following conditions:

- a.) A valid CRC and a frame length of 0,1, or 2.
- b.) Invalid CRC and invalid frame length.

The application software needs to verify that:

- a.) The CRC is valid.
- b.) The frame length is valid with a value of 3 or greater.

NOTE

The packet mode is not used for the Freescale 802.15.4 Standard compatible MAC. However, it is used in the Freescale SMAC. If users write their own software, they should also pad TX frame length to be an odd number of bytes.

The following is a typical sequence for packet receive operation (not using a timer-based start):

1. The RX frequency must be programmed.
2. If not already low, the MCU sets RXTXEN low.
3. Control bits cleared (no Stream Mode and no timer):
 - a) tmr_trig_en = 0
 - b) tx_strm = 0
 - c) rx_strm = 0

Modes of Operation

- d) use_strm_mode = 0
- 4. rx_rcvd_mask, Control_A Register 06, Bit 8 is programmed to “1” to enable an interrupt request when the RX packet has been received.
- 5. Transceiver sequence is programmed to xcvr_seq[1:0] = 0x2 for receive.
- 6. RXTXEN must be asserted and held high.
- 7. When a packet is successfully received, the following are reported:
 - a) rx_pkt_latch[6:0], RX_Pkt_Latch Register 2D, Bits 6 - 0 - reports the length of the packet payload including 2 bytes of CRC data.
 - b) crc_valid, IRQ_Status Register 24, Bit 0 - reports the results of the CRC check, where a “1” indicates valid CRC.
 - c) cca_final[7:0], RX_Pkt_Latch Register 2D, Bits 15 - 8 - reports Link Quality Indicator.
 - d) rx_rcvd_irq, IRQ_Status Register 24, Bit 7- reports the completion of packet reception, where a “1” indicate complete status. Also, an interrupt is generated due to the valid status.
- 8. In response of the interrupt request from the MC13192, the microcontroller does the following:
 - a) Determines the validity of the frame by reading and checking rx_rcvd_irq and crc_valid. Determines a valid length for the frame by reading rx_pkt_latch[6:0].
 - b) Reads the payload data from RX Packet RAM using a recursive read from rx_pkt_ram[15:0] RX_Pkt_RAM Register 01.

6.3.3.2 Aborting a Packet Receive Sequence

It may be required to abort a packet receive sequence. The RX sequence can be aborted by either negating RXTXEN to low or by writing xcvr_seq[1:0] to 0x0. If either of these conditions happen, the transceiver returns to Idle mode and no additional status bit is set.

6.3.3.3 Packet Transmit Mode

The advantage of packet transmit mode is that it allows the MC13192 to send the whole packet without intervention from the microcontroller. The entire packet payload is pre-loaded in TX Packet RAM, the MC13192 sends the frame, and then the transmit complete status is given to the MCU.

NOTE

The packet mode is not used for the Freescale 802.15.4 compatible MAC, however, it is used by the Freescale SMAC software. On the RX side, an even number of bytes in the frame length can occasionally cause the RX data to read as all zeroes. If users write their own software, they should pad TX frame length to be an odd number of bytes.

NOTE

Once a TX sequence is started, it should not be aborted. Wait for the tx_sent_irq status and interrupt. If the TX sequence is aborted, it is best practice to reset the transceiver.

The following is a typical sequence for packet transmit operation (not using a timer-based start):

1. The TX frequency must be programmed.
2. If not already low, the MCU sets RXTXEN low.
3. Control bits cleared (no Stream Mode and no timer):
 - a) `tmr_trig_en = 0`
 - b) `tx_strm = 0`
 - c) `rx_strm = 0`
 - d) `use_strm_mode = 0`
4. `tx_sent_mask`, Control_A Register 06, Bit 9 is programmed to “1” to enable an interrupt request when the TX packet has been sent.
5. The MCU loads the value of the number of data bytes plus two (for FCS) into `tx_pkt_length[6:0]` TX_Pkt_Ctl Register 03, Bits 6 - 0.
6. The MCU then pre-loads the number of actual data bytes into `tx_pkt_ram[15:0]` TX_Pkt_RAM register 02 with a recursive SPI write. An odd number of data bytes requires stuffing a dummy byte due to the 16-bit SPI data format.
7. Transceiver sequence is programmed to `xcvr_seq[1:0] = 0x3` for transmit.
8. RXTXEN must be asserted and held high.
9. When the packet is successfully transmitted, `tx_sent_irq` reports the completion of packet transmission, where a “1” indicates a complete status. Also, an interrupt is generated due to the valid status.
10. In response of the interrupt request from the MC13192, the microcontroller reads the status to clear the interrupt and check successful transmission.

6.3.4 Stream Mode Data Transfer TX and RX Operation

Stream Mode does not use the onboard buffer RAMs and presents the data to the SPI buffer on a word-by-word basis. The Idle mode is the condition from which RX and TX modes are initiated. In Stream Mode, control bits `tx_strm`, `rx_strm` and `use_strm_mode` control transition to RX or TX modes (`xcvr_seq[1:0]` must equal 00 for Idle). However, the RXTXEN signal must also be high for the transition to occur and if the Event Timer is enabled, the transition will be synchronized to the TC2_Prime compare event. Once Receive or Transmit is entered, the MC13192 will transition back to the Idle mode upon completion of the selected operation.

The selected mode is controlled by:

1. For Stream Mode, `xcvr_seq[1:0]` field must be cleared to zero.
2. `use_strm_mode`, Control_B Register 07, Bit 5 - Set to “1” first to enable Stream Mode.
3. `rx_strm`, Control_A Register 06, Bit 11, and `tx_strm`, Control_A Register 06, Bit 12 - These bits are used to initiate RX or TX operation once Stream Mode is selected.
 - a) `rx_strm` is set to 1 to initiate a RX sequence (`tx_strm` stays at 0)
 - b) `tx_strm` is set to 1 to initiate a TX sequence (`rx_strm` stays at 0)

Modes of Operation

4. RXTXEN signal - The transition to any other active mode from Idle will not occur unless RXTXEN is asserted high. This signal may be held high to allow the transitions to occur based on SPI programming and/or Event Timer activity.
5. tmr_trig_en, Control_A Register 06, Bit 7 - When tmr_trig_en is set to “1”, the transition to the selected active mode will be based on a tc2_prime[15:0] compare function as described in the Event Timer section. For Stream Mode, tc2_prime[15:0] takes the place of tmr_cmp2[23:0] making the compare function based on a 16-bit value as opposed to a 24-bit value. Also, tc2_prime[15:0] uses the tmr2_irq when the transceiver is in Stream Mode. When tmr_trig_en is cleared to “0”, the transition to the selected active mode is based only on programming of the stream control bits. For both cases, RXTXEN must be set high.

The Stream Mode requires that the host MCU either normally supply a data word every 64 microseconds for a TX sequence or read a data word every 64 microseconds for a RX sequence (with the exception shown being in the note below). If this timing requirement is violated, a strm_data_err status will be issued causing an interrupt request if enabled. The use of the interrupts is important to supporting stream data mode.

For TX mode once the sequence has been initiated, an interrupt (tx_strm_irq bit) is generated for every new data word required for the packet (excluding the CRC data). The MCU is required to write the data word to TX_Pkt_RAM Register 02 within the 64 microsecond interval. Writing the TX word will clear the interrupt request and thus saves an access to the IRQ_Status Register 24 to clear the \overline{IRQ} . An interrupt will also be generated to signal the completion of the TX operation via the tx_done_irq bit.

The RX mode is slightly more complex. Once a RX sequence has been initiated and a RX packet is being received, the first interrupt generated (rx_strm_irq bit) is for the MCU to read the RX Packet Length from Register 2D. Reading Register 2D will clear the interrupt and saves a read of the IRQ_Status Register 24. There will be a following interrupt (rx_strm_irq bit) for each received data word and the interrupt can be cleared by reading the data from RX_Pkt_RAM Register 01. The data must be read within the 64 microsecond period, and no interrupt will be generated for the received CRC data. An interrupt will also be generated for the completion of the RX operation via the rx_done_irq bit.

NOTE

- There is one exception to the 64 microsecond response time. For the stream receive sequence and an odd byte length packet, the last data transfer only has 8 bits (one byte) of valid data and the data will only be available for 32 microseconds. If the packet length is even, the full 64 microseconds is available.
- If the timing of the last data transfer on a stream receive is violated, a strm_data_err status will not be issued and the user software must take this into account.

These are described in more detail in the following sections.

6.3.4.1 Stream Receive Mode

The advantage of stream receive mode is that it allows the microcontroller to fetch data from the MC13192 as soon as the data arrives. As a result the MCU can begin processing frame information as it arrives and provide a quicker turn-around time if a response is required. The disadvantage of Stream Mode is that there is a significant amount of overhead required from the MCU to process incoming data on a word-by-word basis.

NOTE

Similar to packet receive mode, after a frame is received, the application must determine the validity of the packet. Due to noise, it is possible for an invalid packet to be reported with either of the following conditions:

- a.) A valid CRC and a frame length of 0,1, or 2
- b.) Invalid CRC and invalid frame length

The application software needs to verify that:

- a.) The CRC is valid
- b.) The frame length is valid with a value of 3 or greater

The following is a typical sequence for stream receive operation not using a timer-based start (note that `xcvr_seq[1:0]` field = 00):

1. The RX frequency must be programmed.
2. If not already low, the MCU sets RXTXEN low.
3. RX control bits must be initiated (Stream Mode and no timer):
 - a) `tmr_trig_en = 0`
 - b) `use_strm_mode = 1`
 - c) `tx_strm = 0`
4. Program `gpio_alt_en = 1` to enable GPIO1 as an “out-of-idle” indicator and GPIO2 as a CRC “valid” indicator.
5. `rx_rcvd_mask`, Control_A Register 06, Bit 8 is programmed to “1” to enable an interrupt request when a word of RX payload data is ready to be read.
6. `rx_done_mask`, Control_B Register 07, Bit 6 is programmed to “1” to enable an interrupt request when the RX packet has been fully received.
7. `rx_strm`, Control_A Register 06, Bit 11 is programmed to “1” to enable the stream RX sequence.
8. RXTXEN must be asserted and held high.
9. The receiver will await preamble followed by a SFD. After receiving these, the next byte is the FLI and gets stored in `rx_pkt_latch[6:0]`. The `rx_strm_irq`, IRQ_Status Register 24, Bit 7 will get set and generates an interrupt request on $\overline{\text{IRQ}}$.
10. The MCU should read RX_Status Register 2D to fetch the `rx_pkt_latch[6:0]` to clear the $\overline{\text{IRQ}}$. Note that LQI is valid at this time and can be fetched with the same read because `cca_final[7:0]` is the LQI value and is RX_Status Register 2D, Bits 15-8.

NOTE

The MCU must respond to the interrupt within 64 microseconds and use the FLI data to determine the number of data fetches that will be required for the packet data.

11. As the payload data arrives, it gets stored in a 2-byte wide buffer and the rx_strm_irq gets set to indicate data is ready and also generates an interrupt request.
12. The microcontroller must respond to the interrupt by reading the RX data from rx_pkt_ram[15:0], RX_Pkt_RAM Register 01. Reading the data clears the interrupt request.

NOTE

The MCU must respond to the interrupt request within 64 microseconds. Steps 10 and 11 get repeated as required for the payload data. No interrupt is generated and no data is available for the FCS word.

13. When a packet is successfully received, the following are reported:
 - a) crc_valid, IRQ_Status Register 24, Bit 0 - reports the results of the CRC check, where a “1” indicates valid CRC. GPIO2 also reports valid CRC
 - b) cca_final[7:0], RX_Pkt_Latch Register 2D, Bits 15 - 8 - reports Link Quality Indicator
 - c) rx_done_irq, IRQ_Status Register 24, Bit 13 - reports the completion of packet reception, where a “1” indicates complete status. Also, an interrupt is generated due to the valid status
14. In response of the interrupt request from the MC13192, the microcontroller checks status to clear the interrupt and check the validity of the RX packet.

In between reading of the payload data, the MCU can be processing the data as it arrives. In this manner once the frame has been validated, the MCU can respond with a reply (if required) with a minimum amount of latency.

6.3.4.2 Aborting a Stream Receive Mode Sequence

It may be required to abort a stream receive sequence. The sequence should be aborted by negating RXTXEN to low. The RX sequence will be terminated and the transceiver will return to the Idle condition. The rx_done_irq status will be set and generate an interrupt (if enabled).

Because of the streaming data mode, it is possible for a strm_data_err status/interrupt to occur up to 64 μ sec after the transceiver returns to Idle. Driver software must deal with this extraneous interrupt by not reacting to it other than to clear the status by reading the IRQ_Status Register 24. One means of detecting that the interrupt is not valid is to monitor the Idle state of the transceiver through use of GPIO1 (out of idle) indicator, such that if the interrupt occurs while the transceiver is in idle, then the interrupt status must be cleared and ignored.

6.3.4.3 Stream Transmit Mode

The advantage of stream transmit mode is that it allows the microcontroller to start a transmission without the latency of pre-loading the TX data into the TX Packet RAM. The disadvantage of Stream Mode is that there is a significant amount of overhead required from the MCU to process outgoing data on a word-by-word basis.

NOTE

Once a TX sequence is started, it is best not to abort it. Wait for the `tx_sent_irq` status and interrupt. If the TX sequence must be aborted, it is best practice to reset the transceiver.

The following is a typical sequence for stream transmit operation not using a timer-based start (note that `xcvr_seq[1:0]` field = 00):

1. The TX frequency must be programmed.
2. If not already low, the MCU sets RXTXEN low.
3. TX control bits must be programmed (Stream Mode and no timer):
 - a) `tmr_trig_en` = 0
 - b) `use_strm_mode` = 1
 - c) `rx_strm` = 0
4. Program `gpio_alt_en` = 1 to enable GPIO1 as an “out-of_idle” indicator and GPIO2 as a CRC “valid” indicator.
5. `tx_sent_mask`, Control_A Register 06, Bit 9 is programmed to “1” to enable an interrupt request when a word of TX payload data needs to be written.
6. `tx_done_mask`, Control_B Register 07, Bit 7 is programmed to “1” to enable an interrupt request when the TX packet has been fully sent.
7. The MCU loads the value of the number of data bytes plus two (for FCS) into `tx_pkt_length[6:0]` TX_Pkt_Ctl Register 03, Bits 6 - 0.
8. The MCU preloads the first data word into TX_Pkt_RAM Register 02
9. `tx_strm`, Control_A Register 06, Bit 12 is programmed to “1” to enable the stream TX sequence.
10. RXTXEN must be asserted and held high.
11. The transmitter will turn-on, send preamble, the SFD, the FLI, and the first data word. When the transceiver is ready to accept another data word, the `tx_sent_irq`, IRQ_Status Register 24, Bit 6, will go valid and generate an interrupt request asking for the next word of payload data.
12. The microcontroller must respond to the interrupt by writing the TX data to `tx_pkt_ram[15:0]` TX_Pkt_RAM Register 02.

NOTE

Steps 11 and 12 get repeated as required for the payload data. A word must be transferred within 64 μ s to keep the packet contiguous. No data transfer is required for the FCS data because it is generated by the onboard transceiver.

13. When the payload data packet has been successfully transmitted followed by the CRC bytes, the MC13192 will generate a tx_done_irq, IRQ_Status Register 24, Bit 14 that reports the completion of packet transmission, where a “1” indicate complete status. Also, an interrupt is generated due to the valid status.
14. In response of the interrupt request from the MC13192, the microcontroller checks status to clear the interrupt and check the validity of the TX complete.

6.3.5 Clear Channel Assessment (CCA) Modes (including Link Quality Indication)

A special case of receive function called Clear Channel Assessment (CCA) modes is available to measure received energy from the selected channel. The CCA function exists as two algorithms:

1. Clear channel assessment - measuring channel energy and comparing to a preset threshold.
2. Energy detect (ED) - measuring channel energy and giving an indication of measured strength.

The energy detect algorithm is also used for Link Quality Indication (LQI) during a normal RX operation. The LQI is reported as part of the RX operation.

The CCA modes are associated with the following register fields:

1. cca_type[1:0], Control_A Register 06, Bits 5 - 4, determines channel energy assessment algorithm where value 0x1 selects CCA and value 0x2 selects energy detect.
2. cca_vt[7:0], CCA_Thresh Register 04, Bits 15 - 8, sets the threshold level for the CCA function.
3. The average power of the signal is displayed in field cca_final[7:0], RX_Pkt_Latch Register 2D, Bits 15 - 8. This field is used for CCA, ED, and as LQI during an RX operation.
4. power_comp[7:0], CCA_Thresh Register 04, Bits 7-0, provides an offset that is added to the measured value of the average energy from a CCA/ED function or LQI value from an RX function.
5. Status bit cca, IRQ_Status Register 24, Bit 1, is used only for the CCA algorithm and is set to “1” when a busy channel is detected.
6. Status bit cca_irq_status, IRQ_Status Register 24, Bit 5, is set to “1” when the power measurement is complete for CCA or ED. If cca_mask, Control_A Register 06, Bit 10, is set an interrupt request will be also generated when the cca_irq_status is set.
7. For CCA Mode, it is preferred that tx_strm, rx_strm and use_strm_mode control bits should be cleared to zero.

6.3.5.1 Clear Channel Assessment Function (use_strm is zero)

The CCA function measures the average energy of the channel and compares it to a preset threshold as required by the 802.15.4 Standard. In CCA mode, the receiver first warms-up from Idle in 144 μ s. The average value of the signal power, as measured over the next 128 μ s (8 symbol periods), is calculated and stored in cca_final[7:0].

To determine the decimal equivalent of the value stored in `cca_final[7:0]`, one must convert the hex value to its decimal value, divide by two, and change the sign; where this calculated value is equivalent to the received signal strength in dBm:

$$\text{Signal strength in dBm} = - (\text{dec} (\text{cca_final}[7:0] / 2))$$

The value stored in `cca_final[7:0]` is also affected by an offset stored in `power_comp[7:0]`, CCA_Thresh Register 04, Bits 7-0. The default value of `power_comp[7:0] = 0x8D` and is added to the measured value of during the CCA/ED/LQI function to give the stored value in `cca_final[7:0]`.

The compensation number added to the internal measured value is `power_comp[7:0] / 2` and the resulting addition is shown in Figure 6-5.

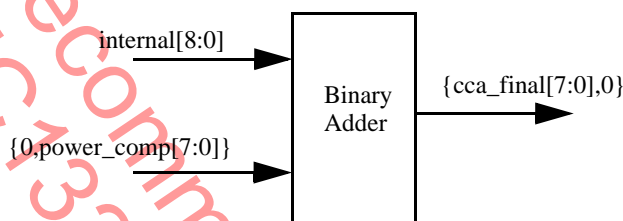

Figure 6-5. Compensation factor added to internal CCA value to produced corrected final value

The resulting formula for dBm means that the `power_comp[7:0]` value must be incremented or decremented by 4 to cause a 1 dBm change, which equates to a 1/4 dBm resolution for the `power_comp` correction.

The resulting formula for dBm means that the `power_comp[7:0]` value must be incremented or decremented by 4 to cause a 1 dBm change, which equates to a 1/4 dBm resolution for the `power_comp` correction.

.The `power_comp[7:0]` default value is `0x8D` and the value must be incremented to set a lower final CCA value. As an example, if one were putting in -30 dBm signal and the `cca_final[7:0]` was reporting -26 dBm, then the correction value in `power_comp[7:0]` should be increased by $(4 * \text{delta})$ or $(4 * 4)$ in this case. The new compensated value of `power_comp[7:0] = 0x8D + 0x10 = 0x9D`.

Since the AGC is set to a fixed gain during the CCA procedure, input signals above -65 dBm will not be reflected correctly due to saturation. This is not a problem since the purpose of this measurement is to detect a signal above a threshold that is not to exceed -75 dBm. See the 802.15.4 Standard for details.

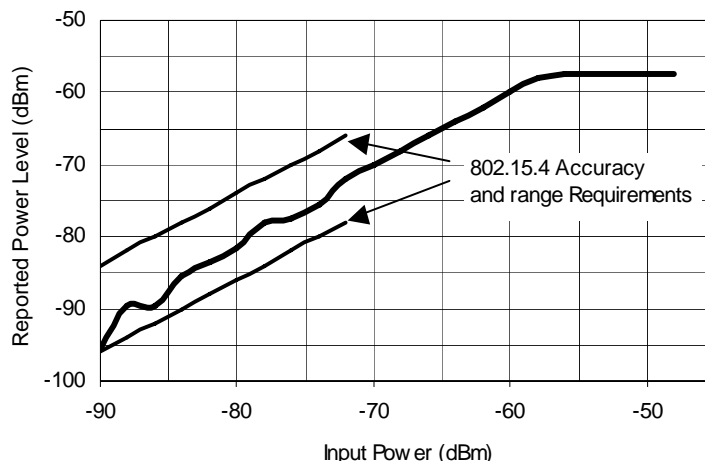

Figure 6-6. CCA Reported Power Level vs. Input Power

The value contained in `cca_final[7:0]`, is compared to the preset threshold of `cca_vt[7:0]`, CCA_Thresh Register 04, Bits 15 - 8. If `cca_final[7:0]` is equal to or less than the threshold, then `cca` is set to 1, indicating a busy channel. If `cca_final[7:0]` is greater than the threshold, `cca` remains at 0. Once the CCA operation is complete, `cca_irq` is asserted.

The value of `cca_vt[7:0]` is calculated:

$$\text{Threshold value} = \text{hex} (| (\text{Threshold Power in dBm}) * 2 |)$$

A suggested threshold is -82 dBm or `0xA4 = cca_vt[7:0]`.

The following is a typical sequence for CCA operation (not using a timer-based start):

NOTE

The control bit `use_strm_mode`, Control_B Register 07, Bit 5 should be set to “0”.

1. The RX frequency must be programmed.
2. If not already low, the MCU sets RXTXEN low.
3. The CCA threshold must be programmed (`cca_vt[7:0] = 0xA4` as an example).
4. `cca_mask`, Control_A Register 06, Bit 10 is programmed to “1” to enable an interrupt request when the CCA operation is complete.
5. `cca_type[1:0]`, Control_A Register 06, Bits 5 - 4, is programmed to “01” to select the CCA algorithm.
6. Transceiver sequence is programmed to `xcvr_seq[1:0] = 0x1` for CCA mode.
7. RXTXEN must be asserted and held high.
8. When the measurement is complete, the following are reported:
 - a) `cca_final[7:0]`, RX_Pkt_Latch Register 2D, Bits 15 - 8 - reports the average power level
 - b) `cca`, IRQ_Status Register 24, Bit 1, is set to “1” when a busy channel is detected

- c) `cca_irq`, IRQ_Status Register 24, Bit 5, is set to “1” to indicate complete status. Also, an interrupt is generated due to the valid status
- 9. In response of the interrupt request from the MC13192, the microcontroller does the following:
 - a) Determines the busy status of the channel by reading and checking `cca_irq` and `cca`
 - b) If required the power level can be determined by reading `cca_final[7:0]`
- 10. Negate `TXTXEN` to low.

6.3.5.2 Energy Detect Function (use_strm is zero)

With the energy detect algorithm, the exact same procedure results as the CCA operation without the threshold comparison. The receiver warms-up from Idle in 144 μ s and the received power is measured over the next 128 μ s (8 symbol periods). The average power is calculated and stored in `cca_final[7:0]`.

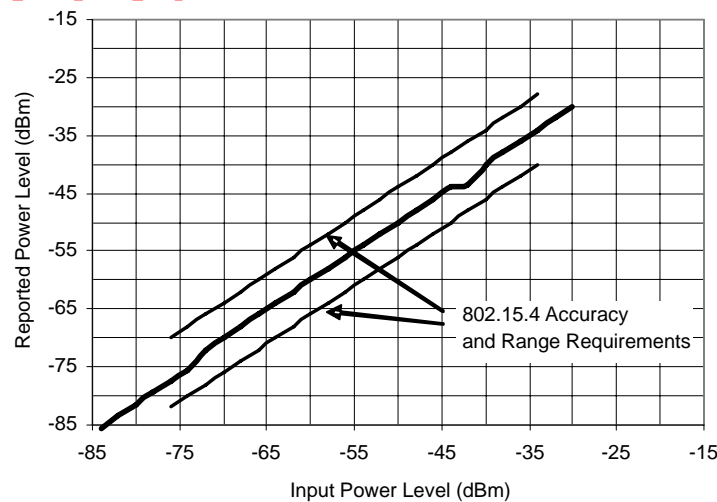

Figure 6-7. ED and LQI Reported Power vs. Input Power

Status bit `cca` is unaffected by energy detect. Once the energy detect operation is complete, `cca_irq` is asserted.

The following is a typical sequence for ED operation (not using a timer-based start):

NOTE

The control bit `use_strm_mode`, Control_B Register 07, Bit 5 should be set to “0”.

1. The RX frequency must be programmed.
2. If not already low, the MCU sets `RXTXEN` low.
3. `cca_mask`, Control_A Register 06, Bit 10 is programmed to “1” to enable an interrupt request when the CCA operation is complete.
4. `cca_type[1:0]`, Control_A Register 06, Bits 5 - 4, is programmed to “10” to select the ED algorithm.
5. Transceiver sequence is programmed to `xcvr_seq[1:0] = 0x1` for CCA mode.
6. `RXTXEN` must be asserted and held high.

7. When the measurement is complete, the following are reported:
 - a) `cca_final[7:0]`, RX_Pkt_Latch Register 2D, Bits 15 - 8 - reports the average power level
 - b) `cca_irq`, IRQ_Status Register 24, Bit 5, is set to “1” to indicate complete status. Also, an interrupt is generated due to the valid status
8. In response of the interrupt request from the MC13192, the microcontroller can determine the power level by reading `cca_final[7:0]`.
9. Negate `RXTXEN` to low.

6.3.5.3 CCA / ED While in Stream Mode (`use_strm` is one)

It is recommended that a CCA or ED operation be performed while `use_strm` control bit is not active. However, for software timing considerations, there are times that it may be desirable to leave `use_stream` active and a CCA/ED can be done through an alternate procedure.

The CCA / ED operation is done in a manner similar to that described in the previous two Sections. However, before asserting `RXTXEN` (starting the sequence), the MCU should write Register 38 to the value `0x01FF`. This register value should only be used for the CCA or ED operation and not for an RX operation. The default value of `0x0008` should be written to Register 38 be initiating an RX operation.

6.3.5.4 Link Quality Indication

Link Quality Indication is a measure of the signal quality during an actual receive operation. Its value is stored in field `cca_final[7:0]`, RX_Pkt_Latch Register 2D, Bits 15 - 8. In Stream Mode, note that LQI is valid and can be fetched with the same read as when fetching `rx_pkt_latch[6:0]`.

The format for the LQI is the same as CCA:

$$\text{Signal strength in dBm} = - (\text{dec} (\text{cca_final}[7:0] / 2))$$

NOTE

Typical values of LQI returned from an RX operation are from about -95 dBm to about -18 dBm giving a `cca_final[7:0]` range of decimal values 190 (0xBE) to 36 (0x24). When used in an 802.15.4 application, the LQI must be scaled and limited to have a range of decimal 0 to 255. Values of LQI above approximately -30 to -25 dBm can be non-linear and should not be used as an indication of absolute received power.

6.4 Frequency of Operation

The MC13192 is designed to operate in the 2.4 GHz band, covering 16 channels and using 5 MHz of spacing between each channel. The MC13192 uses two local oscillators (LO). The first LO synthesizer is the main LO for the receiver and the carrier generator for the transmitter. This block is comprised of a Fractional-N (Frac-N) PLL frequency synthesizer.

The fractional and integer components of the Frac-N must be programmed properly to perform a transceiver operation on a particular channel. The channels and the respective, required bit values of the

integer setting are shown in the LO1_Int_Div Register 0F, Bits 7-0 (lo1_idiv[7:0]) and the fractional setting are shown in LO1_Num Register 10 (lo1_num[15:0]). See [Table 4-17](#).

6.5 Transmit Power Adjustment

[Table 6-3](#) shows the device power output versus SPI register settings for pa_lvl_course[1:0], PA_Lvl Register 12, Bits 7-6 and pa_lvl_fine[1:0], PA_Lvl Register 12, Bits 5-4.

Table 6-3. MC13192 Power Output vs. SPI Settings (Register 12)

PA Power Adjust Reg 12[7:0] (Hex)	Typical Differential Power at Output Contact (dBm)	Typical PA Current (mA)	Comments
00	-28.7	20.9	
04	-22.0	21.7	
08	-18.5	22.9	
0C	-16.2	25.0	Reg 12[3:0] default
1C	-15.9	25.1	Reg 12[3:0] default
2C	-15.3	25.1	Reg 12[3:0] default
3C	-14.8	25.1	Reg 12[3:0] default
4C	-8.5	25.9	Reg 12[3:0] default
5C	-7.6	26.0	Reg 12[3:0] default
6C	-7.2	26.1	Reg 12[3:0] default
7C	-7.0	26.2	Reg 12[3:0] default
8C	-1.7	28.0	Reg 12[3:0] default
9C	-1.6	28.3	Reg 12[3:0] default
AC	-0.77	28.6	Reg 12[3:0] default
BC (default)	-0.66	28.8	Reg 12[7:0] default
CC	0.62	30.6	Reg 12[3:0] default
DC	1.19	31.9	Reg 12[3:0] default
EC	1.23	34.9	Reg 12[3:0] default
FC	1.42	35.3	Reg 12[3:0] default
FD	2.2	35.0	
FE	2.9	35.0	
FF	3.4	35.0	

6.6 2.4GHz PLL Out-of-Lock Interrupt

Successful wireless data transmission and reception is predicated on the proper channel frequency being maintained internally by the MC13192. Sophisticated control circuitry and design techniques assure that the internal 2.4GHz local oscillator stays on the selected channel frequency. In the unusual event that the PLL loses lock, the host is notified via the 'Out-of-Lock Interrupt'. If lock indication circuitry indicates an out-of-lock condition, status bit `pll_lock_irq`, `IRQ_Status` Register 24, Bit 15, is set and any RX or TX operation in progress is automatically terminated. The MC13192 returns immediately to the IDLE state to await interrupt service routine handling. Also, the $\overline{\text{IRQ}}$ is asserted provided the mask bit `pll_lock_mask`, `IRQ_Mask` Register 05, Bit 9, is set.

NOTE

It is recommended that software enable the `pll_lock_mask` during CCA, RX, and TX operations. The `pll_lock_irq` status bit will get set by an out-of-lock condition and MUST be cleared by an `IRQ_Status` Register read before another CCA, RX, or TX operation can be enabled. As stated above an out-of-lock condition will abort the present operation and if the `pll_lock_irq` status is not cleared, any subsequent CCA, RX, or TX operation requested will be immediately aborted.

Examples of where this could be troublesome is in Packet Mode RX or a CCA operation. If the RX or CCA is aborted due to an out-of-lock condition, no `rx_done_irq` status or `cca_irq` status will be set and a corresponding IRQ signal will not be asserted, and as a result, no interrupt will be generated unless the `pll_lock_irq` is enabled to generate an interrupt.

Chapter 7

Timer Information

7.1 Event Timer Block

The MC13192 contains an internal Event Timer block that manages system timing. A simplified block diagram is shown in Figure 7-1.

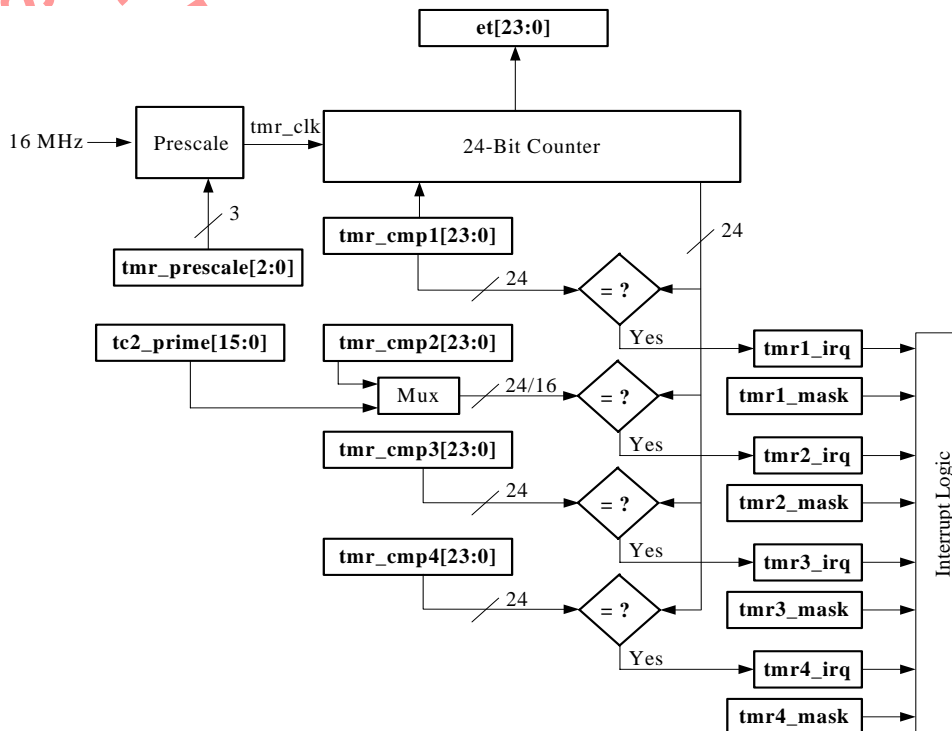

Figure 7-1. Event Timer Block Diagram

The Event Timer consists of a prescaler and a 24-bit counter which increment whenever the crystal clock is operating. Interrupts to the MCU may be generated when the “current time” of the counter (et[23:0]) matches several pre-determined values set in registers via SPI write operations. The current time is accessible at any time via a SPI read operation, as well as, programmable via a SPI write operation. The Event Timer provides the following functions:

- Timer to generate current system time
- Interrupt generation at pre-determined system times
- Exit from Doze mode at pre-determined system time
- Latches “timestamp” value during packet reception
- Initiates timer-triggered sequences

7.2 Event Timer Time Base

The Event Timer’s base clock (tmr_clk) is derived from a programmable prescaler which is clocked by the 16 MHz crystal source. The prescaler provides counter input frequencies from 2 MHz down to 15.625 kHz, which sets the granularity and resolution of the current time. The prescaler, and thus the Event Timer only increment when the crystal oscillator is active. The field tmr_prescale[2:0] Control_C Register 9, Bits 2-0 (Section 4.13) establishes the tmr_clk frequency as shown in Table 7-1.

Table 7-1. Event Timer Prescaler Settings

Register 9, Bits 2-0 tmr_prescale [2:0]	Event Timer Time Base	Maximum Event Timer Duration
000	2 MHz	8.389 seconds
001	1 MHz	16.777 seconds
010	500 kHz	33.554 seconds
011 (default)	250 kHz	67.109 seconds
100	125 kHz	134.218 seconds
101	62.5 kHz	268.436 seconds
110	31.25 kHz	536.871 seconds
111	15.625 kHz	1073.742 seconds

The 24-bit counter automatically rolls over upon reaching its maximum value, and the corresponding maximum possible Event Timer durations are also provided in Table 7-1.

7.3 Setting Current Time

“Current Time” is defined as the value of the Event Timer internal counter. The current time is programmable, but does not have to be programmed. In the reset condition, the MC13192 current time is set to zero. Current time advances from zero at the tmr_clk clock rate and rolls over to zero after reaching its maximum value.

Programming “current time” is accomplished by using three SPI registers:

1. Tmr_Cmp1_A Register 1B, Bits 7-0, tmr_cmp1[23:16]
2. Tmr_Cmp1_B Register 1C, Bits 15-0, tmr_cmp1[15:0]
3. Control_B Register 07, Bit 15, tmr_load

When field tmr_load is programmed to high, the value of “current time” is set to the value in tmr_cmp1[23:0]. Thus, tmr_cmp1[23:0] is first programmed to the desired current time value, then tmr_load is programmed to 1, which initiates the timer load. The change to the “current time” value occurs within two crystal clock cycles, after which normal incrementing resumes on the next rising tmr_clk edge. So, tmr_load is not required to be programmed to zero for the Event Timer to resume normal operation. However, loading the Event Timer is a positive edge-triggered event, so tmr_load must be programmed low prior to the next attempt to load the Event Timer.

7.4 Reading Current Time

The current value of the Event Timer can be read via the SPI using `et[23:16]`, `Current_Time_A` Register 26, Bits 7-0, and `et[15:0]`, `Current_Time_B` Register 27, Bits 15-0. The “current time” may be obtained using two single SPI reads, or one recursive 2-word SPI read (or as part of a longer recursive read operation as well). It is important to realize that the Event Timer may increment during these recursive SPI read operations, or between successive SPI reads if single SPI reads are used. During such an access, the MC13192 latches the “current time” to protect the host from obtaining an incorrect value. The “current time” least significant 16 bits (LSB) are latched when the most significant 8 bits (MSB) SPI location is read. The LSB is unlatched after the “current time” LSB location is read. This guarantees a stable value until the host completes a read of both words constituting the “current time” before it is allowed to update.

The preferred procedure to obtain the “current time” value from the MC13192 is to perform a 2-word recursive read of the “current time” starting at the MSB address.

7.5 Latching the Timestamp

The MC13192 has the ability create a Timestamp or to latch a copy of the “current time” while continuing to increment its internal counter. This timestamp value latched within the Event Timer corresponds to the beginning of a receive packet where the actual payload data begins after the FLI has been received. The `timestamp[23:0]` (Register 2E, Bits 7-0 and Register 2F, bits 15-0) value is read from the MC13192 by the host. When `timestamp[23:0]` is latched, its value corresponds to the “current time” value coincident with the reception of `rx_pkt_latch[6:0]`, `RX_Pkt_Latch` Register 2D, Bits 6-0. The timestamp remains latched until another packet is received, at which point the `timestamp[23:0]` value is updated and re-latched.

7.6 Event Timer Comparators

The MC13192 incorporates four full 24-bit programmable fields that compare to the Event Timer’s “current time”. The intent of these compares is to enable the host to schedule events relative to the “current time”. When a match between the “current time” and any one of the four timer compare values occurs, a corresponding flag is sent to internal interrupt logic. This causes the appropriate bit in the `IRQ_Status` Register 24 to be set, and depending on the interrupt mask control bit, generate an interrupt event on the IRQ pin.

7.6.1 Timer Compare Fields

There are four 24-bit timer compare fields:

1. `tmr_cmp1[23:0]`, `Tmr_Cmp1_A` Register 1B, Bits 7-0, and `Tmr_Cmp1_B` Register 1C, Bits 15-0.
2. `tmr_cmp2[23:0]`, `Tmr_Cmp2_A` Register 1D, Bits 7-0, and `Tmr_Cmp2_B` Register 1E, Bits 15-0.
3. `tmr_cmp3[23:0]`, `Tmr_Cmp3_A` Register 1F, Bits 7-0, and `Tmr_Cmp3_B` Register 20, Bits 15-0.
4. `tmr_cmp4[23:0]`, `Tmr_Cmp4_A` Register 21, Bits 7-0, and `Tmr_Cmp4_B` Register 22, Bits 15-0.

And a special case 16-bit timer compare field for stream data mode:

1. `tc2_prime[15:0]`, `TC2_Prime` Register 23, Bits 15-0.

7.6.2 Timer Disable Bits

Each timer comparator has a disable bit that enables or disables the compare function. The disable bit is written to a “1” to disable the corresponding comparator and the default condition is the timer enabled (reset to “0”):

1. `tmr_cmp1_dis`, `Tmr_Cmp1_A` Register 1B, Bit 15.
2. `tmr_cmp2_dis`, `Tmr_Cmp2_A` Register 1D, Bit 15.
3. `tmr_cmp3_dis`, `Tmr_Cmp3_A` Register 1F, Bit 15.
4. `tmr_cmp4_dis`, `Tmr_Cmp4_A` Register 21, Bit 15.

If a timer comparator is disabled using its associated bit, the corresponding status bit (`tmrx_irq`) will also be cleared if set and will negate an associated interrupt.

7.6.3 Timer Status Flags

When enabled, all four fields can be continuously compared to the current value of the Event Timer counter. When a match occurs, the following corresponding internal status flags assert:

1. `tmr1_irq`, `IRQ_Status` Register 24, Bit 8.
2. `tmr2_irq`, `IRQ_Status` Register 24, Bit 2.
3. `tmr3_irq`, `IRQ_Status` Register 24, Bit 4.
4. `tmr4_irq`, `IRQ_Status` Register 24, Bit 3.

The status bit remains set until a read access of the `IRQ_Status` register occurs or if the timer comparator disable bit is set to disable an active comparator.

7.6.4 Timer Interrupt Masks

When a comparator match occurs and the internal status flag asserts, the following interrupt masks can enable an interrupt on the `IRQ` pin:

1. `tmr1_mask`, `IRQ_Mask` Register 05, Bit 0.
2. `tmr2_mask`, `IRQ_Mask` Register 05, Bit 1.
3. `tmr3_mask`, `IRQ_Mask` Register 05, Bit 2.
4. `tmr4_mask`, `IRQ_Mask` Register 05, Bit 3.

If the interrupt mask is set to “1” (enabled), the timer compare status will cause an interrupt and the interrupt signal will stay active until the status bit is cleared via an `IRQ_Status` read.

7.6.5 Setting Compare Values

Since the primary timer compare fields are 24-bit values, they are each shared between two sequential SPI register addresses. The timer compare value can be changed using two single SPI writes, or one recursive 2-word SPI write (or as part of a longer recursive write operation as well).

NOTE

It is important to realize that not all bits of the timer compare value are updated simultaneously within the SPI. To prevent the Event Timer from generating a false match to a partially updated timer compare value, the compare hardware is inhibited temporarily. The inhibit feature initiates when the address of the MSB location of the timer compare field is decoded on a SPI write, and ends when a write to the LSB field is completed. Thus, once an SPI write to the MSB location starts, the comparator is disabled until an SPI write to the LSB location is completed. The preferred procedure for software to change a timer compare value within the MC13192 is to perform a 2-word recursive write of the timer compare field starting at the MSB address.

7.7 Intended Event Timer Usage

It is intended that the system utilize the “current time” value and the timer compare functions of the Event Timer to schedule system events, including:

- Generating time-based interrupts
- Exiting Doze mode
- Triggering transceiver operations

NOTE

The timer_compare functions exit reset with the timer function enabled but with the interrupts masked off. Users should disable all timers and clear the IRQ_Status Register via a read as part of system initialization after reset.

7.7.1 Generating Time-Based Interrupts

Generating time-based interrupts is accomplished by setting timer compare values relative to the “current time”, allowing the Event Timer counter to increment until a timer compare match is generated, and using this match to generate an interrupt to the host. The general procedure is as follows:

1. Disable the timer compare. This clears the status flag if already set.
2. Enable the timer compare interrupt mask.
3. Read the “current time” value from et[23:0].
4. Add an offset to this value to equal desired “future time”.
5. Program the appropriate timer_compare value to “future time”.
6. Program the appropriate tmr_cmpx_dis bit to enable the compare.

Timer Information

7. Allow a timer compare match to set the status register bit and generate an interrupt. The appropriate internal status register bit is always set upon a timer_compare match. An external interrupt is generated when the corresponding SPI interrupt mask bit, Register 5, Bits 3, 2, 1, or 0, is set.
8. Program the appropriate tmr_cmpx_dis bit to disable the compare function. If this is not done, the compare function will continue to run and generate another interrupt every time the counter rolls over and again matches the comparator.

7.7.2 Using tmr_cmp2[23:0] to Exit Doze Mode

The Event Timer provides a timer-based mechanism to bring the MC13192 out of Doze mode. The MC13192 is put into Doze mode when doze_en, Control_B Register 07, Bit 0, is programmed high. While in Doze mode, a match between “current time” and field tmr_cmp2[23:0] causes the MC13192 to exit Doze mode and return to Idle Mode.

The general procedure is as follows:

1. Read the “current time” value from et[23:0].
2. Add an offset to this value to equal desired “future time” to exit Doze mode.
3. Program field tmr_cmp2[23:0] to value “future time”.
4. Program doze_mask, Register 05, Bit 4, to 1.
5. Program doze_en, Register 7, Bit 0, to 1. The MC13192 then enters Doze mode. (Note that the control bit tmr_cmp2_dis has no effect on this mode).
6. When “current time” equals tmr_cmp2[23:0], the MC13192 exits Doze mode, and doze_irq, Register 24, Bit 9, gets set. An external interrupt is also generated because doze_mask is set.

NOTE

The MC13192 can always be taken out of Doze Mode by asserting \overline{ATTN} or \overline{RST} . Also, if acom_en IRQ_Mask Register 05, Bit 8 is set before entering Doze mode, the Event Timer logic is disabled for additional power savings and only \overline{ATTN} or \overline{RST} will cause exit of Doze mode.

7.7.3 Timer-Triggered Transceiver Events

An Event Timer can be used to initiate the MC13192 transceiver operations such as transmit and receive. The desired operation can be scheduled to commence at a future time greater than the “current time” by using the MC13192 timer-triggered operation capability. Timer-triggered operations are invoked by using either by tmr_cmp2 [23:0] for Packet Mode operations or tc2_prime[15:0] for Stream Mode operations. A time greater than the “current time” is programmed into the appropriate compare field and tmr_trig_en, Control_A Register 6, Bit 7 is programmed high. When the “current time” advances to match the value set in the compare field, the selected operation sequence will commence automatically without intervention from the host. This allows the host to arm the MC13192 to execute a desired operation at a future time, and go off to perform other necessary system functions.

7.7.3.1 Packet Mode Timer_Triggered TX or RX Events

In Packet Mode only `tmr_cmp2` [23:0] can be used to initiate a transceiver event. The general procedure is as follows:

1. Desired frequency must be programmed.
2. If not already low, the MCU sets RXTXEN low.
3. Stream Mode `rx_strm`, `tx_strm`, and `use_strm_mode` control bits must be cleared.
4. Read the “current time” value from `et`[23:0].
5. Add an offset to this value to equal desired “future time” to initiate selected operation.
6. Program field `tmr_cmp2`[23:0] to value “future time”.
7. Program `tmr_cmp2_dis` to 0 to enable the compare function.
8. If desired, program `tmr2_mask`, IRQ_Mask Register 05, Bit 1 high to enable an interrupt when the timer compare function completes and starts the transceiver.
9. For a TX operation only, load `tx_pkt_length`[6:0] and payload data into `tx_pkt_RAM`[15:0].
10. Program `tmr_trig_en`, Control_A Register 6, Bit 7 high to enable a timer-based operation.
11. Program the MC13192 for the desired transceiver operation via `xcvr_seq`[1:0].
12. Assert the RXTXEN pin and hold high.
13. When “current time” equals `tmr_cmp2`[23:0], the MC13192 initiates the selected transceiver operation. When `tmr2_irq`, IRQ_Status Register 24, Bit 2 is set to 1, an external interrupt is generated if the interrupt mask bit (`tmr2_mask`) was set high.

NOTE

`tmr_trig_en` is level sensitive. It is not necessary to program it to 0 prior to the next timer triggered operation.

14. Once started, the transceiver operation commences in a normal manner.

7.7.3.2 Stream Mode Timer_Triggered TX or RX Events

In Stream Mode, `tc2_prime`[15:0] is used in place of `tmr_cmp2` [23:0] to initiate a transceiver event. The `tmr_cmp2_dis` bit must be enabled as allows `tc2_prime`[15:0] to function. The general procedure is as follows:

1. Desired frequency must be programmed.
2. If not already low, the MCU sets RXTXEN low.
3. Packet Mode `xcvr_seq`[1:0] field should be cleared.
4. Read the “current time” value from `et`[23:0].
5. Add an offset to this value to equal desired “future time” to initiate selected operation. Note that only the lowest 16 bits are used with `tc2_prime`[15:0].
6. Program field `tc2_prime`[15:0] to value “future time”.
7. If desired, program `tmr2_mask`, IRQ_Mask Register 05, Bit 1 high to enable an interrupt when the timer compare function completes and starts the transceiver.

Timer Information

8. For a TX operation only, load tx_pkt_length[6:0] and first word of payload data into tx_pkt_RAM[15:0].
9. Enable tmr_cmp2_dis by programming to low.
10. Program tmr_trig_en, Control_A Register 6, Bit 7 high to enable a timer-based operation.
11. Program use_strm_mode bit high for stream data mode.
12. Program either rx_strm or tx_strm for desired operation.
13. Assert the RXTXEN pin and hold high.
14. When “current time” equals tc2_prime[15:0], the MC13192 initiates the selected transceiver operation. When tmr2_irq, IRQ_Status Register 24, Bit 2 is set to 1, an external interrupt is generated if the interrupt mask bit (tmr2_mask) was set high.

NOTE

tmr_trig_en is level sensitive. It is not necessary to program it to 0 prior to the next timer triggered operation.

15. Once started, the transceiver operation commences in a normal manner.

Chapter 8

Interrupt Description

8.1 Interrupts

Interrupts provide a way for the MC13192 to inform the host microcontroller (MCU) of onboard events without requiring the MCU to constantly query MC13192 status.

For a given event, the interrupt flow is as follows.

- The source interrupt mask is enabled.
- The source function is enabled.
- The source event occurs causing the source status flag to be set and the $\overline{\text{IRQ}}$ pin to be asserted low.
- The $\overline{\text{IRQ}}$ pin stays asserted until the $\overline{\text{IRQ}}$ _Status Register is read to determine the source of the interrupt. Reading the $\overline{\text{IRQ}}$ _Status Register clears the status bits and releases the $\overline{\text{IRQ}}$ signal to be negated high.

When multiple source events have occurred, the MCU must use the $\overline{\text{IRQ}}$ _Status register contents to determine all the present events that caused an interrupt, prioritize them, and respond to all of the them. This is done through the interrupt service routine of the MCU.

8.1.1 Interrupt Sources

Table 8-1 lists the interrupt status bits, mask bits, and source description.

Table 8-1. MC13192 Interrupt Sources

Item	Status Bit	Mask Bit	Source Description	Interrupt Clear Mechanism ¹
1	pll_lock_irq	pll_lock_mask	PLL out of lock.	Read IRQ_Status Reg
2	ram_addr_err / tx_done_irq	ram_addr_mask / tx_done_mask	<ol style="list-style-type: none"> 1. RAM address error - When in packet data mode, a recursive access to Packet RAM has exceeded the maximum RAM address. The ram_addr_mask controls the interrupt generation for this mode. 2. TX Done - When in streaming data mode, the TX operation is complete and transceiver has returned to Idle Mode. The tx_done_mask controls interrupt generation in this mode. 	Read IRQ_Status Reg (for either mode)
3	arb_busy_err / rx_done_irq	arb_busy_mask / rx_done_mask	<ol style="list-style-type: none"> 1. Arbitration busy error - When in packet data mode, a SPI access to Packet RAM was attempted during packet reception or transmission. The arb_busy_mask controls the interrupt generation for this mode. 2. RX Done - When in streaming data mode, the RX reception is complete and the transceiver has returned to Idle Mode. The rx_done_mask controls interrupt generation in this mode. 	Read IRQ_Status Reg (for either mode)
4	strm_data_err	strm_data_mask	<ol style="list-style-type: none"> 1. For RX stream data mode, a new received data word has been received before the previous RX data word was read (this is a data overrun condition). 2. For TX stream data mode, the current TX data word transmission was complete before next TX data word was written (this is a data underrun condition). 	Read IRQ_Status Reg
5	attn_irq	attn_mask	The $\overline{\text{ATTN}}$ signal has been asserted or the MC13192 has reached a Power-up complete condition after a reset.	Read IRQ_Status Reg
6	doze_irq	doze_mask	While in Doze mode, a tmr_cmp2 match has occurred and the MC13192 will return to Idle mode.	Read IRQ_Status Reg
7	rx_rcvd_irq / rx_strm_irq	rx_rcvd_mask	<ol style="list-style-type: none"> 1. Rx_rcvd_irq - When in packet data mode, the current RX packet has been received, data in Packet RAM is ready to be read, and the transceiver has returned to Idle Mode. 2. Rx_strm_irq - When in streaming data mode, a data word is ready to be read: <ol style="list-style-type: none"> a) First occurrence - RX Packet Length is available to be read. b) Subsequent occurrences - next RX stream data word is ready to be read 	<ol style="list-style-type: none"> 1. Read IRQ_Status Reg 2a) First occurrence - read RX Packet Length from Register 2D 2b) Subsequent occurrences - read RX data word from Register 01

Table 8-1. MC13192 Interrupt Sources (continued)

Item	Status Bit	Mask Bit	Source Description	Interrupt Clear Mechanism ¹
8	tx_sent_irq/ tx_strm_irq	tx_sent_mask	1. Tx_sent_irq - When in packet data mode, the current TX packet in Packet RAM has been completely transmitted, and the transceiver has returned to Idle Mode. 2. Tx_strm_irq - When streaming data mode, transceiver is ready for next TX data word to be written.	1. Read IRQ_Status Reg 2. Write TX data to Register 02
9	cca_irq	cca_mask	The Clear Channel Assessment operation has been completed.	Read IRQ_Status Reg
10	tmr1_irq	tmr1_mask	Tmr_cmp1 match has been made.	Read IRQ_Status Reg or set tmr_cmp1_dis bit
11	tmr2_irq	tmr2_mask	Tmr_cmp2 or tc2_prime match has been made. (Not functional when Tmr_cmp2 is used to exit Doze Mode)	Read IRQ_Status Reg or set tmr_cmp2_dis bit
12	tmr3_irq	tmr3_mask	Tmr_cmp3 match has been made.	Read IRQ_Status Reg or set tmr_cmp3_dis bit
13	tmr4_irq	tmr4_mask	Tmr_cmp4 match has been made.	Read IRQ_Status Reg or set tmr_cmp4_dis bit

¹ Although some status bits can be cleared by other means, reading IRQ_Status register will always clear all status bits.

8.1.2 Output Pin $\overline{\text{IRQ}}$

The $\overline{\text{IRQ}}$ signal is an open drain output that is asserted low when an interrupt request is pending. The signal is released to high by reading the IRQ_Status register via an SPI transaction. $\overline{\text{IRQ}}$ is an open drain output that requires a passive pullup and it also can be programmed for drive strength.

8.1.2.1 Programming $\overline{\text{IRQ}}$ Pullup

A passive pullup is required on $\overline{\text{IRQ}}$ and may be done via two methods:

1. Use the onboard (nominal 40 Kohm) pullup resistor - Set irqb_pup_en bit, GPIO_Data_Out Register 0C, Bit 7, to activate. This is the default mode.
2. Use an external resistor (value should be greater than 4 kilohms).

8.1.2.2 Setting $\overline{\text{IRQ}}$ Output Drive Strength

$\overline{\text{IRQ}}$ output drive strength is programmed by writing to irqb_drv[1:0], GPIO_Data_Out Register 0C. There are 4 levels of drive strength with field value 00 for lowest and value 11 for greatest. The default value is 11.

NOTE

It is suggested the user leave $\overline{\text{IRQ}}$ at greatest drive strength for best performance.

8.2 PLL_lock_irq Status Bit and Operation

As described in [Section 4.29, “IRQ_Status - Register 24”](#), pll_lock_irq status bit indicates the LO1 PLL has come out of lock during a TX, RX, or CCA (ED) transceiver operation. If the LO1 unlocks during the transceiver operation, the device returns to Idle mode, and the pll_lock_irq status bit gets set as expected. The application software must read the IRQ_Status Register 24 (clearing the pll_lock_irq status bit) before attempting any further transceiver active operations (TX, RX or CCA). If the status bit is not cleared, any subsequent active operation will abort immediately. This condition occurs because the LO1 unlock causes an operation abort and the status bit must be cleared or any follow-on operation will also abort.

The best practice is to enable the pll_lock_irq interrupt so that $\overline{\text{IRQ}}$ will be asserted if an unlock occurs.

- If the pll_lock_irq interrupt is not enabled and an LO1 unlock occurs, no rx_rcvd_irq status will be set for an RX operation nor will a cca_irq status be set for a CCA operation because the operation was aborted. As a result, an interrupt cannot be generated, and any follow-on operation will be aborted
- If the pll_lock_irq interrupt is not enabled for a TX operation and an unlock occurs, the tx_sent_irq status will be set when the TX aborts, so an interrupt can be generated. However, any follow-on operation will still be aborted if the IRQ_Status Register is not read

8.3 Attn_irq Status Bit and Interrupt Operation

As described in [Section 4.29, “IRQ_Status - Register 24”](#), attn_irq status bit indicates:

- The transceiver has achieved Idle status (full power-up) after the release of the $\overline{\text{RST}}$ signal. The default condition out of reset leaves the attn_irq interrupt request enabled, and upon the transceiver reaching Idle, the attn_irq status is set and the $\overline{\text{IRQ}}$ signal is asserted
- Signal $\overline{\text{ATTN}}$ has been asserted (normally to release the transceiver from Hibernate or Doze mode) and the transceiver has exited the low power mode. The $\overline{\text{IRQ}}$ signal will be asserted if the interrupt has not been masked. See [Section 3.10.2.2, “Asserting \$\overline{\text{ATTN}}\$ Early to Exit Hibernate or Doze Mode”](#) for abnormal behavior if $\overline{\text{ATTN}}$ is asserted too early upon entering Hibernate or Doze mode

8.4 Interrupts from Exiting Low Power Modes

The MC13192 has three low power modes and interrupt generation differs somewhat for each mode.

8.4.1 Exiting Off Mode (Reset)

The transceiver is put in reset and stays in reset (Off Mode) through the assertion of $\overline{\text{RST}}$. The initialization done at reset enables attn_mask which allows an interrupt request when attn_irq is set. One condition that sets attn_irq is when the transceiver exits reset after $\overline{\text{RST}}$ is released high. As a result, an interrupt request will always be generated by attn_irq status when reset is exited.

8.4.2 Exiting Hibernate Mode

Hibernate is normally only exited through assertion of \overline{ATTN} (obviously \overline{RST} can still override). The `attn_irq` status will be set by the assertion of \overline{ATTN} . If an interrupt is desired to signify the event, the `attn_mask` bit must be set before entering Hibernate. The interrupt request will then be generated due to the `attn_irq` being set true upon exit from Hibernate.

8.4.3 Exiting Doze Mode(s)

Doze can be exited via assertion of \overline{ATTN} or through use of `tmr_cmp2` (again reset can override). Asserting \overline{ATTN} will always cause Doze to be exited even if the timer option is enabled. If an interrupt is desired, set `attn_mask` before entering Doze which will cause the interrupt when the `attn_irq` status is set upon exiting Doze due to \overline{ATTN} .

Alternately, Doze has the option of using `tmr_cmp2` to exit, except for Acoma Mode which cannot use the timer. When `tmr_cmp2` match occurs the `doze_irq` status will be set. An interrupt request will also occur if `doze_mask` bit has been enabled.

Not Recommended for New Designs.
Use MC1320X.

Chapter 9 Miscellaneous Functions

9.1 Reset Function

The MC13192 can be placed in one of two reset conditions either through hardware input $\overline{\text{RST}}$ or by writing to Reset Register 00.

9.1.1 Input Pin $\overline{\text{RST}}$

Asserting input pin $\overline{\text{RST}}$ low places the transceiver in a complete reset condition (Off Mode and power down), and the device stays in this reset mode until $\overline{\text{RST}}$ is released high. After $\overline{\text{RST}}$ is released, the transceiver will transition to the Idle Mode within 25 milliseconds max. While in reset, all GPIO revert to inputs.

The $\overline{\text{RST}}$ pin has a programmable pullup that is on in the default condition. The pullup can be programmed to be disabled for lowest power.

9.1.2 Software Reset (Writing to Register 00)

Writing to Reset Register 00 causes a reset condition where the digital logic is reset, but the transceiver is not powered down. The device is forced to the Idle Mode and the SPI registers are all reset and forced to their default condition although all data in the Packet RAMs is retained. The reset is held as long as $\overline{\text{CE}}$ remains asserted and is released when $\overline{\text{CE}}$ is negated high.

9.1.3 Reset Indicator Bit (RST_Ind Register 25, Bit 7)

It is useful to determine if the transceiver has powered-up from a reset condition or from a low power state that was released via the $\overline{\text{ATTN}}$ signal. The reset indicator bit (reset_ind, RST_Ind Register 25, Bit 7) is cleared during a reset operation but not during a low power mode such as Doze or Hibernate. The reset_ind bit gets set by the first read of Register 25 after a reset operation and stays set until another reset operation.

When exiting reset, an interrupt is generated by attn_irq, IRQ_Status Register 24, Bit 10, (the default condition is with the interrupt mask enabled). This same interrupt can be enabled for exiting Hibernate or Doze via an $\overline{\text{ATTN}}$ assertion. As a result, the reset_ind bit can determine if the power-up condition is from the reset condition or a Doze or Hibernate condition.

After exiting reset and responding to the attn_irq interrupt, users should read Register 25 which in turn sets the reset_ind bit. Thereafter, if the transceiver is put into Doze or Hibernate and then later awakened by an $\overline{\text{ATTN}}$ assertion, the attn_irq interrupt is also used, but the reset_ind is set signifying that the chip was not reset and does not need re-initialized.

9.2 General Purpose Input/Output

The MC13192 has seven general purpose input/output (GPIO) pins (GPIO1 through GPIO7). Features include:

- CMOS logic levels with +/- 1 mA load current
- Programmable as inputs or outputs
- No programmable pullups are provided
- During reset outputs are disabled and exit reset as inputs

NOTE

Unused GPIO pins must be dealt with in one of two ways to prevent floating inputs. They first may be tied to ground via a hardware connection. If the user desires to leave the GPIO pin not hard-wired (for future use), the initialization of the transceiver should configure the unused GPIO as an output set to the low state to prevent excess current as well as a floating input. If the transceiver is held in reset for lowest power, the GPIO revert to inputs and the programming is overridden.

- Not capable of generating an interrupt
- Once programmed as an output, a GPIO keeps its state if the transceiver transitions to Doze or Hibernate mode

9.2.1 Configuring GPIO Direction

The GPIO are configured using GPIO_Dir Register 0B. Each I/O has a gpiox_oen output enable bit and a gpiox_ien input enable bit. Exiting reset, the default condition for these enable bits is that the gpiox_ien bits are set to 1 which enables the pins as inputs and gpiox_oen are cleared.

NOTE

If any bit is programmed to be an input and output simultaneously, the input condition overrides.

9.2.2 Setting GPIO Output Drive Strength

If any GPIO are programmed as outputs, their drive strength is programmable. GPIO1 through GPIO4 are programmed as a group for drive strength by writing to control field gpio1234_drv[1:0], GPIO_Dir Register 0B, and GPIO5 through GPIO7 are programmed as a group by writing to gpio567_drv[1:0], GPIO_Data_Out Register 0C. There are 4 levels of drive strength with field value 00 for lowest and value 11 for greatest.

9.2.3 Programming GPIO Output Value

GPIO_Data_Out Register 0C has a gpiox_o bit for each GPIO pin that establishes the corresponding output's state when that I/O is programmed as an output. Setting a gpiox_o to 1 sets the output high.

9.2.4 Reading GPIO Input State

GPIO_Data_In Register 28 has a `gpiox_i` bit for each GPIO pin. When a GPIO is programmed as an input, its state can be determined by reading the corresponding `gpiox_i` bit in the register.

9.2.5 GPIO1 and GPIO2 as Status Indicators

To support easier and quicker status indication for the MCU, GPIO1 and GPIO2 can be programmed for special alternative functionality. If the `gpio_alt_en` bit of Control_C Register 09 is set to 1 then:

1. GPIO1 becomes an “Out of Idle” indicator (active high) - GPIO1 will always reflect the status of the internal state machine. If the MC13192 is in a TX or RX or CCA/ED sequence, the GPIO1 will be high. Once the sequence ends, the GPIO1 returns to a low state and shows that the transceiver has returned to Idle. In Doze or Hibernate mode GPIO1 stays low.
2. GPIO2 becomes a “Valid CRC” or “Valid CCA Result” indicator (active high) -
 - a) For a RX sequence, the GPIO2 will show the CRC is valid once the RX operation is complete and GPIO1 goes to low to indicate a return to Idle condition. The transition of GPIO1 from high to low latches the CRC result on GPIO2 and that status will not change until the next transceiver sequence. GPIO2 will not be valid if an error condition such as a PLL out-of-lock condition occurs
 - b) For a CCA sequence, the GPIO2 will show if the CCA is valid once the CCA operation is complete and GPIO1 goes to low to indicate a return to Idle condition. The transition of GPIO1 from high to low latches the CCA result on GPIO2 and that status will not change until the next transceiver sequence. GPIO2 will not be valid if an error condition such as a PLL out-of-lock condition occurs

These two signals can be used by the MCU to monitor transceiver status during stream mode without interrogating the onboard status registers.

NOTE

GPIO1 and GPIO2 should also be programmed as outputs for this function.

9.3 Crystal Oscillator

The crystal oscillator for the MC13192 uses the following external pins:

1. XTAL1 - reference oscillator input.
2. XTAL2 - reference oscillator output. This pin should not be loaded to be used as a reference source or to measure frequency; instead use CLK0 to measure or supply 16 MHz.

The external crystal circuit is shown in [Figure 9-1](#).

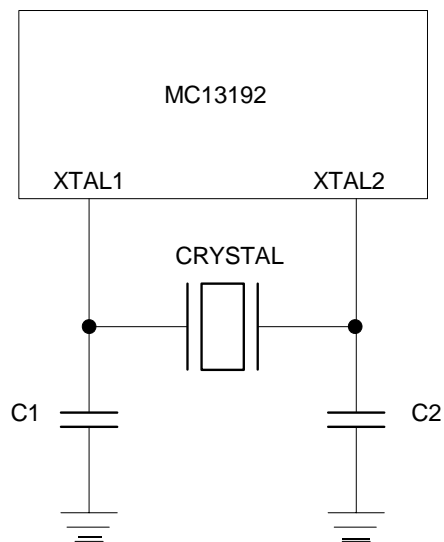

Figure 9-1. Crystal Oscillator Circuit

9.3.1 Crystal Requirements

The MC13192 requires that only a 16 MHz crystal with a <9 pF load capacitance can be used. The load capacitance limitation is required due to internal oscillator circuit and the ability to trim the oscillator as described in the next section. A tight frequency tolerance on the crystal may also be required due to the 802.15.4 Standard which demands that frequency tolerances be kept within +/- 40 ppm. This requirement is for the oscillator circuit, not just the crystal. This is covered in detail in the MC13192 Data Sheet, MC13192DS. Selected crystals are discussed in AN3251 *Reference Oscillator Crystal Requirements for the MC1319x, MC1320x, and MC1321x*

9.3.2 Crystal Trim Operation

The MC13192 uses the 16 MHz crystal oscillator with warp capability as the reference oscillator for the system. The warp capability is done by the MC13192 and is controlled by programming CLKO_Ctl Register 0A, Bits 15-8 (xtal_trim[7:0]). The trimming procedure varies the frequency by a few hertz per step, depending on the type of crystal. The high end of the frequency spectrum is set when xtal_trim[7:0] is set to zero. As xtal_trim[7:0] is increased, the frequency is decreased. Accuracy of this feature can be observed by varying xtal_trim[7:0] and using a spectrum analyzer or frequency counter to track the change in frequency of the crystal signal. The reference oscillator frequency can be measured at the CLKO contact by programming CLKO_Ctl Register 0A, Bits 2-0, to value 000. The crystal frequency should not be monitored at IC pins 26 or 27 (XTAL1 or XTAL2) because this will load the oscillator and alter the frequency.

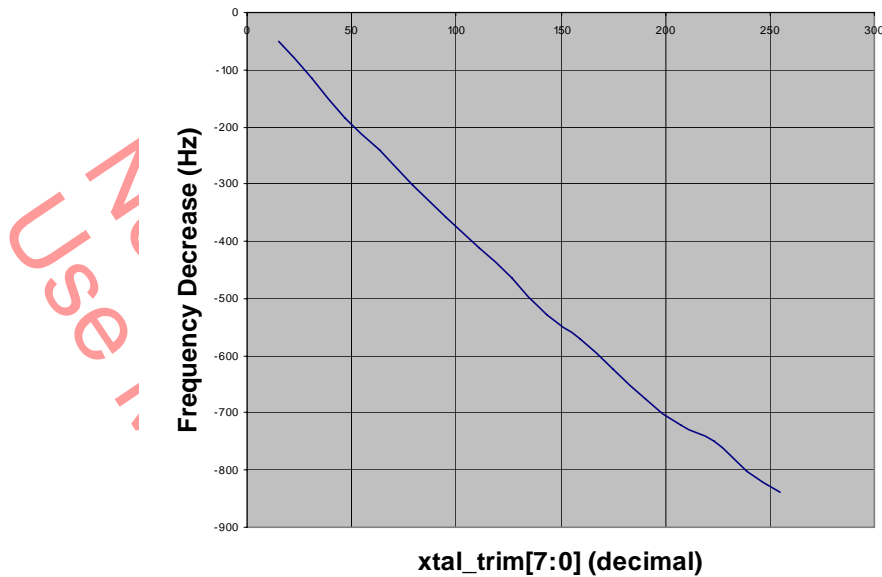

Figure 9-2. Crystal Frequency Variation vs. xtal_trim[7:0]

Figure 9-2 shows typical oscillator frequency decrease versus the value programmed in xtal_trim[7:0].

9.4 Output Clock Pin CLKO

The MC13192 can supply a clock output useful as a frequency source for a microcontroller, frequency test point, or reference for other uses. The clock output is available on signal CLKO and can be turned on or off as a power saving measure (default is CLKO active). CLKO is controlled by a number of control fields.

9.4.1 Enable CLKO (clko_en, Control_C Register 09, Bit 5)

Setting clko_en, Control_C Register 9, Bit 5, to 1 enables the CLKO signal. The default condition out of reset is that the clock out is enabled at the default frequency of 32.768+ kHz set by field clko_rate[2:0].

9.4.2 Setting CLKO frequency (clko_rate[2:0], CLKO_Ctl Register 0A, Bits 2-0)

The 3-bit field clko_rate[2:0], CLKO_Ctl Register 0A, Bits 2-0, selects the output frequency based on the programmed value. Frequencies from 16 MHz to 16 kHz are available. Default frequency is 32.768+ kHz with a field value of clko_rate[2:0] = 110. Table 4-13 lists the CLKO frequencies versus clko_rate[2:0] program value.

9.4.3 Enable CLKO During Doze Mode (clko_doze_en, Control_B Register 07, Bit 9)

Bit clko_doze_en, Control_B register 07, Bit 9, is used to control CLKO during Doze mode. If clko_doze_en is set to 1 before entering Doze mode, CLKO will continue to toggle while the MC13192 is

Miscellaneous Functions

in Doze mode. The CLKO frequency must be set for 1 MHz or lower. Default out of reset is `clko_doze_en = 0` as a power-saving measure.

If `clko_doze_en = 0` and CLKO was enabled, CLKO will stop toggling 128 reference clock (16 MHz) cycles after the `doze_en` bit is programmed to 1. CLKO will automatically re-start after exiting Doze with the exception of the two lowest frequencies.

NOTE

The two lowest frequencies of 16.393+ kHz and 32.786+ kHz will not restart directly when exiting Doze mode. To restart CLKO for these frequencies, the `clko_en`, Control_C Register 09, Bit 5, must be cleared and set again.

9.4.4 Setting CLKO Output Drive Strength (`clko_drv[1:0]`, GPIO_Data_Out Register 0C, Bits 11-10)

The CLKO output drive strength can be programmed to 4 different levels by writing to `clko_drv[1:0]`, GPIO_Data_Out Register 0C, Bits 11-10. The default value is the lowest drive value of 00. Note that for higher frequencies such as 16 MHz, the CLKO must be programmed for highest drive. Table 9-1 shows output drive strength for maximum frequency and maximum load capacitance.

Table 9-1. CLKO Drive Strength Versus `clko_drv[1:0]` Value

Drive Strength (<code>clko_drv[1:0]</code>)	Max Freq (MHz)	Max C_{load} (pF)
00	1	20
01	8	20
10	16	20
11	16	$20 < C_{load}$

9.5 Input Pin \overline{ATTN}

The attention or \overline{ATTN} signal is used to exit either Doze mode or Hibernate mode.

NOTE

Doze mode may also be exited via a `tmr_cmp2` compare event. A transition event from high to low (assertion) on \overline{ATTN} is will always exit either mode.

The \overline{ATTN} assertion low event can also generate an interrupt. The interrupt status bit is `atn_irq`, IRQ_Status Register 24, Bit 10, and the interrupt mask bit is `atn_mask`, IRQ_Mask Register 05, Bit 15.