

SOT1331-1

plastic thermal enhanced thin shrink small outline package;
38 leads; body with 4.4 mm; lead pitch 0.5 mm; exposed die
pad

8 February 2016

Package information

1. Package summary

Terminal position code	D (double)
Package type descriptive code	HTSSOP38
Package type industry code	HTSSOP38
Package style descriptive code	HTSSOP (thermal enhanced thin shrink small outline package)
Package style suffix code	NA (not applicable)
Package body material type	P (plastic)
Mounting method type	S (surface mount)
Issue date	21-9-2012

Table 1. Package summary

Symbol	Parameter	Min	Typ	Nom	Max	Unit
D	package length	9.6	-	9.7	9.8	mm
E	package width	4.3	-	4.4	4.5	mm
A	seated height	[tbd]	-	[tbd]	1.1	mm
A ₂	package height	0.85	-	0.9	0.95	mm
e	nominal pitch	-	-	0.5	-	mm
n ₂	actual quantity of termination	-	-	38	-	



plastic thermal enhanced thin shrink small outline package; 38 leads; body with 4.4 mm; lead pitch 0.5 mm; exposed die pad

2. Package outline

HTSSOP38: plastic thermal enhanced thin shrink small outline package; 38 leads; body with 4.4 mm; lead pitch 0.5 mm; exposed die pad

SOT1331-1

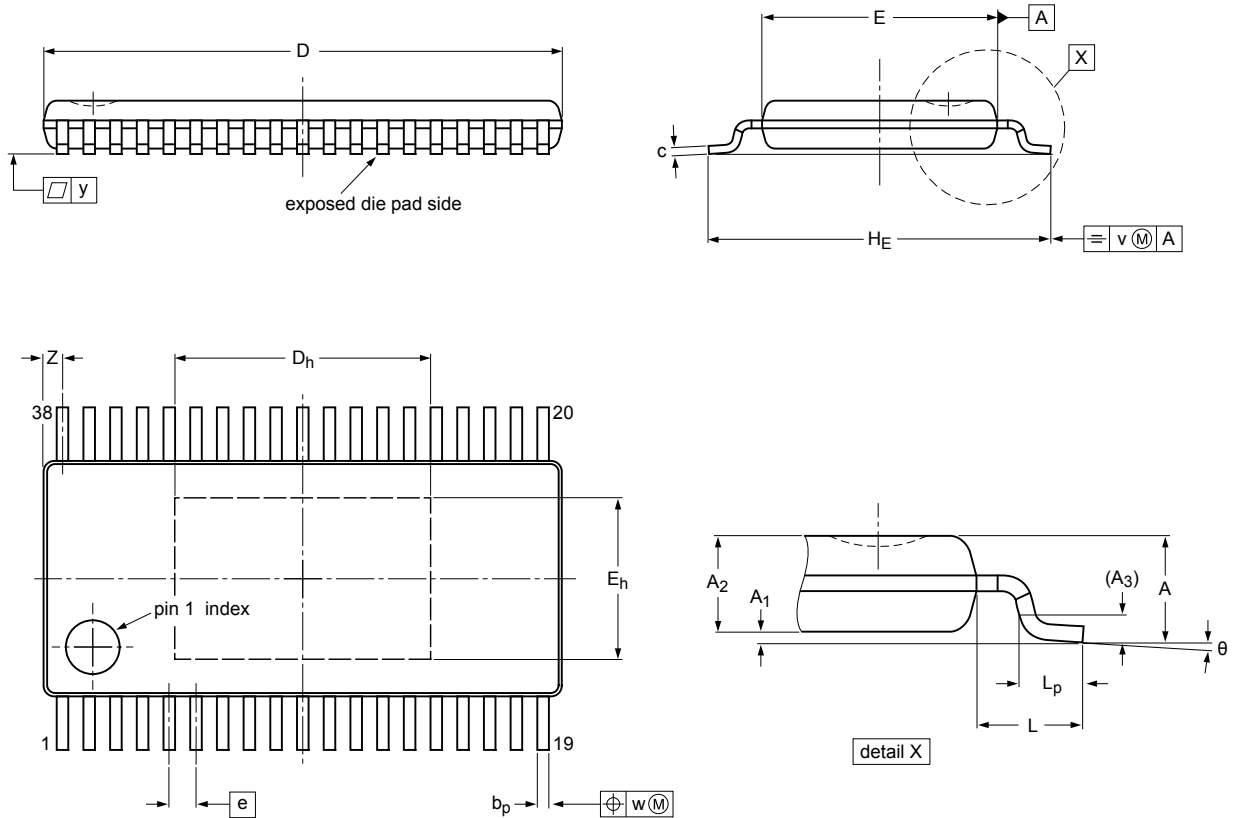

Dimensions (mm are the original dimensions)

Unit ⁽¹⁾	A	A ₁	A ₂	A ₃	b _p	c	D ⁽¹⁾	D _h	E ⁽¹⁾	E _h	e	H _e	L	L _p	v	w	y	Z	θ
max	1.1	0.15	0.95		0.27	0.20	9.8	4.9	4.5	3.1								0.49	8°
nom		0.10	0.90	0.25	0.21	0.15	9.7	4.8	4.4	3.0	0.5	6.4	1.0	0.6	0.2	0.08	0.08	0.35	4°
min		0.05	0.85		0.17	0.09	9.6	4.7	4.3	2.9				0.5				0.21	0°

Note

1. Plastic or metal protrusions of 0.15 mm maximum per side are not included.
2. Plastic interlead protrusions of 0.25 mm maximum per side are not included.

sot1331-1_po

Outline version	References			European projection	Issue date
	IEC	JEDEC	JEITA		
SOT1331-1					-12-07-30- 12-08-20

Fig. 1. Package outline HTSSOP38 (SOT1331-1)

plastic thermal enhanced thin shrink small outline package; 38 leads; body with 4.4 mm; lead pitch 0.5 mm; exposed die pad

3. Soldering

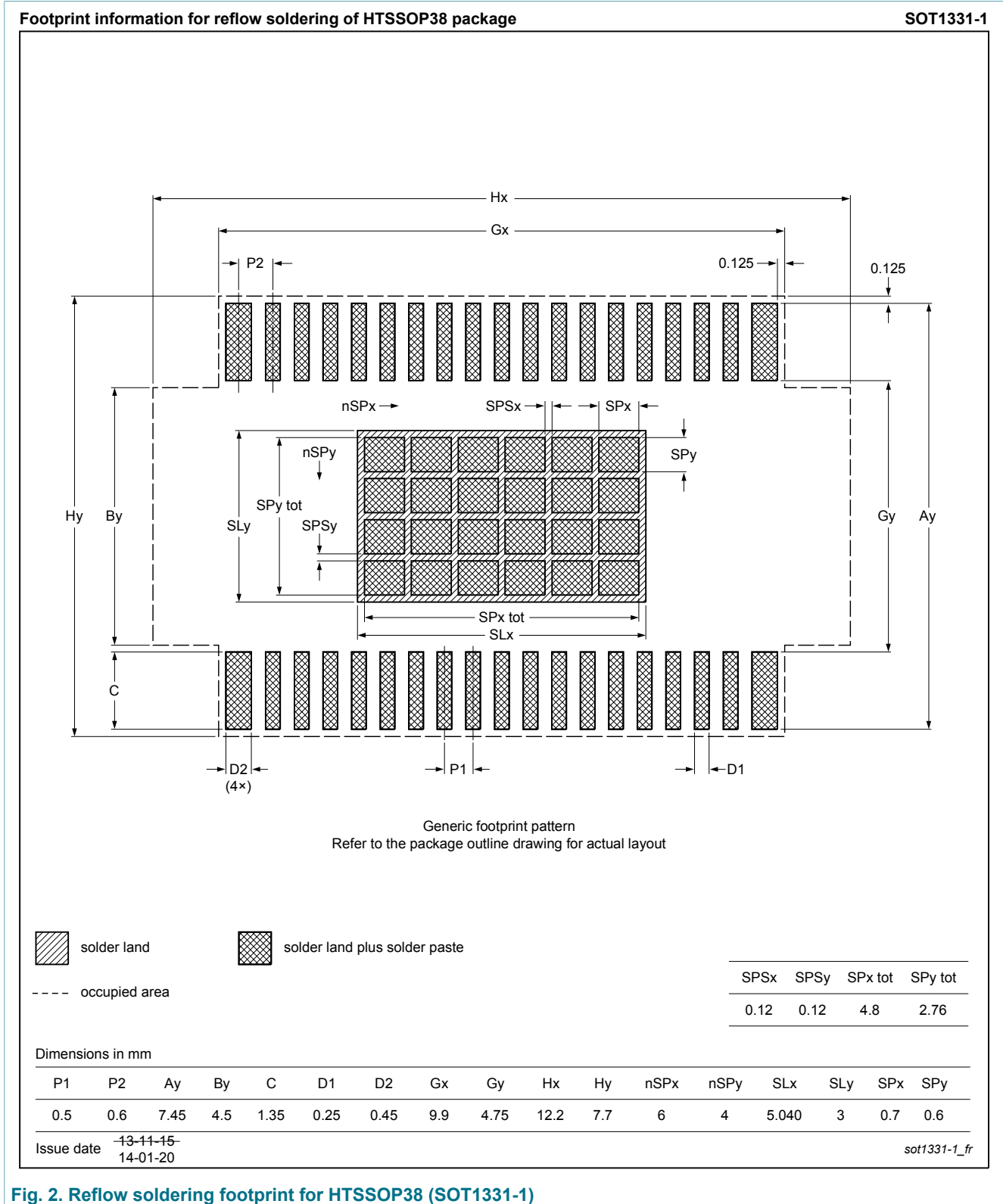

Fig. 2. Reflow soldering footprint for HTSSOP38 (SOT1331-1)

plastic thermal enhanced thin shrink small
outline package; 38 leads; body with 4.4 mm;
lead pitch 0.5 mm; exposed die pad

4. Legal information

Disclaimers

Limited warranty and liability — Information in this document is believed to be accurate and reliable. However, NXP Semiconductors does not give any representations or warranties, expressed or implied, as to the accuracy or completeness of such information and shall have no liability for the consequences of use of such information. NXP Semiconductors takes no responsibility for the content in this document if provided by an information source outside of NXP Semiconductors.

In no event shall NXP Semiconductors be liable for any indirect, incidental, punitive, special or consequential damages (including - without limitation - lost profits, lost savings, business interruption, costs related to the removal or replacement of any products or rework charges) whether or not such damages are based on tort (including negligence), warranty, breach of contract or any other legal theory.

Notwithstanding any damages that customer might incur for any reason whatsoever, NXP Semiconductors' aggregate and cumulative liability towards customer for the products described herein shall be limited in accordance with the *Terms and conditions of commercial sale* of NXP Semiconductors.

Right to make changes — NXP Semiconductors reserves the right to make changes to information published in this document, including without limitation specifications and product descriptions, at any time and without notice. This document supersedes and replaces all information supplied prior to the publication hereof.

plastic thermal enhanced thin shrink small
outline package; 38 leads; body with 4.4 mm;
lead pitch 0.5 mm; exposed die pad

5. Contents

1. Package summary.....	1
2. Package outline.....	2
3. Soldering.....	3
4. Legal information.....	4

© NXP Semiconductors N.V. 2016. All rights reserved

For more information, please visit: <http://www.nxp.com>

For sales office addresses, please send an email to: salesaddresses@nxp.com

Date of release: 8 February 2016
