



Transport Ticketing

Last Updated: Oct 13, 2023

NXP offers fast and secure solutions for access to, and payment in, public transport. These range from smart cards and ticket ICs to mobile and wearable applications.

Our secure RAIN RFID ICs support hands-free access in public transport, which makes it easier to get around without having to tap a card or ticket to a reader.

Transport barrier systems can validate tickets and also take contactless payment from credit cards and mobile phones. These systems maintain a database of all transactions including a local copy kept in the machine and a copy uploaded to a central database.

Transport Ticketing Block Diagram

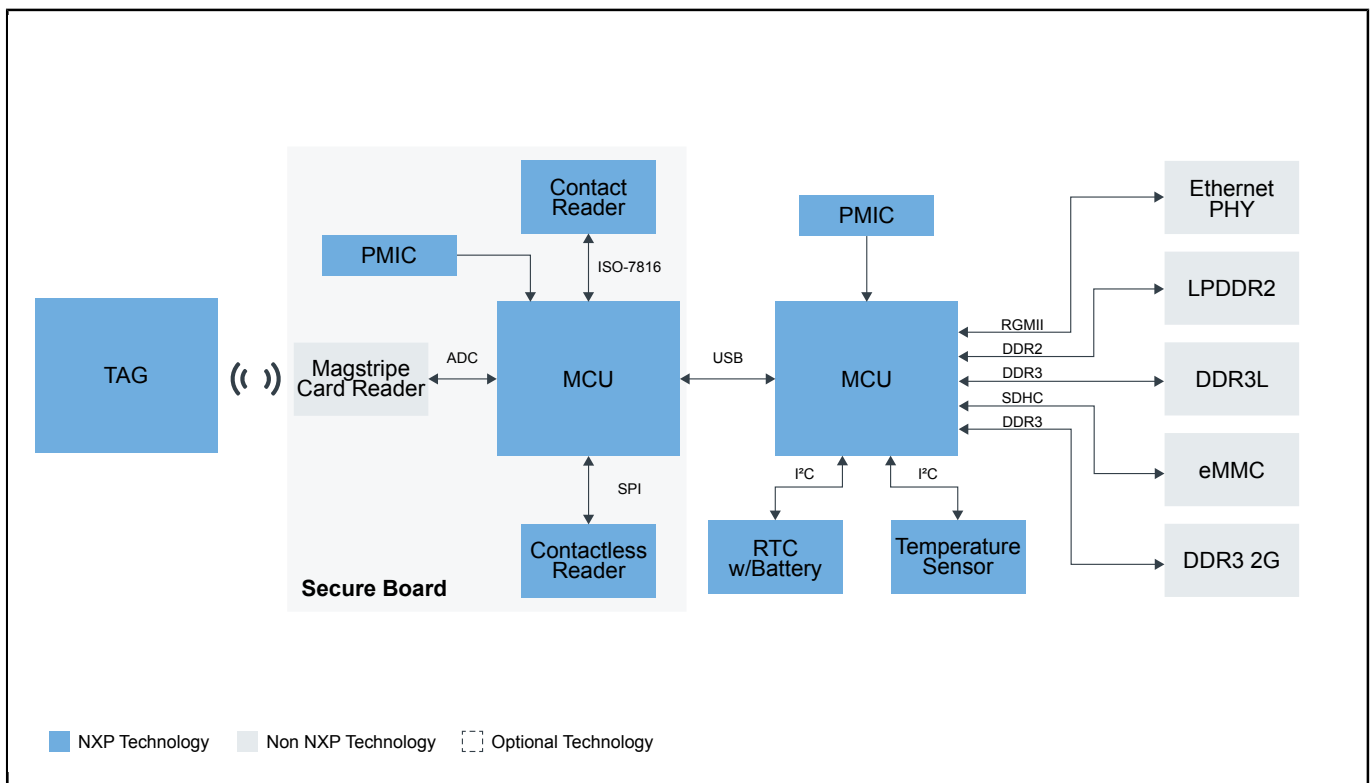

Recommended Products for Transport Ticketing	
MCU	<ul style="list-style-type: none"> • K81_150: Kinetis K81-150 MHz HW Cryptographic Co-Processor, Anti-Tamper and QuadSPI Microcontrollers (MCUs) Based on Arm® Cortex®-M4 Core • i.MX6ULL: i.MX 6ULL Single-Core Processor with Arm® Cortex®-A7 Core
Readers	<ul style="list-style-type: none"> • TDA8035HN: High-Integrated and Low-Power Smart Card Interface • PN5180: Full NFC Forum-Compliant Frontend IC
Peripherals	<ul style="list-style-type: none"> • PCT2075: I²C-Bus Fm+, 1 Degree C Accuracy, Digital Temperature Sensor and Thermal Watchdog • PCF85263A: Tiny Real-Time Clock/Calendar with Alarm Function, Battery Switch-Over, Time Stamp Input and I²C-Bus
TAG	<ul style="list-style-type: none"> • MIFARE DESFire: MIFARE® DESFire® • MIFARE Plus: MIFARE Plus® • SL3S5002N0FUD: UCODE® DNA: UHF Tag IC for Secure Authentication
Readers	<ul style="list-style-type: none"> • TDA8035HN: High-Integrated and Low-Power Smart Card Interface • PN5180: Full NFC Forum-Compliant Frontend IC
Peripherals	<ul style="list-style-type: none"> • P3T1035xUK: I3C, I²C-Bus, ±0.5 °C Accuracy, Digital Temperature Sensor • P3T2030xUK: I3C, I²C-Bus, 2.0 °C Accuracy, Digital Temperature Sensor • PCT2075: I²C-Bus Fm+, 1 Degree C Accuracy, Digital Temperature Sensor and Thermal Watchdog • PCF85263A: Tiny Real-Time Clock/Calendar with Alarm Function, Battery Switch-Over, Time Stamp Input and I²C-Bus
PMIC	<ul style="list-style-type: none"> • PCA9460: 13-Channel Power Management Integrated Circuit (PMIC) for Ultra Low Power Application

View our complete solution for [Transport Ticketing](#).

Note: The information on this document is subject to change without notice.

www.nxp.com

NXP and the NXP logo are trademarks of NXP B.V. All other product or service names are the property of their respective owners. The related technology may be protected by any or all of patents, copyrights, designs and trade secrets. All rights reserved. © 2024 NXP B.V.