



# TJA1100, IEEE 100BASE-T1 Compliant Automotive Ethernet PHY Transceiver

## TJA1100

### **Not Recommended for New Designs**

This page contains information on a product that is not recommended for new designs.

Last Updated: Mar 21, 2024

The TJA1100 is IEEE 100BASE-T1 compliant. The single port Ethernet PHY Transceiver is designed and fully qualified for automotive applications. It supports 100 Mbit/s transmit and receive capability up to at least 15 m of unshielded twisted pair (UTP) cables. The TJA1100 enables lowest system cost and fulfills the demanding area and heat constraints of next-generation electronic control units (ECU) and sensors for Advanced Driver Assistance System (ADAS). Qualified in compliance with AEC-Q100 Grade 1, the TJA1100 is natively designed for the smallest package footprint, minimal external component overhead, and low power.

# TJA1100 Block Diagram

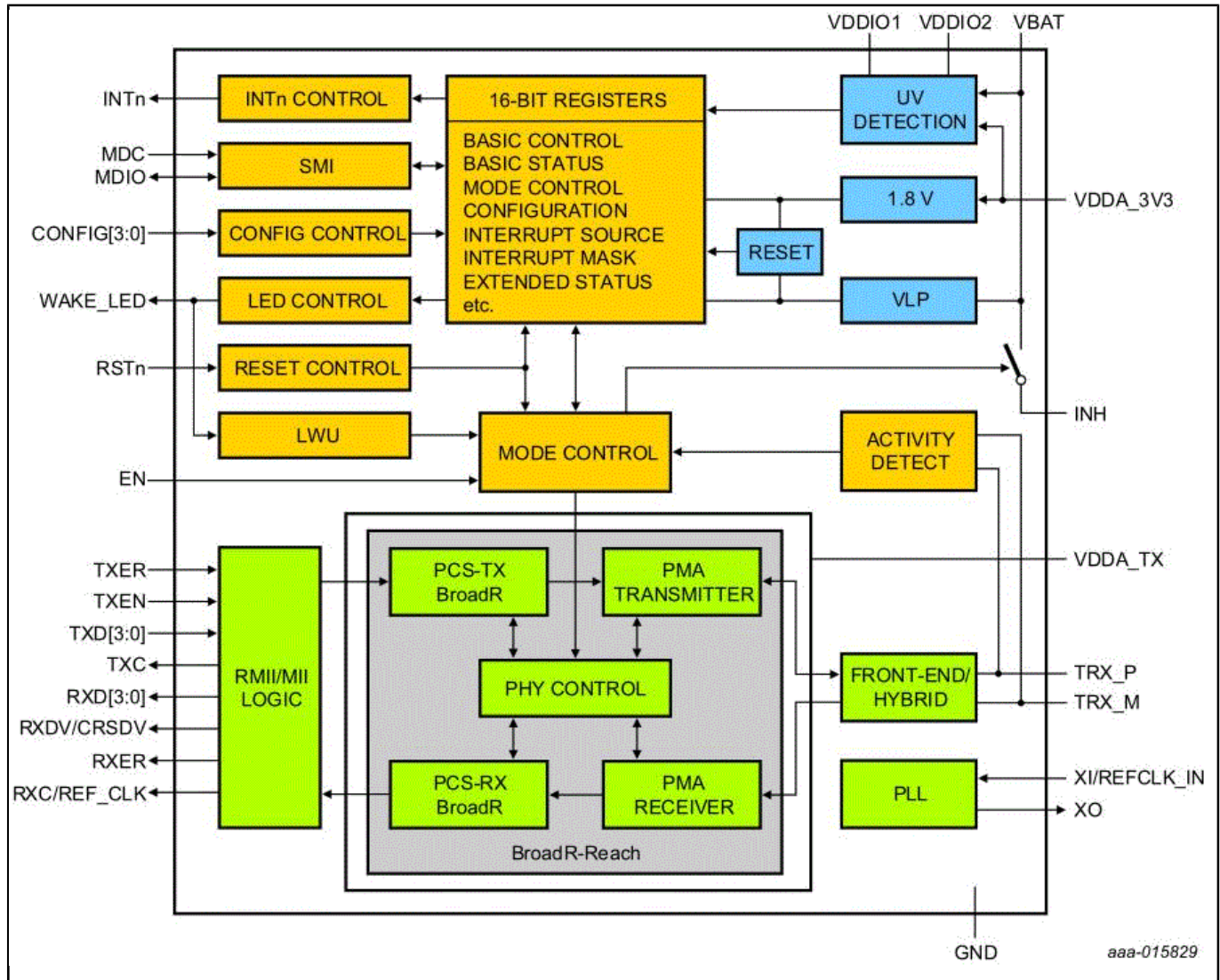

View additional information for [TJA1100, IEEE 100BASE-T1 Compliant Automotive Ethernet PHY Transceiver](#).

Note: The information on this document is subject to change without notice.

[www.nxp.com](http://www.nxp.com)

NXP and the NXP logo are trademarks of NXP B.V. All other product or service names are the property of their respective owners. The related technology may be protected by any or all of patents, copyrights, designs and trade secrets. All rights reserved. © 2024 NXP B.V.