



Low-Cost One-Chip 5 V Qi Wireless Transmitter

NXQ1TXL5

Not Recommended for New Designs

This product is Not Recommended for New Designs. Please visit our [Wireless Power Portfolio](#) for more options.

Last Updated: May 24, 2022

The NXQ1TXL5 is a low cost drop-in replacement for the NXQ1TXH5 one-chip low power Qi charger transmitter device. The NXQ1TXL5 is a fully integrated one-chip controller and driver IC enabling the design of a 5 V Qi-compliant low-power wireless charger. It includes a 5 V full-bridge power stage, as defined in the Wireless Power Consortium (WPC) low power Qi configurations A5, A11, A12 and A16. The device is optimized for minimum external component count, enabling a very low cost application and a simple PCB design.

The NXQ1TXL5 has all benefits and the same high integration level of the NXQ1TXH5 device, but it comes with less configuration options and does not support Foreign Object Detection (FOD). The NXQ1TXL5 application becomes simple, enabling a true plug & play experience for the design of a low power Qi-compliant wireless charger for applications that do not require to meet full Qi certification requirements. The fixed configuration enables even further reducing the component count and allowing an even simpler PCB layout, even though it can also be used to drop into an existing NXQ1TXH5 PCB layout, omitting the external configuration resistors.

The NXQ1TXL5 uses dedicated analog ping circuitry to detect devices, according to the Qi standard, achieving a very low standby power consumption of 10 mW. The NXQ1TXL5 takes care of a reliable ASK communication and controls the wireless power transfer from the transmitter to the receiver. LED outputs are available for the user interface and the LED blinking modes is fixed.

The NXQ1TXL5 comes in a size optimized low cost 5 mm × 5 mm, 32-pin HVQFN package.

NXQ1TXL5 Block Diagram Block Diagram

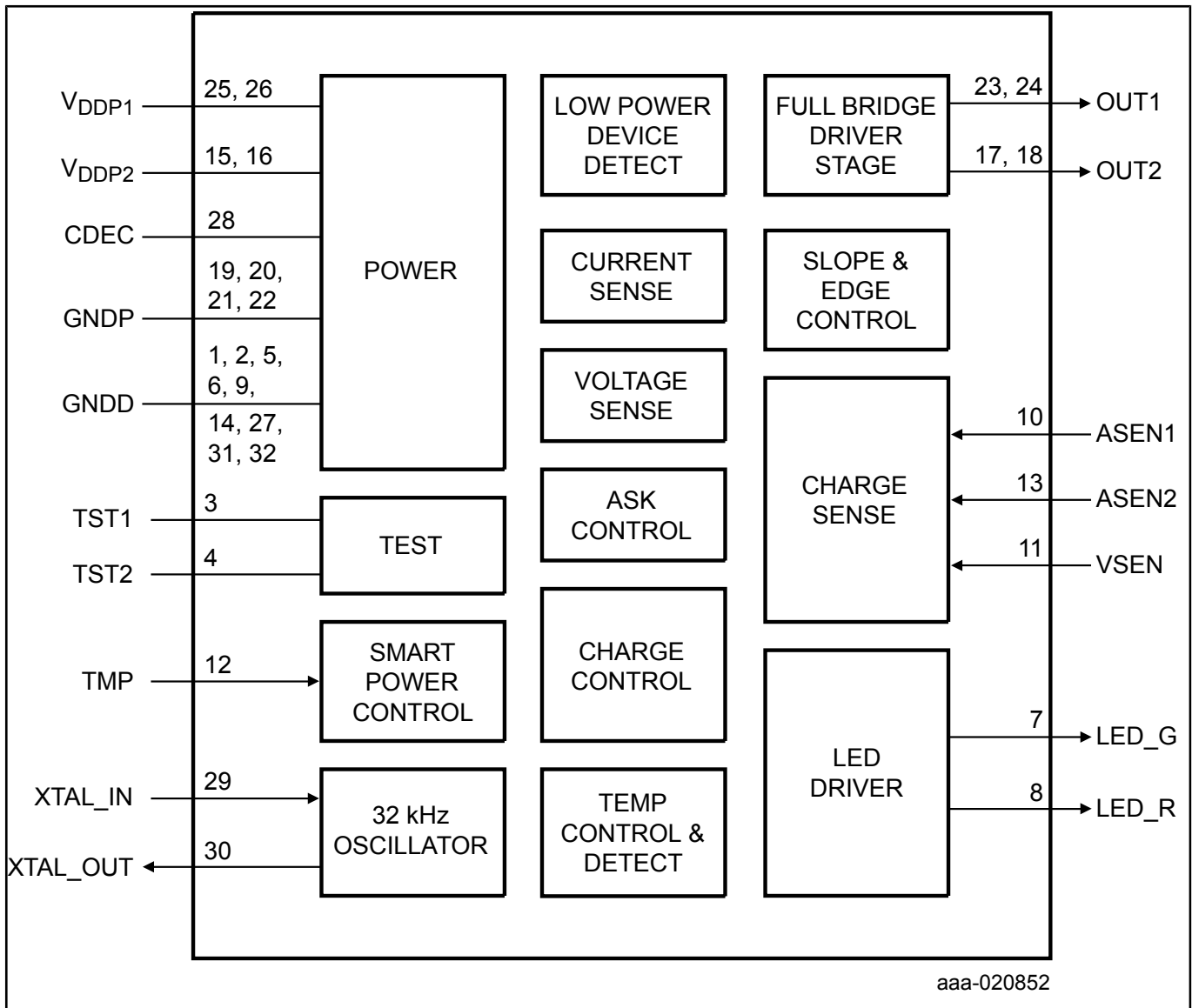

View additional information for [Low-Cost One-Chip 5 V Qi Wireless Transmitter](#).

Note: The information on this document is subject to change without notice.

www.nxp.com

NXP and the NXP logo are trademarks of NXP B.V. All other product or service names are the property of their respective owners. The related technology may be protected by any or all of patents, copyrights, designs and trade secrets. All rights reserved. © 2024 NXP B.V.