



PowerQUICC® Processor with CPM (2 SCC, 1 SMC), 10/100 Ethernet

MPC853T

Last Updated: Apr 9, 2022

The MPC853T is an "ethernet-only" member of the MPC866 Family. Like the MPC866, the MPC853T is a 0.18 micron version of the PowerQUICC® Family and can operate up to a maximum of 100 MHz on the MPC8xx Core with a maximum of 66 MHz external bus. The MPC853T has a 1.8 V core and has a 3.3 V I/O operation with 5 V TTL compatibility. The MPC853T Integrated Communications Controller is a versatile one-chip integrated microprocessor and peripheral combination that can be used in a variety of controller applications. The MPC853T is ideal for voice-enabled systems (TDM-based) and ethernet to ethernet applications such as line cards.

The MPC853T is a Power Architecture-based derivative of NXP® Semiconductors's Quad Integrated Communications Controller (PowerQUICC).. The CPU on the MPC853T is the MPC8xx core, a 32-bit microprocessor built on Power Architecture technology, incorporating memory management units (MMUs) and instruction and data caches.

MPC853T Block Diagram Block Diagram

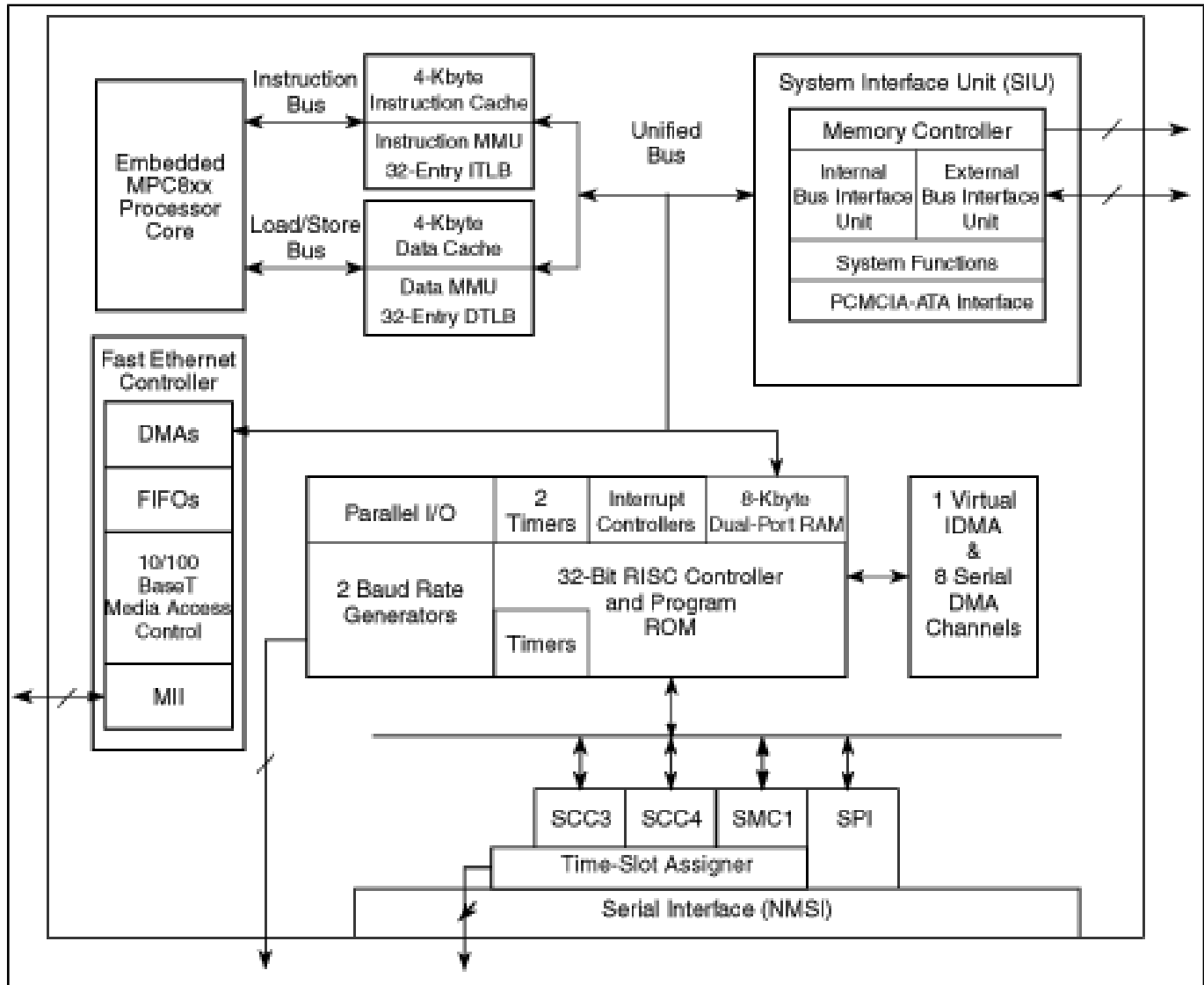

View additional information for [PowerQUICC® Processor with CPM \(2 SCC, 1 SMC\), 10/100 Ethernet.](#)

Note: The information on this document is subject to change without notice.

www.nxp.com

NXP and the NXP logo are trademarks of NXP B.V. All other product or service names are the property of their respective owners. The related technology may be protected by any or all of patents, copyrights, designs and trade secrets. All rights reserved. © 2024 NXP B.V.