



System Basis Chip with High Speed CAN

MC33989

Last Updated: Jan 19, 2024

The NXP® MC33989 is a monolithic integrated circuit that combines many functions frequently used in MCU-based systems, making it an economical solution for providing power, high speed communication, and control.

- Fully protected fixed 5.0 V low drop regulator output with current limit, over temperature pre-warning, and reset provides power for CAN and the MCU
- Provides drive and sense inputs to implement a second 5.0 V regulator using an external series pass PNP that is resistor ratio adjustable to meet peripheral needs
- An internally power supply voltage output with four wake-up inputs, programmable window watch-dog, interrupt, reset, high speed CAN transceiver and SPI input control

MC33989 BD Block Diagram

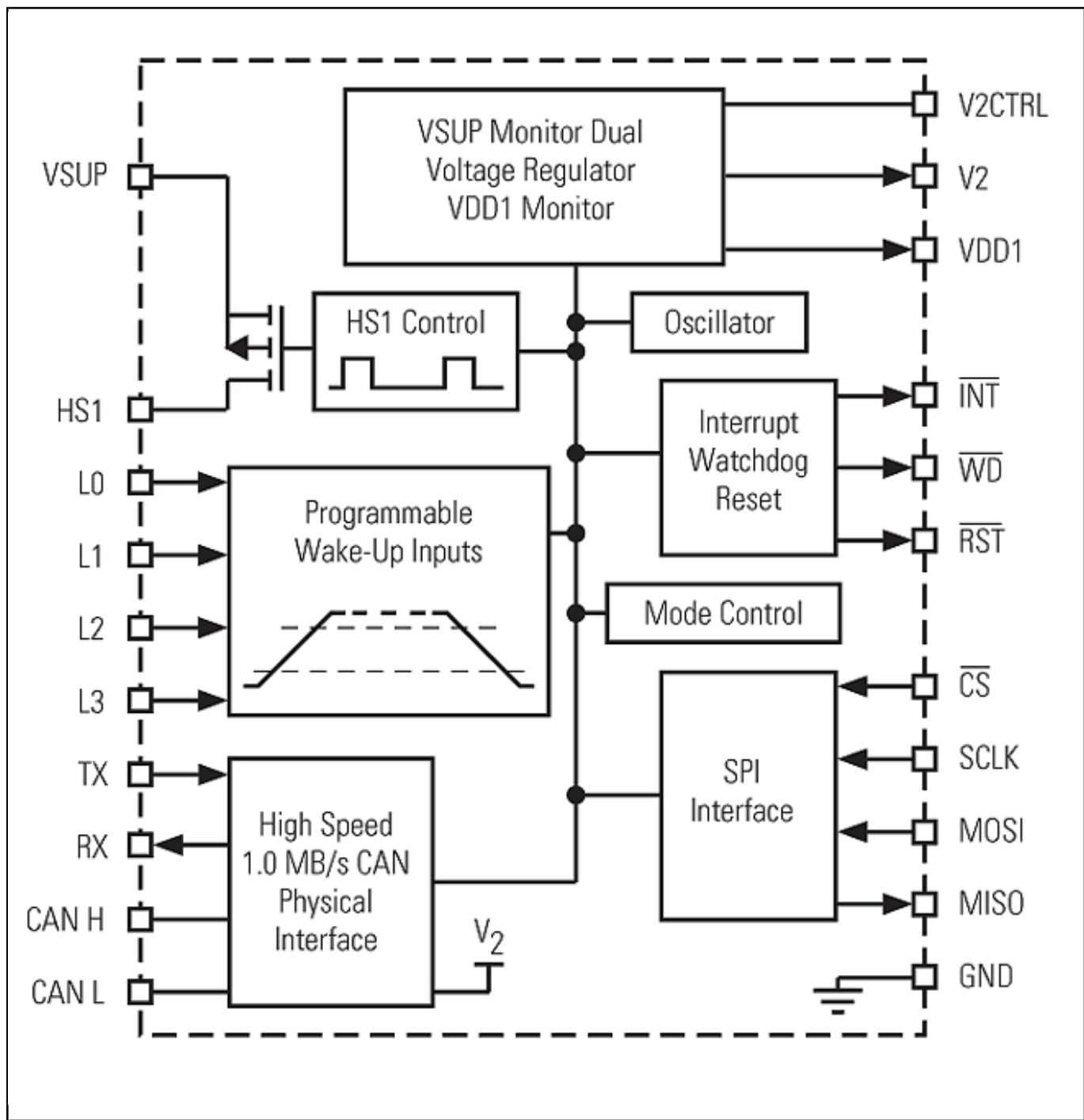

View additional information for [System Basis Chip with High Speed CAN](#).

Note: The information on this document is subject to change without notice.

www.nxp.com

NXP and the NXP logo are trademarks of NXP B.V. All other product or service names are the property of their respective owners. The related technology may be protected by any or all of patents, copyrights, designs and trade secrets. All rights reserved. © 2024 NXP B.V.