



# H-Bridge, Brushed DC Motor Driver, 5–28 V, 5 A, 11 kHz

## MC33931

Last Updated: Jul 20, 2023

The NXP® MC33931 is a monolithic H-Bridge power IC in a robust thermally enhanced package, designed primarily for automotive electronic throttle control, but is applicable to any low-voltage DC servo motor control application within the current and voltage limits stated in this specification.

- The MC33931 H-bridge is able to control inductive loads with currents up to 5.0 A peak
- RMS current capability is subject to the degree of heatsinking provided to the device package. Internal peak-current limiting (regulation) is activated at load currents above 6.5 A  $\pm 1.5$  A
- Output loads can be pulse-width modulated at frequencies up to 11 kHz
- [Processor Expert® component for medium voltage H-Bridge](#) products enables rapid embedded application development.

## MC33931 Simplified Application Drawing Block Diagram

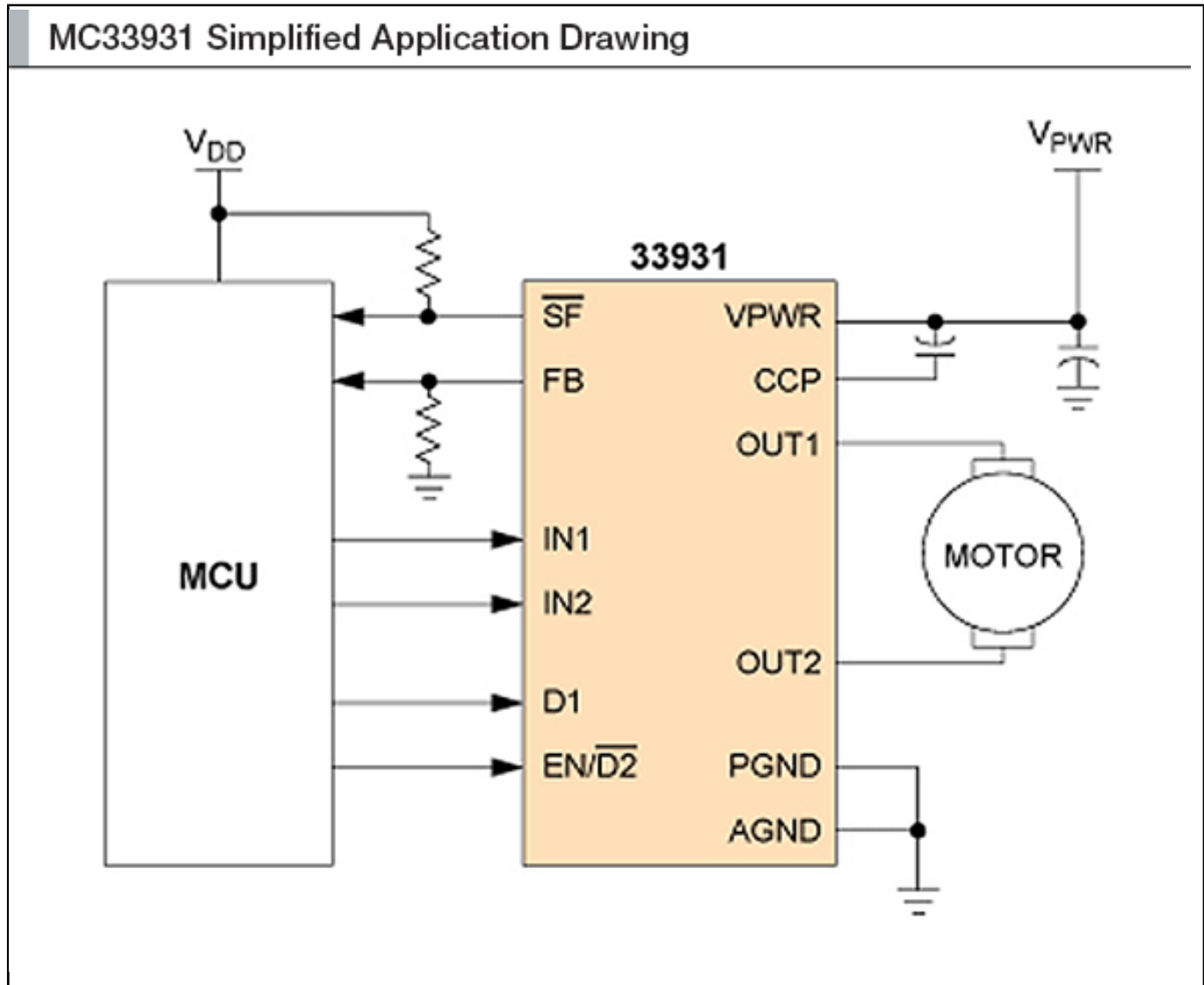

View additional information for [H-Bridge, Brushed DC Motor Driver, 5-28 V, 5 A, 11 kHz](#).

Note: The information on this document is subject to change without notice.

[www.nxp.com](http://www.nxp.com)

NXP and the NXP logo are trademarks of NXP B.V. All other product or service names are the property of their respective owners. The related technology may be protected by any or all of patents, copyrights, designs and trade secrets. All rights reserved. © 2024 NXP B.V.