



Multifunctional Ignition and Injector Driver

MC33812

Last Updated: Jul 20, 2023

The NXP® MC33812 is an engine control analog power IC intended for motorcycle and other single/dual cylinder small engine control applications.

- Consists of three integrated low side drivers, one pre-driver, a +5.0 V, voltage pre-regulator, an MCU watchdog circuit, an ISO 9141 K-Line interface, and a parallel interface for MCU communication
- The three low side drivers are provided for driving a fuel injector, a lamp or LED, and a relay or other load
- The pre-driver is intended to drive either an Insulated Gate Bipolar Transistor (IGBT) or a bipolar Darlington transistor to control an ignition coil

NXP MC33812 Low Side Switch Block Diagram Block Diagram

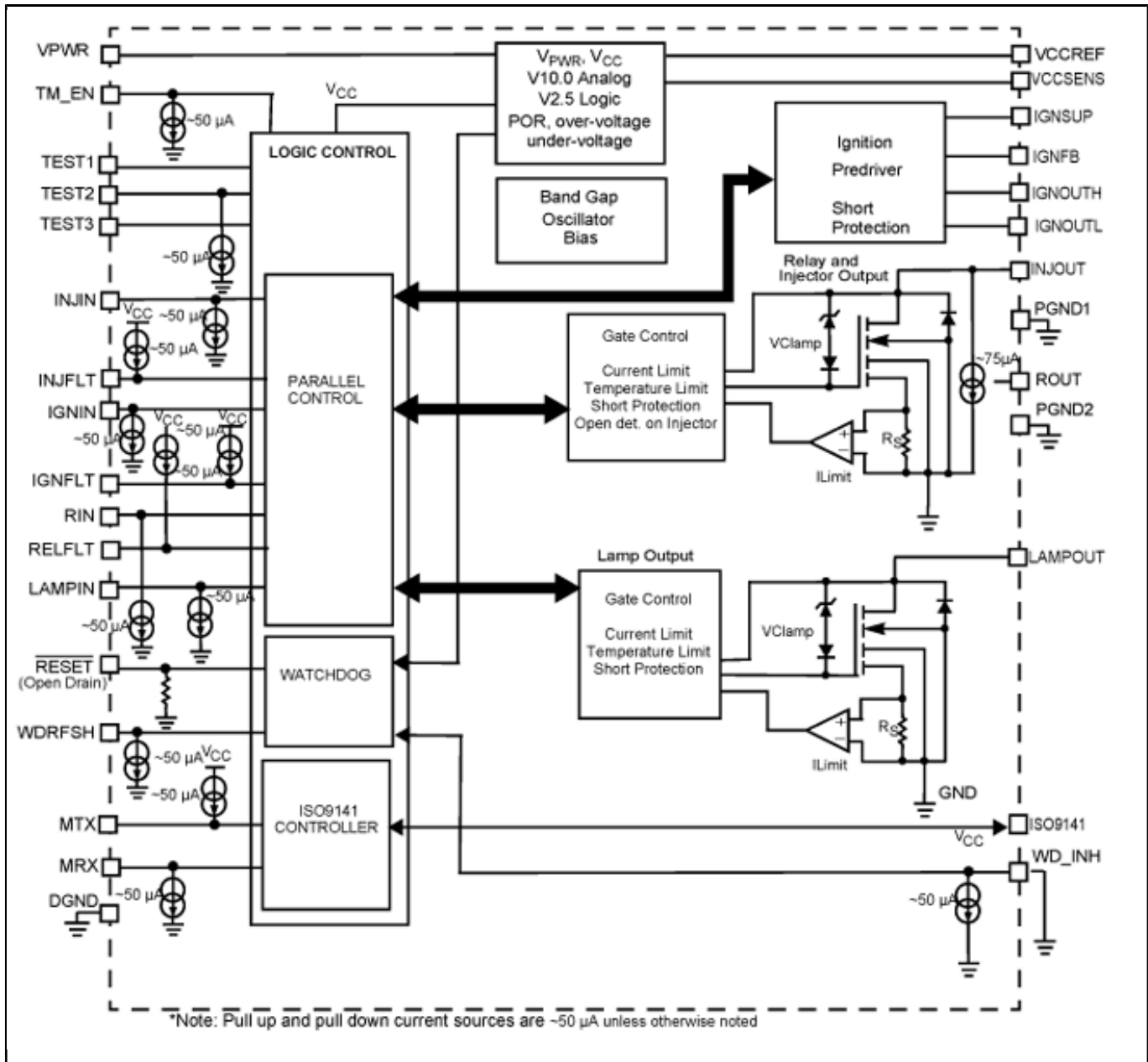

View additional information for [Multifunctional Ignition and Injector Driver](#).

Note: The information on this document is subject to change without notice.

www.nxp.com

NXP and the NXP logo are trademarks of NXP B.V. All other product or service names are the property of their respective owners. The related technology may be protected by any or all of patents, copyrights, designs and trade secrets. All rights reserved. © 2024 NXP B.V.