



# KEA128-3-Phase Sensorless BLDC Reference Design

## KEA128BLDCRD

Last Updated: Dec 13, 2023

This motor control reference design is based on a KEA128 32-bit Arm® Cortex®-M0+ automotive MCU. It is an example of a 3-phase sensorless brushless DC (BLDC) motor control solution using a six-step commutation process, including closed-loop speed control and dynamic motor current limitation.

# BLDC Block Diagram

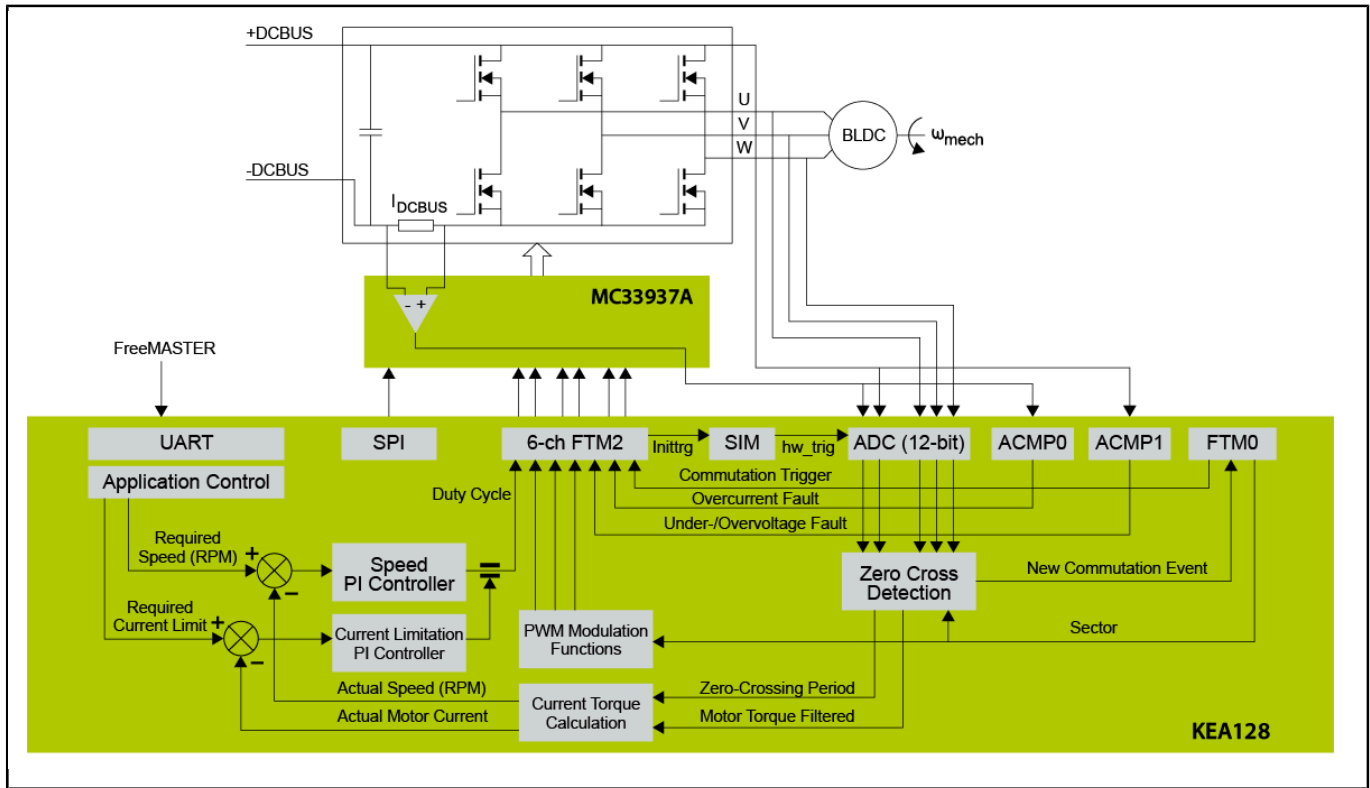

View additional information for [KEA128-3-Phase Sensorless BLDC Reference Design](#).

**Note:** The information on this document is subject to change without notice.

[www.nxp.com](http://www.nxp.com)

NXP and the NXP logo are trademarks of NXP B.V. All other product or service names are the property of their respective owners. The related technology may be protected by any or all of patents, copyrights, designs and trade secrets. All rights reserved. © 2024 NXP B.V.