



# Secure and Ultra-Low-Power MCU for Matter Over Thread™ and Bluetooth® LE 5.3

## K32W148

Last Updated: Apr 11, 2024

The K32W148 wireless MCU simplifies development of IoT devices with modular security and connectivity subsystems, allowing developers to focus on their innovation. With its integrated RF subsystem and a total memory footprint between the application core and the networking subsystem of 1.25 MB Flash and 216 KB RAM, the K32W148 enables seamless integration of Matter, Thread, Zigbee and Bluetooth Low Energy.

The K32W148 Arm® Cortex®-M33 main core, with 1 MB on-board flash and 128 KB SRAM, has enough room and flexibility for complex applications and over-the-air (OTA) upgrade capability without external memory. It also includes a rich set of MCU digital and analog peripherals and multiple serial communication interfaces for embedded connected applications.

Supporting the application core are a dedicated radio subsystem and an isolated EdgeLock® secure enclave. The radio subsystem, with its 256 kB Flash and 88 kB SRAM, offloads low-level radio operations from the application core, freeing resources for the main application, providing robust wireless performance and optimizing system level current draw. It also supports hardware accelerated Dual-PAN which enables bridging use cases for Thread and Zigbee with faster and more reliable time-slicing.

The EdgeLock secure enclave enables advanced security features such as key generation and storage, secure lifecycle management, secure boot and cryptographic acceleration in a protected execution environment. The K32W148 is also supported by NXP's EdgeLock® 2GO service which can install keys and certificates securely into the end devices and maintain the credentials throughout their life cycle. This service is authorized by the Connectivity Standards Alliance to serve as a Product Attestation Authority for Matter device attestation certificates streamlining the process for device manufacturers to develop and deploy a full Matter device.

## K32W148 Architecture Block Diagram

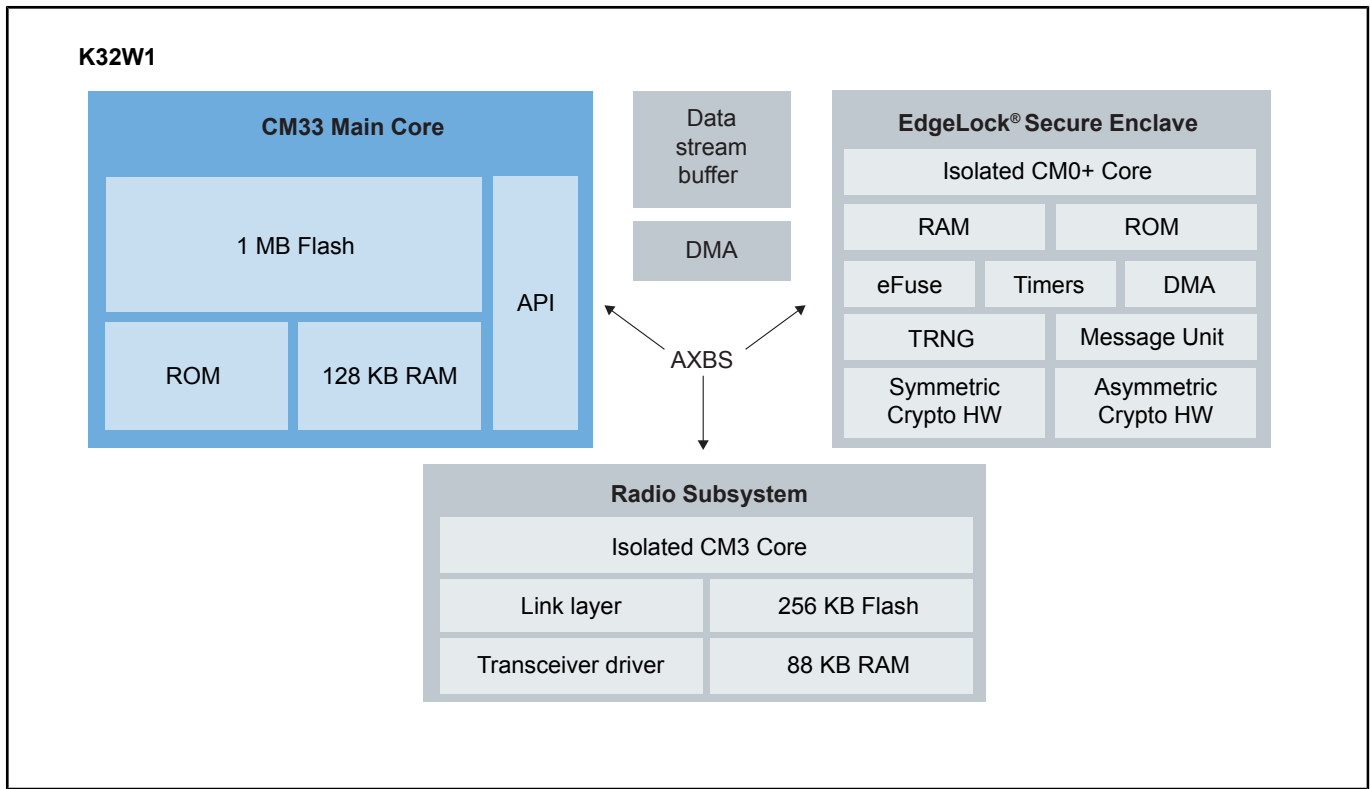

## K32W148 Device Features Block Diagram

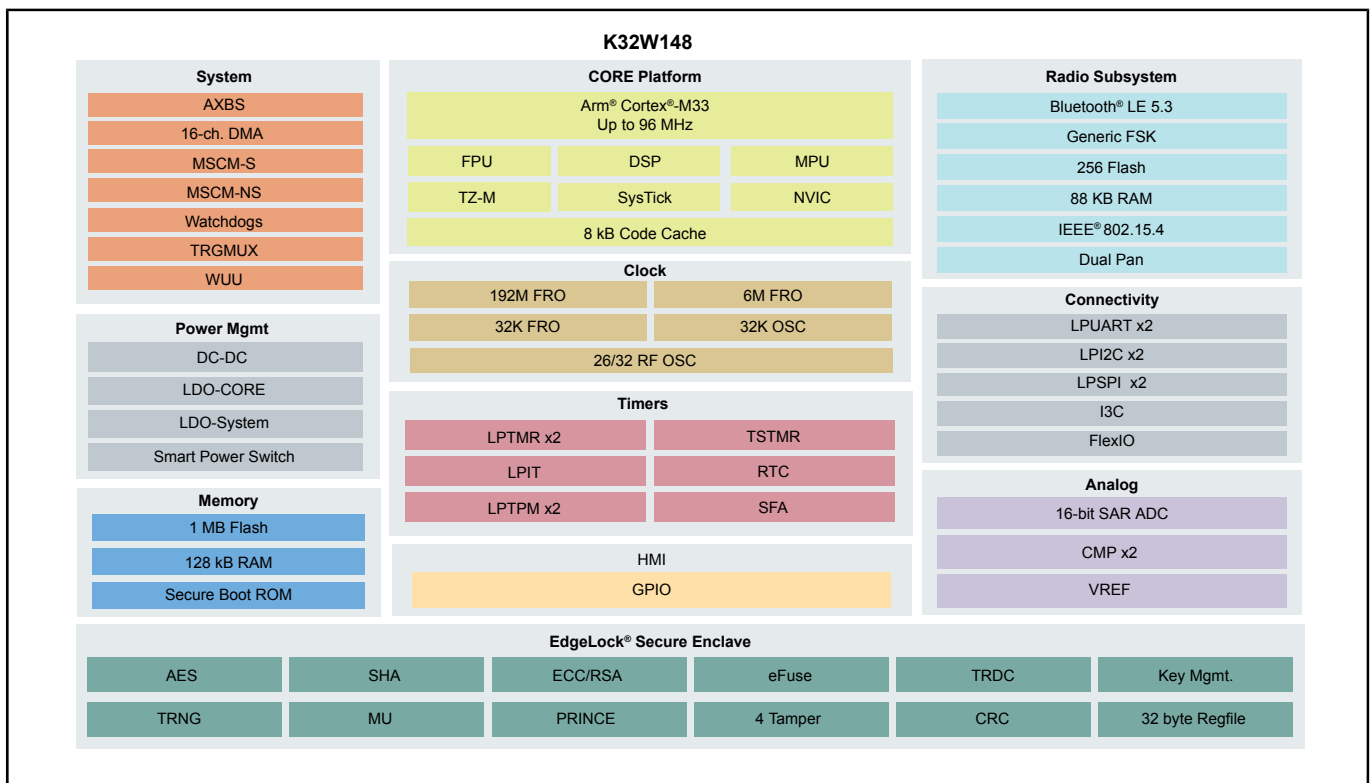

View additional information for [Secure and Ultra-Low-Power MCU for Matter Over Thread™ and Bluetooth® LE 5.3](#).

**Note:** The information on this document is subject to change without notice.

---

**[www.nxp.com](http://www.nxp.com)**

NXP and the NXP logo are trademarks of NXP B.V. All other product or service names are the property of their respective owners. The related technology may be protected by any or all of patents, copyrights, designs and trade secrets. All rights reserved. © 2024 NXP B.V.