



Heating Ventilation and Air Conditioning (HVAC)

Last Updated: Nov 22, 2023

Heating, Ventilation and Air Conditioning (HVAC) systems aim to regulate, heat, cool, ventilate, clean or dehumidify the indoor air quality (IAQ) within the vehicle cabin. HVAC systems consist of sensors and mechanical/electronic switches in the frontend and blower motors, actuators (for fresh air circulation control, air-flow control, and temperature control), and refrigeration units to transfer air to the cabin within the backend to ensure thermal comfort for drivers and passengers.

NXP provides a broad family of Arm® Cortex® -M-based MCUs (S32K) with motor control libraries to cover a wide range of needs in this application space. Additionally, NXP offers motor control-integrated solutions for a cost-effective, small footprint system solution for HVAC applications. The broad portfolio of S12 MagniV® devices combines MCU with SBC functionalities, network connection and motor control specific drivers in a single package and are supported by a library of motor control algorithms.

HVAC Block Diagram

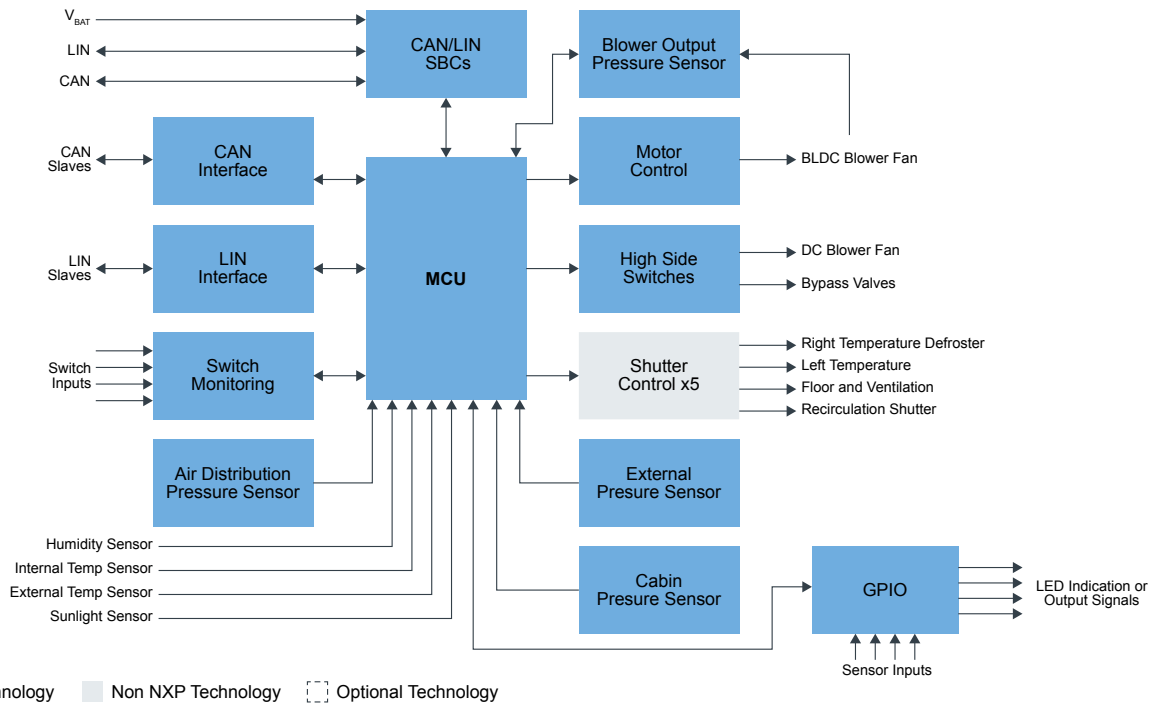

Recommended Products for HVAC

Microcontrollers (MCU)	<ul style="list-style-type: none"> • S32M2: S32M2 Integrated Solution for 12V Motor Control • S32K3: S32K3 Microcontrollers for Automotive General Purpose • S32K1: S32K1 Microcontrollers for Automotive General Purpose
GPIO	<ul style="list-style-type: none"> • PCAL9722: 22-Bit SPI I/O Expander with Agile I/O Features • PCAL9714: 14-Bit SPI I/O Expander with Agile I/O Features
CAN/LIN SBC	<ul style="list-style-type: none"> • FS23: Safety System Basis Chip (SBC) Family with Power Management, CAN and LIN • FS24: Safety Mini CAN FD SBC for Automotive Applications Fit for ASIL-B • FS26: Safety System Basis Chip with Low Power, for ASIL D Systems • TJA1128: LIN Mini System Basis Chip • MC33742: SBC with Enhanced High-Speed CAN Transceiver • MC33904: System Basis Chip Gen2 with High Speed CAN • MC33905: SBC Gen2 with High-Speed CAN and LIN

	<ul style="list-style-type: none"> • MC33910: LIN SBC with 2 x 60 mA High Side Drivers • MC33911: LIN System Basis Chip with DC Motor Predriver • MC33912: LIN SBC with DC Motor Predriver and Current Sense
CAN Interface	<ul style="list-style-type: none"> • TJA144x: Automotive CAN FD Transceiver Family • TJA1044: High-Speed CAN Transceiver with Standby Mode - Mantis Family
LIN Interface	<ul style="list-style-type: none"> • TJA1128: LIN Mini System Basis Chip • TJA1029: LIN 2.2A/SAE J2602 Transceiver with TXD Dominant Timeout • MC33662: LIN 2.1 / SAEJ2602-2, LIN Physical Layer • MM908E624: 8-Bit MCU with Integrated Vreg, HSS, Relay Drivers, LIN
Switch Monitoring	<ul style="list-style-type: none"> • MC33972: MSDI with Suppressed Wakeup • MC33975: MSDI with 32 mA Suppressed Wakeup
Motor Control	<ul style="list-style-type: none"> • S12ZVM: S12ZVM Mixed-Signal MCU for Automotive and Industrial Motor Control Applications • MC33937: 3-Phase Field Effect Transistor Pre-Driver • MC33932: H-Bridge Motor Driver, 5-28 V, 5 A, 11 kHz
High Side Switches	<ul style="list-style-type: none"> • MC33937: 3-Phase Field Effect Transistor Pre-Driver • MC33932: H-Bridge Motor Driver, 5-28 V, 5 A, 11 kHz
Sensors	<ul style="list-style-type: none"> • Sensors: Sensors
Sensors	<ul style="list-style-type: none"> • Sensors: Sensors
Sensors	<ul style="list-style-type: none"> • Sensors: Sensors
Sensors	<ul style="list-style-type: none"> • Sensors: Sensors

View our complete solution for [Heating Ventilation and Air Conditioning \(HVAC\)](#).

Note: The information on this document is subject to change without notice.

www.nxp.com

NXP and the NXP logo are trademarks of NXP B.V. All other product or service names are the property of their respective owners. The related technology may be protected by any or all of patents, copyrights, designs and trade secrets. All rights reserved. © 2024 NXP B.V.